



# KMP Medium Profile Evaporator

**60**  
Hz

## PRODUCT DATA & INSTALLATION

Bulletin K30-KMP-PDI-12  
Part # 1082851

	<b>PRODUCT SUPPORT</b> web: <a href="http://k-rp.com/kmp">k-rp.com/kmp</a> email: <a href="mailto:evaps@k-rp.com">evaps@k-rp.com</a> call: 1-844-893-3222 x520	scan: 
--	---	-----------

Air, Electric, Hot Gas  
& Warm Fluid Defrost

Electrical Power:  
208-230/1/60, 208-230/3/60,  
460/1/60, 460/3/60, 575/1/60, 575/3/60

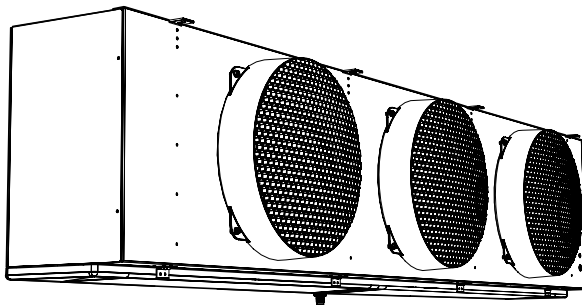

## SMARTSPEED™

FAN MOTOR TECHNOLOGY  
See Page page 19 for details



## CONTENTS

	Page
Nomenclature.....	2
Features & Options.....	2
Capacity Data.....	3
Electrical Data.....	4 - 9
Wiring Diagrams - Models with standard PSC motors .....	10 - 18
Wiring Diagrams - Models with optional EC Motors / <b>SMARTSPEED™</b> .....	19 - 23
Wiring Diagrams - Models with optional Variable Speed EC Motors .....	24 - 26
Dimensional Data/Specifications.....	27 - 28
Shipping Weights.....	29
Factory Installed Distributor Nozzles.....	30
Recommended Expansion Valve Selections.....	31 - 32
Installation Instructions.....	33 - 34
Hot Gas Piping Schematics.....	35 - 36
Glycol Fluid Cooler Data.....	37
Project Information.....	38
Product Support Resources: Service Parts, Troubleshooting, Warranty, etc.....	39
“As Built” Service Parts.....	BACK

# NOMENCLATURE

K MP 3 48 L E - T5 A - T

K = KeepRite

Medium Profile Evaporator

Number of Fans

Nominal Capacity:

x 1000 @ 10°F TD, Btu/H, R404A

Application Range:

M = Medium to High Temp 6 FPI (10°F to 45°F Evap Temp) \*

L = Low Temp 6 FPI (-40°F to 0°F Evap Temp)

V = Low Temp 4 FPI (-40°F to 0°F Evap Temp)

W = Fluid Air Cooler (with water or glycol)

\* except "488M", which is 8 FPI

**Motor:**

C = PSC Motors

T = SmartSpeed ECM

V = Variable Speed EC Motors (Requires a Controller)

**Generation:** A = 1<sup>st</sup>

**Voltage:**

S2 = 208-230/1/60

S4 = 460/1/60

S5 = 575/1/60

T3 = 208-230/3/60

T4 = 460/3/60

T5 = 575/3/60

**Defrost:**

A = Air

E = Electric

T = 3 Pipe Hot Gas w/ Electric Heater Pan

or Warm Fluid w/ Electric Heater Pan for Fluid Air Coolers

H = 3 Pipe Hot Gas w/ Hot Gas Loop Pan (optional)

G = Reverse Cycle w/ Electric Heater Pan

R = Reverse Cycle w/ Hot Gas Loop Pan (optional)

## STANDARD FEATURES

- Compatible with Low GWP Refrigerants
- Totally enclosed high efficiency PSC motors
- High efficiency and high strength fan guard
- Hinged access panels
- Internally enhanced tubing
- Ample electrical and header compartments
- Adjustable Fan Delay on medium temp. Electric Defrost units
- Liquid line solenoid valve wire harness factory installed
- Schrader valve on suction header
- Positive slope, hinged drain pan
- Central drain connections (approximate)
- Universal drain fitting
- Large 3/4" ID (3/4" MPT) drain hole
- Factory installed distributor nozzle

## AVAILABLE OPTIONS

- EC motors with patented SmartSpeed® Technology. See page page 19
- Hot gas loop pan with hot gas defrost models
- 230/460V Variable Speed EC Motors
- Wire fan guard
- Factory installed expansion valve, solenoid valve and room thermostat
- Corrosion protection: alternate fin materials and coatings
- Additional options available, please contact factory

Medium Temperature Models - Capacity @ 6 F.P.I. \*

Medium Temp. Models KMP		118M	122M	228M	236M	245M	355M	368M	480M	488M *	
Number Of Fans		1	1	2	2	2	3	3	4	4	
Capacity BTUH (WATTS)	Evap Temp. 25°F (-4°C)	R407A	17100	20900	26600	34200	42750	52300	64600	76000	83600
		R448A	(5007)	(6118)	(7790)	(9975)	(12540)	(15295)	(18905)	(22230)	(24510)
		R407C	16200	19800	25200	32400	40500	49500	61400	72200	79400
		R404A	(4743)	(5796)	(7380)	(9450)	(11880)	(14490)	(17910)	(21060)	(23220)
		R507	18000	22000	28000	36000	45000	55000	68000	80000	88000
		(5270)	(6440)	(8200)	(10500)	(13200)	(16100)	(19900)	(23400)	(25800)	
	R22	17100	20900	26600	34200	42800	52300	64600	76000	83600	
	(5007)	(6118)	(7790)	(9975)	(12540)	(15295)	(18905)	(22230)	(24510)		
	R134a	16200	19800	25200	32400	40500	49500	61200	72000	79200	
	(4743)	(5796)	(7380)	(9450)	(11880)	(14490)	(17910)	(21060)	(23220)		
Air Flow	CFM (L/S)	3430 (1619)	3240 (1529)	7260 (3426)	6870 (3242)	6480 (3058)	10300 (4861)	9720 (4587)	13000 (6135)	12200 (5758)	
Refrigerant ** Charge R407A	LB. (KG)	4.0 (1.8)	5.3 (2.4)	4.6 (2.1)	7.7 (3.5)	10.0 (4.5)	11.0 (5.0)	15.0 (6.8)	18.0 (8.2)	18.0 (8.2)	

Low Temperature Models - Capacity @ 6 F.P.I. \*

Low Temp. Models KMP		116L	119L	225L	232L	240L	348L	356L	471L	
Number Of Fans		1	1	2	2	2	3	3	4	
Capacity BTUH (WATTS)	Evap Temp. -20°F (-29°C)	R407A	15200	18050	23750	30400	38000	45600	53200	67500
		R448A	(4456)	(5292)	(6954)	(8902)	(11115)	(13395)	(15580)	(19760)
		R407C	14400	17100	22500	28800	36000	43200	50500	64100
		(4221)	(5013)	(6588)	(8433)	(10530)	(12690)	(14760)	(18720)	
		R404A	16000	19000	25000	32000	40000	48000	56000	71000
		(4690)	(5570)	(7320)	(9370)	(11700)	(14100)	(16400)	(20800)	
	R22	15200	18050	23750	30400	38000	45600	53200	67500	
	(4456)	(5292)	(6954)	(8902)	(11115)	(13395)	(15580)	(19760)		
	R134a	14400	17100	22500	28800	36000	43200	50400	63900	
	(4221)	(5013)	(6588)	(8433)	(10530)	(12690)	(14760)	(18720)		
Air Flow	CFM (L/S)	3430 (1619)	3240 (1529)	7260 (3426)	6870 (3242)	6480 (3058)	10300 (4861)	9720 (4587)	13000 (6135)	
Refrigerant ** Charge R407A	LB. (KG)	4.0 (1.8)	5.3 (2.4)	4.6 (2.1)	7.7 (3.5)	10.0 (4.5)	11.0 (5.0)	15.0 (6.8)	18.0 (8.2)	

Low Temperature Models - Capacity @ 4 F.P.I. \*

Low Temp. 4 FPI Models KMP		113V	117V	222V	228V	234V	339V	350V	459V	
Number Of Fans		1	1	2	2	2	3	3	4	
Capacity BTUH (WATTS)	Evap Temp. -20°F (-29°C)	R407A	12350	16150	20900	26600	32300	37100	47500	56100
		R448A	(3610)	(4731)	(6118)	(7790)	(9462)	(10830)	(13965)	(16435)
		R407C	11700	15300	19800	25200	30600	35100	45100	53300
		(3420)	(4482)	(5796)	(7380)	(8964)	(10260)	(13230)	(15570)	
		R404A	13000	17000	22000	28000	34000	39000	50000	59000
		(3800)	(4980)	(6440)	(8200)	(9960)	(11400)	(14700)	(17300)	
	R22	12350	16150	20900	26600	32300	37100	47500	56100	
	(3610)	(4731)	(6118)	(7790)	(9462)	(10830)	(13965)	(16435)		
	R134a	11700	15300	19800	25200	30600	35100	45000	53100	
	(3420)	(4482)	(5796)	(7380)	(8964)	(10260)	(13230)	(15570)		
Air Flow	CFM (L/S)	3640 (1718)	3430 (1619)	7690 (3629)	7280 (3436)	6870 (3242)	10900 (5144)	10300 (4861)	13700 (6466)	
Refrigerant ** Charge R407A	LB. (KG)	4.0 (1.8)	5.3 (2.4)	4.6 (2.1)	7.7 (3.5)	10.0 (4.5)	11.0 (5.0)	15.0 (6.8)	18.0 (8.2)	

Capacities rated using 10°F (5.6°C) TD & 100°F (38°C) liquid temperature.

Capacities at other TD within a range of 8 to 15 °F (4.4 to 8.3°C) are directly proportional to TD, or use formula: Capacity = Rated capacity ÷ 10 x TD.

For capacities at TD outside of range 8 to 15 °F (4.4 to 8.3°C), or liquid temperature lower than 75°F (24°C), consult factory.

Capacities for R448A, R407A and R407C are based on mean temperature. Mean temperature is the average temperature between the saturated suction temperature and the temperature feeding the evaporator. For dew point ratings, consult factory.

For R449A, use R448A data.

\* CAPACITY CORRECTION FACTORS FOR LOW TEMPERATURE UNITS

SATURATED SUCTION TEMPERATURE °F (°C)	0 (-17.8)	-10 (23.3)	-20 (-28.9)	-30 (-34.4)	-40 (-40)
FACTOR	1.06	1.03	1.0	0.92	0.85

\*\* REFRIGERANT CHARGE CONVERSION FACTORS

R448A	R407C	R404A	R507	R22	R134a
0.96	0.99	0.92	0.93	1.02	1.03

NO CORRECTION FACTOR REQUIRED FOR MEDIUM TEMP. UNITS

# ELECTRICAL DATA - 208-230/1/60

## AIR DEFROST & HOT GAS DEFROST WITH HOT GAS LOOP PAN MODELS

MODEL KMP	FPI	FAN MOTORS															
		QTY	STANDARD PSC MOTORS					OPTIONAL SMARTSPEED <sup>™</sup> EC MOTORS					OPTIONAL VARIABLE SPEED EC MOTORS				
			HP	FLA TOTAL	WATTS	MCA (A)	MAX. FUSE (AMPS)	HP	FLA TOTAL	WATTS	MCA (A)	MAX. FUSE (AMPS)	HP	FLA TOTAL	WATTS	MCA (A)	MAX. FUSE (AMPS)
118M#-S2A	6	1	1/3	1.7	320	2.1	15	1/3	2.6	230	3.3	15	1/4	3.3	230	3.3	15
122M#-S2A		1	1/3	1.7	320	2.1	15	1/3	2.6	230	3.3	15	1/4	3.3	230	3.3	15
228M#-S2A		2	1/3	3.4	640	3.8	15	1/3	5.2	460	5.9	15	1/4	5.9	460	5.9	15
236M#-S2A		2	1/3	3.4	640	3.8	15	1/3	5.2	460	5.9	15	1/4	5.9	460	5.9	15
245M#-S2A		2	1/3	3.4	640	3.8	15	1/3	5.2	460	5.9	15	1/4	5.9	460	5.9	15
355M#-S2A		3	1/3	5.1	960	5.5	15	1/3	7.8	690	8.5	15	1/4	8.5	690	8.5	15
368M#-S2A		3	1/3	5.1	960	5.5	15	1/3	7.8	690	8.5	15	1/4	8.5	690	8.5	15
480M#-S2A		4	1/3	6.8	1280	7.2	15	1/3	10.4	980	11.1	15	1/4	11.1	920	11.1	15
488M#-S2A	8	4	1/3	6.8	1280	7.2	15	1/3	10.4	980	11.1	15	1/4	11.1	920	11.1	15
116L†-S2A		1	1/3	1.7	320	2.1	15	1/3	2.6	230	3.3	15	1/4	3.3	230	3.3	15
119L†-S2A	6	1	1/3	1.7	320	2.1	15	1/3	2.6	230	3.3	15	1/4	3.3	230	3.3	15
225L#-S2A		2	1/3	3.4	640	3.8	15	1/3	5.2	460	5.9	15	1/4	5.9	460	5.9	15
232L#-S2A		2	1/3	3.4	640	3.8	15	1/3	5.2	460	5.9	15	1/4	5.9	460	5.9	15
240L#-S2A		2	1/3	3.4	640	3.8	15	1/3	5.2	460	5.9	15	1/4	5.9	460	5.9	15
348L#-S2A		3	1/3	5.1	960	5.5	15	1/3	7.8	690	8.5	15	1/4	8.5	690	8.5	15
356L#-S2A		3	1/3	5.1	960	5.5	15	1/3	7.8	690	8.5	15	1/4	8.5	690	8.5	15
471L#-S2A		4	1/3	6.8	1280	7.2	15	1/3	10.4	980	11.1	15	1/4	11.1	920	11.1	15
113V†-S2A		4	1	1/3	1.7	320	2.1	15	1/3	2.6	230	3.3	15	1/4	3.3	230	3.3
117V†-S2A	1		1/3	1.7	320	2.1	15	1/3	2.6	230	3.3	15	1/4	3.3	230	3.3	15
222V#-S2A	2		1/3	3.4	640	3.8	15	1/3	5.2	460	5.9	15	1/4	5.9	460	5.9	15
228V#-S2A	2		1/3	3.4	640	3.8	15	1/3	5.2	460	5.9	15	1/4	5.9	460	5.9	15
234V#-S2A	2		1/3	3.4	640	3.8	15	1/3	5.2	460	5.9	15	1/4	5.9	460	5.9	15
339V#-S2A	3		1/3	5.1	960	5.5	15	1/3	7.8	690	8.5	15	1/4	8.5	690	8.5	15
350V#-S2A	3		1/3	5.1	960	5.5	15	1/3	7.8	690	8.5	15	1/4	8.5	690	8.5	15
459V#-S2A	4		1/3	6.8	1280	7.2	15	1/3	10.4	920	11.1	15	1/4	11.1	920	11.1	15

# = A, H or R. Refer to Nomenclature for details    † = H or R. Refer to Nomenclature for details

# ELECTRICAL DATA - 460/1/60

## AIR DEFROST & HOT GAS DEFROST WITH HOT GAS LOOP PAN MODELS

MODEL KMP	FPI	FAN MOTORS										
		QTY	STANDARD PSC MOTORS					OPTIONAL VARIABLE SPEED EC MOTORS				
			HP	FLA TOTAL	WATTS	MCA (A)	MAX. FUSE (AMPS)	HP	FLA TOTAL	WATTS	MCA (A)	MAX. FUSE (AMPS)
118M#-S4A	6	1	1/3	0.9	330	1.1	15	1/3	1	230	1.25	15
122M#-S4A		1	1/3	0.9	330	1.1	15	1/3	1	230	1.25	15
228M#-S4A		2	1/3	1.8	660	2.0	15	1/3	2	460	2.25	15
236M#-S4A		2	1/3	1.8	660	2.0	15	1/3	2	460	2.25	15
245M#-S4A		2	1/3	1.8	660	2.0	15	1/3	2	460	2.25	15
355M#-S4A		3	1/3	2.7	990	2.9	15	1/3	3	690	3.25	15
368M#-S4A		3	1/3	2.7	990	2.9	15	1/3	3	690	3.25	15
480M#-S4A		4	1/3	3.6	1320	3.8	15	1/3	4	920	4.25	15
488M#-S4A	8	4	1/3	3.6	1320	3.8	15	1/3	4	920	4.25	15
116L†-S4A		1	1/3	0.9	330	1.1	15	1/3	1	230	1.25	15
119L†-S4A	6	1	1/3	0.9	330	1.1	15	1/3	1	230	1.25	15
225L#-S4A		2	1/3	1.8	660	2.0	15	1/3	2	460	2.25	15
232L#-S4A		2	1/3	1.8	660	2.0	15	1/3	2	460	2.25	15
240L#-S4A		2	1/3	1.8	660	2.0	15	1/3	2	460	2.25	15
348L#-S4A		3	1/3	2.7	990	2.9	15	1/3	3	690	3.25	15
356L#-S4A		3	1/3	2.7	990	2.9	15	1/3	3	690	3.25	15
471L#-S4A		4	1/3	3.6	1320	3.8	15	1/3	4	920	4.25	15
113V†-S4A		4	1	1/3	0.9	330	1.1	15	1/3	1	230	1.25
117V†-S4A	1		1/3	0.9	330	1.1	15	1/3	1	230	1.25	15
222V#-S4A	2		1/3	1.8	660	2.0	15	1/3	2	460	2.25	15
228V#-S4A	2		1/3	1.8	660	2.0	15	1/3	2	460	2.25	15
234V#-S4A	2		1/3	1.8	660	2.0	15	1/3	2	460	2.25	15
339V#-S4A	3		1/3	2.7	990	2.9	15	1/3	3	690	3.25	15
350V#-S4A	3		1/3	2.7	990	2.9	15	1/3	3	690	3.25	15
459V#-S4A	4		1/3	3.6	1320	3.8	15	1/3	4	920	4.25	15

# = A, H or R. Refer to Nomenclature for details    † = H or R. Refer to Nomenclature for details

**ELECTRICAL DATA - 575/1/60  
AIR DEFROST & HOT GAS DEFROST  
WITH HOT GAS LOOP PAN MODELS**

MODEL KMP	FPI	FAN MOTORS					
		QUANTITY	HP	FLA TOTAL	WATTS	MCA (A)	MAX. FUSE (AMPS)
118M#-S5A	6	1	1/3	0.7	337	0.9	15
122M#-S5A		1	1/3	0.7	337	0.9	15
228M#-S5A		2	1/3	1.4	674	1.6	15
236M#-S5A		2	1/3	1.4	674	1.6	15
245M#-S5A		2	1/3	1.4	674	1.6	15
355M#-S5A		3	1/3	2.1	1011	2.3	15
368M#-S5A		3	1/3	2.1	1011	2.3	15
480M#-S5A		4	1/3	2.8	1348	3.0	15
488M#-S5A		8	4	1/3	2.8	1348	3.0
116L†-S5A	6	1	1/3	0.7	337	0.9	15
119L†-S5A		1	1/3	0.7	337	0.9	15
225L#-S5A		2	1/3	1.4	674	1.6	15
232L#-S5A		2	1/3	1.4	674	1.6	15
240L#-S5A		2	1/3	1.4	674	1.6	15
348L#-S5A		3	1/3	2.1	1011	2.3	15
356L#-S5A		3	1/3	2.1	1011	2.3	15
471L#-S5A		4	1/3	2.8	1348	3.0	15
113V†-S5A		4	1	1/3	0.7	337	0.9
117V†-S5A	1		1/3	0.7	337	0.9	15
222V#-S5A	2		1/3	1.4	674	1.6	15
228V#-S5A	2		1/3	1.4	674	1.6	15
234V#-S5A	2		1/3	1.4	674	1.6	15
339V#-S5A	3		1/3	2.1	1011	2.3	15
350V#-S5A	3		1/3	2.1	1011	2.3	15
459V#-S5A	4		1/3	2.8	1348	3.0	15

# = A, H or R. Refer to Nomenclature for details

† = H or R. Refer to Nomenclature for details

ELECTRIC DEFROST MODELS

MODEL KMP	FPI	FAN MOTORS															DEFROST HEATERS				
		QTY	STANDARD PSC MOTORS					OPTIONAL SMART <sup>®</sup> SPEED <sup>™</sup> EC MOTORS					OPTIONAL VARIABLE SPEED EC MOTORS					TOTAL WATTS	TOTAL AMPS	MCA (A)	MAX. FUSE (AMPS)
			HP	FLA TOTAL	WATTS	MCA (A)	MAX. FUSE (AMPS)	HP	FLA TOTAL	WATTS	MCA (A)	MAX. FUSE (AMPS)	HP	FLA TOTAL	WATTS	MCA (A)	MAX. FUSE (AMPS)				
118ME-*A	6	1	1/3	1.7	320	2.1	15	1/3	2.6	230	3.3	15	1/4	2.6	230	3.3	15	3330	14.5	18	20
122ME-*A		1	1/3	1.7	320	2.1	15	1/3	2.6	230	3.3	15	1/4	2.6	230	3.3	15	3330	14.5	18	20
228ME-*A		2	1/3	3.4	640	3.8	15	1/3	5.2	460	5.9	15	1/4	5.2	460	5.9	15	6190	26.9	34	35
236ME-*A		2	1/3	3.4	640	3.8	15	1/3	5.2	460	5.9	15	1/4	5.2	460	5.9	15	6190	26.9	34	35
245ME-*A		2	1/3	3.4	640	3.8	15	1/3	5.2	460	5.9	15	1/4	5.2	460	5.9	15	6190	26.9	34	35
355ME-*A		3	1/3	5.1	960	5.5	15	1/3	7.8	690	8.5	15	1/4	7.8	690	8.5	15	9040	39.3	49	50
368ME-*A		3	1/3	5.1	960	5.5	15	1/3	7.8	690	8.5	15	1/4	7.8	690	8.5	15	9040	39.3	49	50
480ME-*A		4	1/3	6.8	1280	7.2	15	1/3	10.4	980	11.1	15	1/4	10.4	920	11.1	15	10600	46.1	58	60
488ME-*A	8	4	1/3	6.8	1280	7.2	15	1/3	10.4	980	11.1	15	1/4	10.4	920	11.1	15	10600	46.1	58	60
116LE-*A		1	1/3	1.7	320	2.1	15	1/3	2.6	230	3.3	15	1/4	2.6	230	3.3	15	3330	14.5	18	20
119LE-*A		1	1/3	1.7	320	2.1	15	1/3	2.6	230	3.3	15	1/4	2.6	230	3.3	15	3330	14.5	18	20
225LE-*A		2	1/3	3.4	640	3.8	15	1/3	5.2	460	5.9	15	1/4	5.2	460	5.9	15	6190	26.9	34	35
232LE-*A		2	1/3	3.4	640	3.8	15	1/3	5.2	460	5.9	15	1/4	5.2	460	5.9	15	6190	26.9	34	35
240LE-*A		2	1/3	3.4	640	3.8	15	1/3	5.2	460	5.9	15	1/4	5.2	460	5.9	15	6190	26.9	34	35
348LE-*A		3	1/3	5.1	960	5.5	15	1/3	7.8	690	8.5	15	1/4	7.8	690	8.5	15	9040	39.3	49	50
356LE-*A		3	1/3	5.1	960	5.5	15	1/3	7.8	690	8.5	15	1/4	7.8	690	8.5	15	9040	39.3	49	50
471LE-*A	4	1/3	6.8	1280	7.2	15	1/3	10.4	980	11.1	15	1/4	10.4	920	11.1	15	10600	46.1	58	60	
113VE-*A	4	1	1/3	1.7	320	2.1	15	1/3	2.6	230	3.3	15	1/4	2.6	230	3.3	15	3330	14.5	18	20
117VE-*A		1	1/3	1.7	320	2.1	15	1/3	2.6	230	3.3	15	1/4	2.6	230	3.3	15	3330	14.5	18	20
222VE-*A		2	1/3	3.4	640	3.8	15	1/3	5.2	460	5.9	15	1/4	5.2	460	5.9	15	6190	26.9	34	35
228VE-*A		2	1/3	3.4	640	3.8	15	1/3	5.2	460	5.9	15	1/4	5.2	460	5.9	15	6190	26.9	34	35
234VE-*A		2	1/3	3.4	640	3.8	15	1/3	5.2	460	5.9	15	1/4	5.2	460	5.9	15	6190	26.9	34	35
339VE-*A		3	1/3	5.1	960	5.5	15	1/3	7.8	690	8.5	15	1/4	7.8	690	8.5	15	9040	39.3	49	50
350VE-*A		3	1/3	5.1	960	5.5	15	1/3	7.8	690	8.5	15	1/4	7.8	690	8.5	15	9040	39.3	49	50
459VE-*A		4	1/3	6.8	1280	7.2	15	1/3	10.4	920	11.1	15	1/4	10.4	920	11.1	15	10600	46.1	58	60

\* = S2 or T3. Refer to Nomenclature for details

ELECTRICAL DATA - 208-230/3/60

ELECTRIC DEFROST MODELS

MODEL KMP	FPI	FAN MOTORS															DEFROST HEATERS				
		QTY	STANDARD PSC MOTORS					OPTIONAL SMART <sup>®</sup> SPEED <sup>™</sup> EC MOTORS					OPTIONAL VARIABLE SPEED EC MOTORS					TOTAL WATTS	TOTAL AMPS	MCA (A)	MAX. FUSE (AMPS)
			HP	FLA TOTAL	WATTS	MCA (A)	MAX. FUSE (AMPS)	HP	FLA TOTAL	WATTS	MCA (A)	MAX. FUSE (AMPS)	HP	FLA TOTAL	WATTS	MCA (A)	MAX. FUSE (AMPS)				
118ME-*A	6	1	1/3	1.7	320	2.1	15	1/3	2.6	230	3.3	15	1/4	2.6	230	3.3	15	3330	9.9	12	15
122ME-*A		1	1/3	1.7	320	2.1	15	1/3	2.6	230	3.3	15	1/4	2.6	230	3.3	15	3330	9.9	12	15
228ME-*A		2	1/3	3.4	640	3.8	15	1/3	5.2	460	5.9	15	1/4	5.2	460	5.9	15	6190	18.3	23	25
236ME-*A		2	1/3	3.4	640	3.8	15	1/3	5.2	460	5.9	15	1/4	5.2	460	5.9	15	6190	18.3	23	25
245ME-*A		2	1/3	3.4	640	3.8	15	1/3	5.2	460	5.9	15	1/4	5.2	460	5.9	15	6190	18.3	23	25
355ME-*A		3	1/3	5.1	960	5.5	15	1/3	7.8	690	8.5	15	1/4	7.8	690	8.5	15	9040	26.7	33	35
368ME-*A		3	1/3	5.1	960	5.5	15	1/3	7.8	690	8.5	15	1/4	7.8	690	8.5	15	9040	26.7	33	35
480ME-*A		4	1/3	6.8	1280	7.2	15	1/3	10.4	920	11.1	15	1/4	10.4	920	11.1	15	10600	31.2	39	40
488ME-*A	8	4	1/3	6.8	1280	7.2	15	1/3	10.4	920	11.1	15	1/4	10.4	920	11.1	15	10600	31.2	39	40
116LE-*A		1	1/3	1.7	320	2.1	15	1/3	2.6	230	3.3	15	1/4	2.6	230	3.3	15	3330	9.9	12	15
119LE-*A		1	1/3	1.7	320	2.1	15	1/3	2.6	230	3.3	15	1/4	2.6	230	3.3	15	3330	9.9	12	15
225LE-*A		2	1/3	3.4	640	3.8	15	1/3	5.2	460	5.9	15	1/4	5.2	460	5.9	15	6190	18.3	23	25
232LE-*A		2	1/3	3.4	640	3.8	15	1/3	5.2	460	5.9	15	1/4	5.2	460	5.9	15	6190	18.3	23	25
240LE-*A		2	1/3	3.4	640	3.8	15	1/3	5.2	460	5.9	15	1/4	5.2	460	5.9	15	6190	18.3	23	25
348LE-*A		3	1/3	5.1	960	5.5	15	1/3	7.8	690	8.5	15	1/4	7.8	690	8.5	15	9040	26.7	33	35
356LE-*A		3	1/3	5.1	960	5.5	15	1/3	7.8	690	8.5	15	1/4	7.8	690	8.5	15	9040	26.7	33	35
471LE-*A	4	1/3	6.8	1280	7.2	15	1/3	10.4	920	11.1	15	1/4	10.4	920	11.1	15	10600	31.2	39	40	
113VE-*A	4	1	1/3	1.7	320	2.1	15	1/3	2.6	230	3.3	15	1/4	2.6	230	3.3	15	3330	9.9	12	15
117VE-*A		1	1/3	1.7	320	2.1	15	1/3	2.6	230	3.3	15	1/4	2.6	230	3.3	15	3330	9.9	12	15
222VE-*A		2	1/3	3.4	640	3.8	15	1/3	5.2	460	5.9	15	1/4	5.2	460	5.9	15	6190	18.3	23	25
228VE-*A		2	1/3	3.4	640	3.8	15	1/3	5.2	460	5.9	15	1/4	5.2	460	5.9	15	6190	18.3	23	25
234VE-*A		2	1/3	3.4	640	3.8	15	1/3	5.2	460	5.9	15	1/4	5.2	460	5.9	15	6190	18.3	23	25
339VE-*A		3	1/3	5.1	960	5.5	15	1/3	7.8	690	8.5	15	1/4	7.8	690	8.5	15	9040	26.7	33	35
350VE-*A		3	1/3	5.1	960	5.5	15	1/3	7.8	690	8.5	15	1/4	7.8	690	8.5	15	9040	26.7	33	35
459VE-*A		4	1/3	6.8	1280	7.2	15	1/3	10.4	920	11.1	15	1/4	10.4	920	11.1	15	10600	31.2	39	40

\* = S2 or T3. Refer to Nomenclature for details



**ELECTRIC DEFROST MODELS**

MODEL KMP	FPI	FAN MOTORS										DEFROST HEATERS							
		QTY	STANDARD PSC FAN MOTORS					OPTIONAL VARIABLE SPEED EC MOTORS					TOTAL WATTS	460/1/60			460/3/60		
			HP	FLA TOTAL	WATTS	MCA (A)	MAX. FUUSE (AMPS)	HP	FLA TOTAL	WATTS	MCA (A)	MAX. FUUSE (AMPS)		TOTAL AMPS	MCA (A)	MAX. FUUSE (AMPS)	TOTAL AMPS	MCA (A)	MAX. FUUSE (AMPS)
118ME-*A	6	1	1/3	0.9	330	1.1	15	1/3	1	230	1.25	15	3330	7.2	9.0	15	5.0	6.2	15
122ME-*A		1	1/3	0.9	330	1.1	15	1/3	1	230	1.25	15	3330	7.2	9.0	15	5.0	6.2	15
228ME-*A		2	1/3	1.8	660	2.0	15	1/3	2	460	2.25	15	6190	13.5	17	20	9.2	11	15
236ME-*A		2	1/3	1.8	660	2.0	15	1/3	2	460	2.25	15	6190	13.5	17	20	9.2	11	15
245ME-*A		2	1/3	1.8	660	2.0	15	1/3	2	460	2.25	15	6190	13.5	17	20	9.2	11	15
355ME-*A		3	1/3	2.7	990	2.9	15	1/3	3	690	3.25	15	9040	19.7	25	25	13.4	17	20
368ME-*A		3	1/3	2.7	990	2.9	15	1/3	3	690	3.25	15	9040	19.7	25	25	13.4	17	20
480ME-*A		4	1/3	3.6	1320	3.8	15	1/3	4	920	4.25	15	10600	23.0	29	30	15.6	19	20
488ME-*A	4	1/3	3.6	1320	3.8	15	1/3	4	920	4.25	15	10600	23.0	29	30	15.6	19	20	
116LE-*A	6	1	1/3	0.9	330	1.1	15	1/3	1	230	1.25	15	3330	7.2	9.0	15	5.0	6.2	15
119LE-*A		1	1/3	0.9	330	1.1	15	1/3	1	230	1.25	15	3330	7.2	9.0	15	5.0	6.2	15
225LE-*A		2	1/3	1.8	660	2.0	15	1/3	2	460	2.25	15	6190	13.5	17	20	9.2	11	15
232LE-*A		2	1/3	1.8	660	2.0	15	1/3	2	460	2.25	15	6190	13.5	17	20	9.2	11	15
240LE-*A		2	1/3	1.8	660	2.0	15	1/3	2	460	2.25	15	6190	13.5	17	20	9.2	11	15
348LE-*A		3	1/3	2.7	990	2.9	15	1/3	3	690	3.25	15	9040	19.7	25	25	13.4	17	20
356LE-*A		3	1/3	2.7	990	2.9	15	1/3	3	690	3.25	15	9040	19.7	25	25	13.4	17	20
471LE-*A		4	1/3	3.6	1320	3.8	15	1/3	4	920	4.25	15	10600	23.0	29	30	15.6	19	20
113VE-*A	4	1	1/3	0.9	330	1.1	15	1/3	1	230	1.25	15	3330	7.2	9.0	15	5.0	6.2	15
117VE-*A		1	1/3	0.9	330	1.1	15	1/3	1	230	1.25	15	3330	7.2	9.0	15	5.0	6.2	15
222VE-*A		2	1/3	1.8	660	2.0	15	1/3	2	460	2.25	15	6190	13.5	17	20	9.2	11	15
228VE-*A		2	1/3	1.8	660	2.0	15	1/3	2	460	2.25	15	6190	13.5	17	20	9.2	11	15
234VE-*A		2	1/3	1.8	660	2.0	15	1/3	2	460	2.25	15	6190	13.5	17	20	9.2	11	15
339VE-*A		3	1/3	2.7	990	2.9	15	1/3	3	690	3.25	15	9040	19.7	25	25	13.4	17	20
350VE-*A		3	1/3	2.7	990	2.9	15	1/3	3	690	3.25	15	9040	19.7	25	25	13.4	17	20
459VE-*A		4	1/3	3.6	1320	3.8	15	1/3	4	920	4.25	15	10600	23.0	29	30	15.6	19	20

\* = S4 or T4. Refer to Nomenclature for details

**ELECTRICAL DATA - 575/1/60 & 575/3/60**

**ELECTRIC DEFROST MODELS**

MODEL KMP	FPI	FAN MOTORS							DEFROST HEATERS					
		QTY.	HP	FLA TOTAL	WATTS	MCA (A)	MAX. FUUSE (AMPS)	TOTAL WATTS	575/1/60			575/3/60		
									TOTAL AMPS	MCA (A)	MAX. FUUSE (AMPS)	TOTAL AMPS	MCA (A)	MAX. FUUSE (AMPS)
118ME-*A	6	1	1/3	0.7	337	0.9	15	3330	5.8	7.2	15	4.0	5.0	15
122ME-*A		1	1/3	0.7	337	0.9	15	3330	5.8	7.2	15	4.0	5.0	15
228ME-*A		2	1/3	1.4	674	1.6	15	6190	10.8	13	15	7.3	9.2	15
236ME-*A		2	1/3	1.4	674	1.6	15	6190	10.8	13	15	7.3	9.2	15
245ME-*A		2	1/3	1.4	674	1.6	15	6190	10.8	13	15	7.3	9.2	15
355ME-*A		3	1/3	2.1	1011	2.3	15	9040	15.7	20	20	10.7	13	15
368ME-*A		3	1/3	2.1	1011	2.3	15	9040	15.7	20	20	10.7	13	15
480ME-*A		4	1/3	2.8	1348	3.0	15	10600	18.4	23	25	12.5	16	20
488ME-*A	4	1/3	2.8	1348	3.0	15	10600	18.4	23	25	12.5	16	20	
116LE-*A	6	1	1/3	0.7	337	0.9	15	3330	5.8	7.2	15	4.0	5.0	15
119LE-*A		1	1/3	0.7	337	0.9	15	3330	5.8	7.2	15	4.0	5.0	15
225LE-*A		2	1/3	1.4	674	1.6	15	6190	10.8	13	15	7.3	9.2	15
232LE-*A		2	1/3	1.4	674	1.6	15	6190	10.8	13	15	7.3	9.2	15
240LE-*A		2	1/3	1.4	674	1.6	15	6190	10.8	13	15	7.3	9.2	15
348LE-*A		3	1/3	2.1	1011	2.3	15	9040	15.7	20	20	10.7	13	15
356LE-*A		3	1/3	2.1	1011	2.3	15	9040	15.7	20	20	10.7	13	15
471LE-*A		4	1/3	2.8	1348	3.0	15	10600	18.4	23	25	12.5	16	20
113VE-*A	4	1	1/3	0.7	337	0.9	15	3330	5.8	7.2	15	4.0	5.0	15
117VE-*A		1	1/3	0.7	337	0.9	15	3330	5.8	7.2	15	4.0	5.0	15
222VE-*A		2	1/3	1.4	674	1.6	15	6190	10.8	13	15	7.3	9.2	15
228VE-*A		2	1/3	1.4	674	1.6	15	6190	10.8	13	15	7.3	9.2	15
234VE-*A		2	1/3	1.4	674	1.6	15	6190	10.8	13	15	7.3	9.2	15
339VE-*A		3	1/3	2.1	1011	2.3	15	9040	15.7	20	20	10.7	13	15
350VE-*A		3	1/3	2.1	1011	2.3	15	9040	15.7	20	20	10.7	13	15
459VE-*A		4	1/3	2.8	1348	3.0	15	10600	18.4	23	25	12.5	16	20

\* = S5 or T5. Refer to Nomenclature for details

**ELECTRICAL DATA - 208-230/1/60  
HOT GAS DEFROST  
WITH DRAIN PAN HEATER MODELS**

MODEL KMP	FPI	FAN MOTORS										DRAIN PAN HEATERS				
		QTY.	STANDARD PSC MOTORS					OPTIONAL VARIABLE SPEED EC MOTORS					TOTAL WATTS	TOTAL AMPS	MCA (A)	MAX. FUSE (AMPS)
			HP	FLA TOTAL	WATTS	MCA (A)	MAX. FUSE (AMPS)	HP	FLA TOTAL	WATTS	MCA (A)	MAX. FUSE (AMPS)				
118M^S2A	6	1	1/3	1.7	320	2.1	15	1/4	2.6	230	3.3	15	534	2.3	2.9	15
122M^S2A		1	1/3	1.7	320	2.1	15	1/4	2.6	230	3.3	15	534	2.3	2.9	15
228M^S2A		2	1/3	3.4	640	3.8	15	1/4	5.2	460	5.9	15	887	3.9	4.8	15
236M^S2A		2	1/3	3.4	640	3.8	15	1/4	5.2	460	5.9	15	887	3.9	4.8	15
245M^S2A		2	1/3	3.4	640	3.8	15	1/4	5.2	460	5.9	15	887	3.9	4.8	15
355M^S2A		3	1/3	5.1	960	5.5	15	1/4	7.8	690	8.5	15	1240	5.4	6.7	15
368M^S2A		3	1/3	5.1	960	5.5	15	1/4	7.8	690	8.5	15	1240	5.4	6.7	15
480M^S2A		4	1/3	6.8	1280	7.2	15	1/4	10.4	920	11.1	15	1430	6.0	7.8	15
488M^S2A	8	4	1/3	6.8	1280	7.2	15	1/4	10.4	920	11.1	15	1430	6.0	7.8	15
116L^S2A	6	1	1/3	1.7	320	2.1	15	1/4	2.6	230	3.3	15	534	2.3	2.9	15
119L^S2A		1	1/3	1.7	320	2.1	15	1/4	2.6	230	3.3	15	534	2.3	2.9	15
225L^S2A		2	1/3	3.4	640	3.8	15	1/4	5.2	460	5.9	15	887	3.9	4.8	15
232L^S2A		2	1/3	3.4	640	3.8	15	1/4	5.2	460	5.9	15	887	3.9	4.8	15
240L^S2A		2	1/3	3.4	640	3.8	15	1/4	5.2	460	5.9	15	887	3.9	4.8	15
348L^S2A		3	1/3	5.1	960	5.5	15	1/4	7.8	690	8.5	15	1240	5.4	6.7	15
356L^S2A		3	1/3	5.1	960	5.5	15	1/4	7.8	690	8.5	15	1240	5.4	6.7	15
471L^S2A		4	1/3	6.8	1280	7.2	15	1/4	10.4	920	11.1	15	1430	6.2	7.8	15
113V^S2A	4	1	1/3	1.7	320	2.1	15	1/4	2.6	230	3.3	15	534	2.3	2.9	15
117V^S2A		1	1/3	1.7	320	2.1	15	1/4	2.6	230	3.3	15	534	2.3	2.9	15
222V^S2A		2	1/3	3.4	640	3.8	15	1/4	5.2	460	5.9	15	887	3.9	4.8	15
228V^S2A		2	1/3	3.4	640	3.8	15	1/4	5.2	460	5.9	15	887	3.9	4.8	15
234V^S2A		2	1/3	3.4	640	3.8	15	1/4	5.2	460	5.9	15	887	3.9	4.8	15
339V^S2A		3	1/3	5.1	960	5.5	15	1/4	7.8	690	8.5	15	1240	5.4	6.7	15
350V^S2A		3	1/3	5.1	960	5.5	15	1/4	7.8	690	8.5	15	1240	5.4	6.7	15
459V^S2A		4	1/3	6.8	1280	7.2	15	1/4	10.4	920	11.1	15	1430	6.2	7.8	15

^ = T or G. Refer to Nomenclature for details

**ELECTRICAL DATA - 460/1/60  
HOT GAS DEFROST  
WITH DRAIN PAN HEATER MODELS**

MODEL KMP	FPI	FAN MOTORS										DRAIN PAN HEATERS				
		QTY.	STANDARD PSC MOTORS					OPTIONAL VARIABLE SPEED EC MOTORS					TOTAL WATTS	TOTAL AMPS	MCA (A)	MAX. FUSE (AMPS)
			HP	FLA TOTAL	WATTS	MCA (A)	MAX. FUSE (AMPS)	HP	FLA TOTAL	WATTS	MCA (A)	MAX. FUSE (AMPS)				
118M^S4A	6	1	1/3	0.9	330	1.1	15	1/3	1	230	1.25	15	534	1.2	1.5	15
122M^S4A		1	1/3	0.9	330	1.1	15	1/3	1	230	1.25	15	534	1.2	1.5	15
228M^S4A		2	1/3	1.8	660	2.0	15	1/3	2	460	2.25	15	887	1.9	2.4	15
236M^S4A		2	1/3	1.8	660	2.0	15	1/3	2	460	2.25	15	887	1.9	2.4	15
245M^S4A		2	1/3	1.8	660	2.0	15	1/3	2	460	2.25	15	887	1.9	2.4	15
355M^S4A		3	1/3	2.7	990	2.9	15	1/3	3	690	3.25	15	1240	2.7	3.4	15
368M^S4A		3	1/3	2.7	990	2.9	15	1/3	3	690	3.25	15	1240	2.7	3.4	15
480M^S4A		4	1/3	3.6	1320	3.8	15	1/3	4	920	4.25	15	1430	3.1	3.9	15
488M^S4A	8	4	1/3	3.6	1320	3.8	15	1/3	4	920	4.25	15	1430	3.1	3.9	15
116L^S4A	6	1	1/3	0.9	330	1.1	15	1/3	1	230	1.25	15	534	1.2	1.5	15
119L^S4A		1	1/3	0.9	330	1.1	15	1/3	1	230	1.25	15	534	1.2	1.5	15
225L^S4A		2	1/3	1.8	660	2.0	15	1/3	2	460	2.25	15	887	1.9	2.4	15
232L^S4A		2	1/3	1.8	660	2.0	15	1/3	2	460	2.25	15	887	1.9	2.4	15
240L^S4A		2	1/3	1.8	660	2.0	15	1/3	2	460	2.25	15	887	1.9	2.4	15
348L^S4A		3	1/3	2.7	990	2.9	15	1/3	3	690	3.25	15	1240	2.7	3.4	15
356L^S4A		3	1/3	2.7	990	2.9	15	1/3	3	690	3.25	15	1240	2.7	3.4	15
471L^S4A		4	1/3	3.6	1320	3.8	15	1/3	4	920	4.25	15	1430	3.1	3.9	15
113V^S4A	4	1	1/3	0.9	330	1.1	15	1/3	1	230	1.25	15	534	1.2	1.5	15
117V^S4A		1	1/3	0.9	330	1.1	15	1/3	1	230	1.25	15	534	1.2	1.5	15
222V^S4A		2	1/3	1.8	660	2.0	15	1/3	2	460	2.25	15	887	1.9	2.4	15
228V^S4A		2	1/3	1.8	660	2.0	15	1/3	2	460	2.25	15	887	1.9	2.4	15
234V^S4A		2	1/3	1.8	660	2.0	15	1/3	2	460	2.25	15	887	1.9	2.4	15
339V^S4A		3	1/3	2.7	990	2.9	15	1/3	3	690	3.25	15	1240	2.7	3.4	15
350V^S4A		3	1/3	2.7	990	2.9	15	1/3	3	690	3.25	15	1240	2.7	3.4	15
459V^S4A		4	1/3	3.6	1320	3.8	15	1/3	4	920	4.25	15	1430	3.1	3.9	15

^ = T or G. Refer to Nomenclature for details



**ELECTRICAL DATA - 575/1/60  
HOT GAS DEFROST  
WITH DRAIN PAN HEATER MODELS**

MODEL KMP	FPI	FAN MOTORS						DRAIN PAN HEATERS			
		QTY.	HP	WATTS	FLA TOTAL	MCA (A)	MAX. FUSE (AMPS)	TOTAL WATTS	TOTAL AMPS	MCA (A)	MAX. FUSE (AMPS)
118M^S5A	6	1	1/3	337	0.7	0.9	15	534	0.9	1.2	15
122M^S5A		1	1/3	337	0.7	0.9	15	534	0.9	1.2	15
228M^S5A		2	1/3	674	1.4	1.6	15	887	1.5	1.9	15
236M^S5A		2	1/3	674	1.4	1.6	15	887	1.5	1.9	15
245M^S5A		2	1/3	674	1.4	1.6	15	887	1.5	1.9	15
355M^S5A		3	1/3	1011	2.1	2.3	15	1240	2.2	2.7	15
368M^S5A		3	1/3	1011	2.1	2.3	15	1240	2.2	2.7	15
480M^S5A		8	4	1/3	1348	2.8	3.0	15	1430	2.5	3.1
488M^S5A	4		1/3	1348	2.8	3.0	15	1430	2.5	3.1	15
116L^S5A	6	1	1/3	337	0.7	0.9	15	534	0.9	1.2	15
119L^S5A		1	1/3	337	0.7	0.9	15	534	0.9	1.2	15
225L^S5A		2	1/3	674	1.4	1.6	15	887	1.5	1.9	15
232L^S5A		2	1/3	674	1.4	1.6	15	887	1.5	1.9	15
240L^S5A		2	1/3	674	1.4	1.6	15	887	1.5	1.9	15
348L^S5A		3	1/3	1011	2.1	2.3	15	1240	2.2	2.7	15
356L^S5A		3	1/3	1011	2.1	2.3	15	1240	2.2	2.7	15
471L^S5A		4	1/3	1348	2.8	3.0	15	1430	2.5	3.1	15
113V^S5A	4	1	1/3	337	0.7	0.9	15	534	0.9	1.2	15
117V^S5A		1	1/3	337	0.7	0.9	15	534	0.9	1.2	15
222V^S5A		2	1/3	674	1.4	1.6	15	887	1.5	1.9	15
228V^S5A		2	1/3	674	1.4	1.6	15	887	1.5	1.9	15
234V^S5A		2	1/3	674	1.4	1.6	15	887	1.5	1.9	15
339V^S5A		3	1/3	1011	2.1	2.3	15	1240	2.2	2.7	15
350V^S5A		3	1/3	1011	2.1	2.3	15	1240	2.2	2.7	15
459V^S5A		4	1/3	1348	2.8	3.0	15	1430	2.5	3.1	15

^ = T or G. Refer to Nomenclature for details

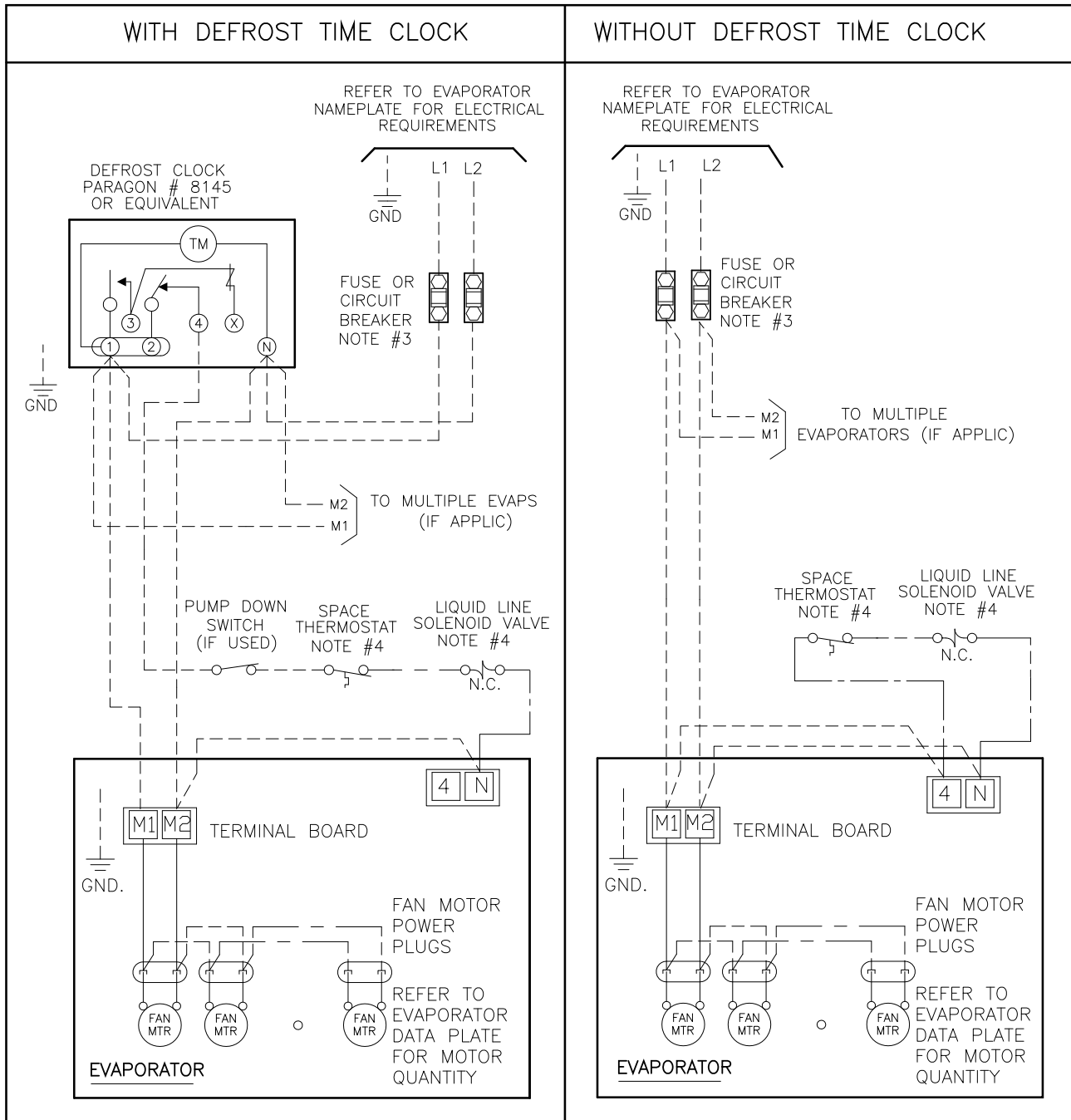

NOTES

- 1). USE COPPER CONDUCTORS ONLY
- 2). USE 90°C WIRE (OR HIGHER)
- 3). OVERCURRENT PROTECTION FOR EVAPORATOR FAN MOTORS AND DEFROST HEATERS MUST NOT EXCEED MAXIMUM VALUE SHOWN ON EVAPORATOR NAMEPLATE.
- 4). MAY BE FACTORY INSTALLED-MOUNTED AND WIRED ON EVAPORATOR .

1-MP AIR 230V 11/05

TERMINALS

- -COMPONENT TERMINAL
- -TERMINAL BLOCK TERMINAL

CONDUCTORS/WIRING

- FACTORY WIRING
- - - - - WIRING BY OTHERS
- OPTIONAL FACTORY OR BY OTHERS

ALL FIELD WIRING MUST BE DONE IN COMPLIANCE WITH ALL APPLICABLE LOCAL AND NATIONAL CODES.

# WIRING DIAGRAM - 460/1/60, 575/1/60 AIR DEFROST MODELS

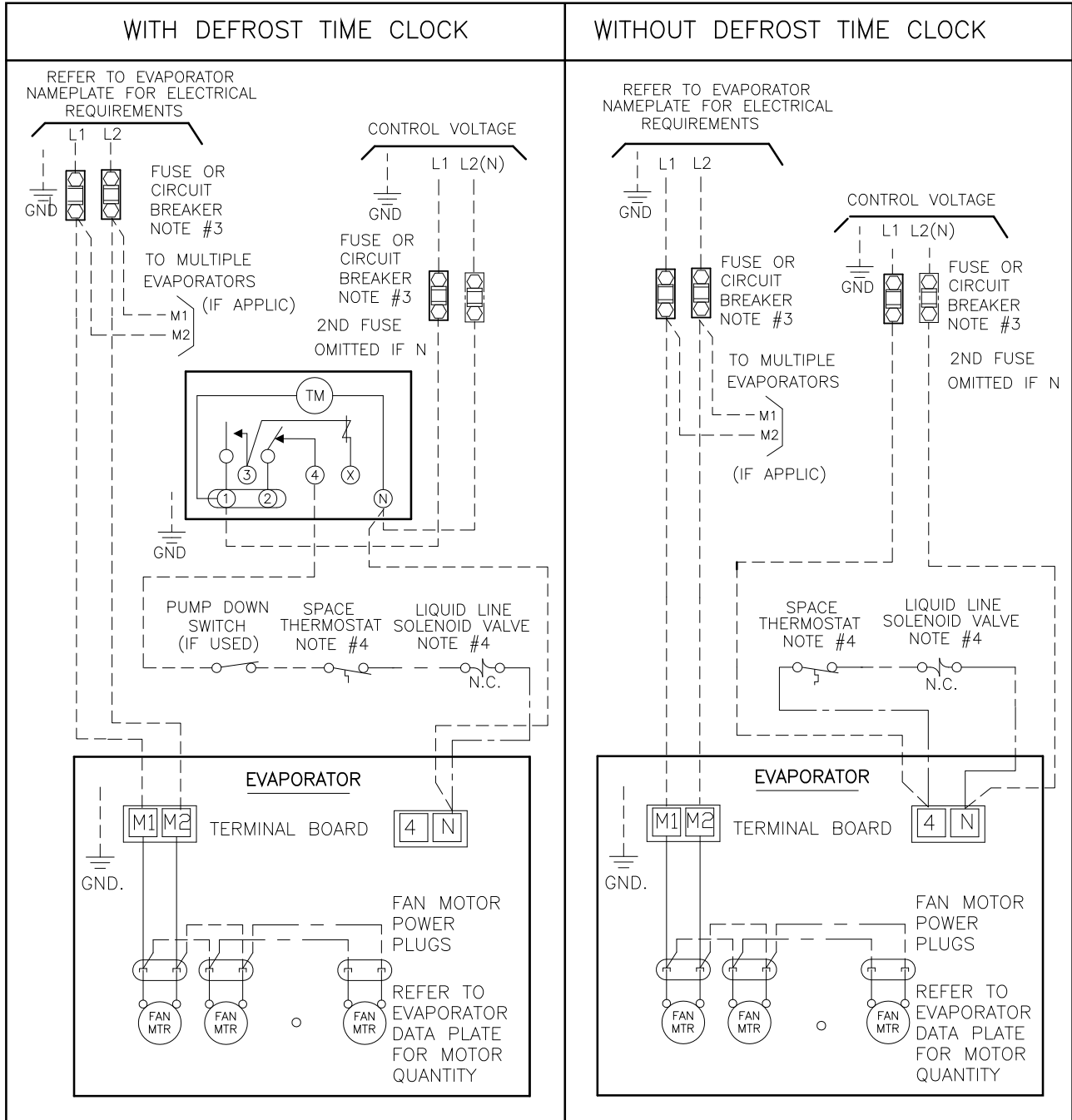

NOTES

- 1). USE COPPER CONDUCTORS ONLY
- 2). USE 90°C WIRE (OR HIGHER)
- 3). OVERCURRENT PROTECTION FOR EVAPORATOR FAN MOTORS AND DEFROST HEATERS MUST NOT EXCEED MAXIMUM VALUE SHOWN ON EVAPORATOR NAMEPLATE.
- 4). MAY BE FACTORY INSTALLED-MOUNTED AND WIRED ON EVAPORATOR .

2-MP AIR 460-575 10/05

TERMINALS

- -COMPONENT TERMINAL
- -TERMINAL BLOCK TERMINAL

CONDUCTORS/WIRING

- FACTORY WIRING
- - - - - WIRING BY OTHERS
- ———— OPTIONAL FACTORY OR BY OTHERS

ALL FIELD WIRING MUST BE DONE IN COMPLIANCE WITH ALL APPLICABLE LOCAL AND NATIONAL CODES.

# WIRING DIAGRAM - 208-230/1/60, 460/1/60, 575/1/60

## ELECTRIC DEFROST MODELS -SINGLE EVAPORATOR

FOR ALL MODELS USING DEFROST HEATER CONTACTOR AND FAN CONTACTOR

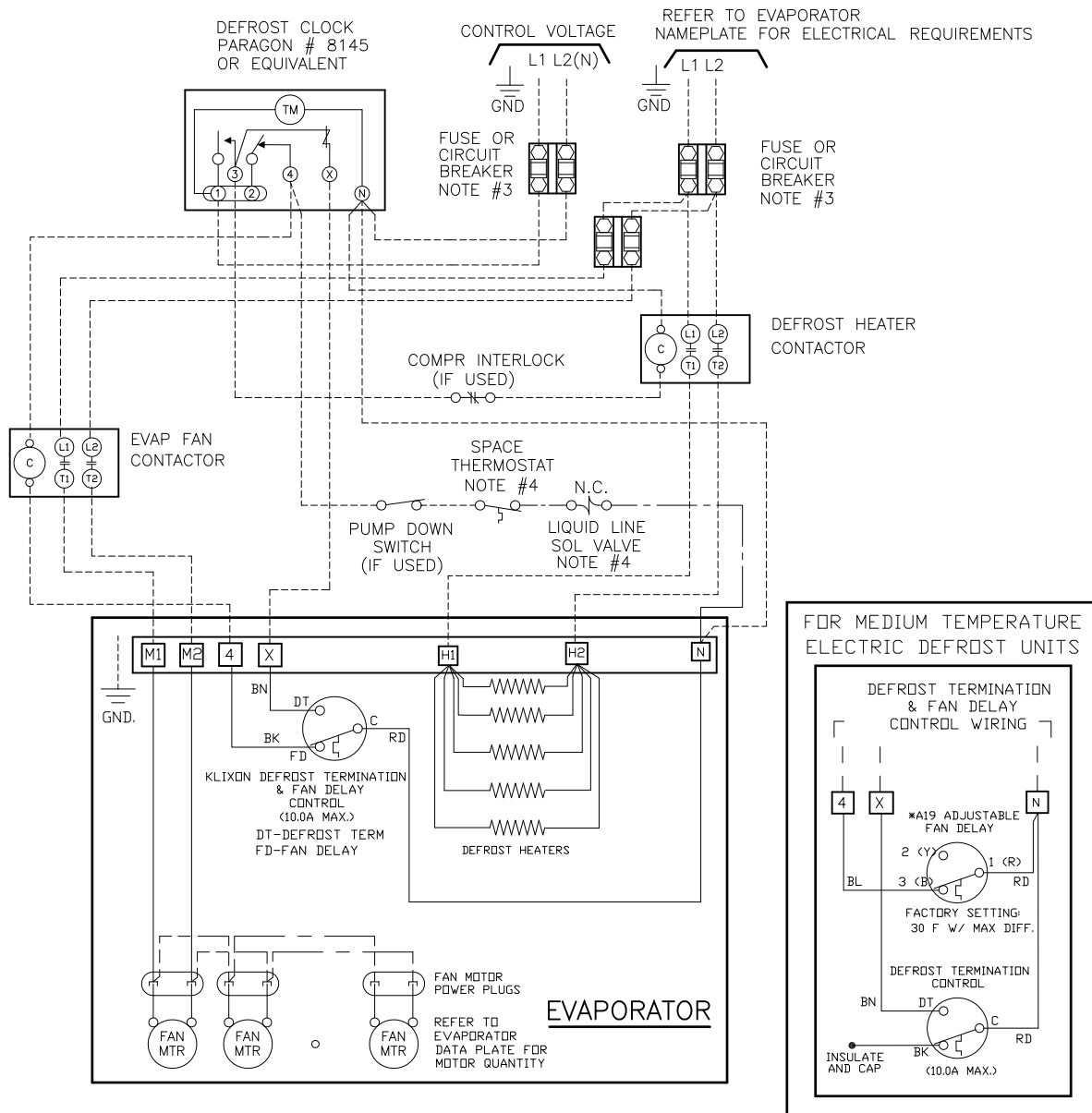

NOTES

- 1). USE COPPER CONDUCTORS ONLY
- 2). USE 90°C WIRE (OR HIGHER)
- 3). OVERCURRENT PROTECTION FOR EVAPORATOR FAN MOTORS AND DEFROST HEATERS MUST NOT EXCEED MAXIMUM VALUE SHOWN ON EVAPORATOR NAMEPLATE.
- 4.) MAY BE FACTORY INSTALLED-MOUNTED AND WIRED ON EVAPORATOR

4A-MP ED 1 ph. ALL SINGLE 07/16

TERMINALS

- -COMPONENT TERMINAL
- -TERMINAL BLOCK TERMINAL

CONDUCTORS/WIRING

- FACTORY WIRING
- WIRING BY OTHERS
- OPTIONAL FACTORY OR BY OTHERS

ALL FIELD WIRING MUST BE DONE IN COMPLIANCE WITH ALL APPLICABLE LOCAL AND NATIONAL CODES.

# WIRING DIAGRAM - 208-230/3/60 ELECTRIC DEFROST MODELS WITHOUT FAN CONTACTOR

FOR ALL MODELS USING THREE PHASE DEFROST HEATER CONTACTOR  
WITHOUT FAN CONTACTOR

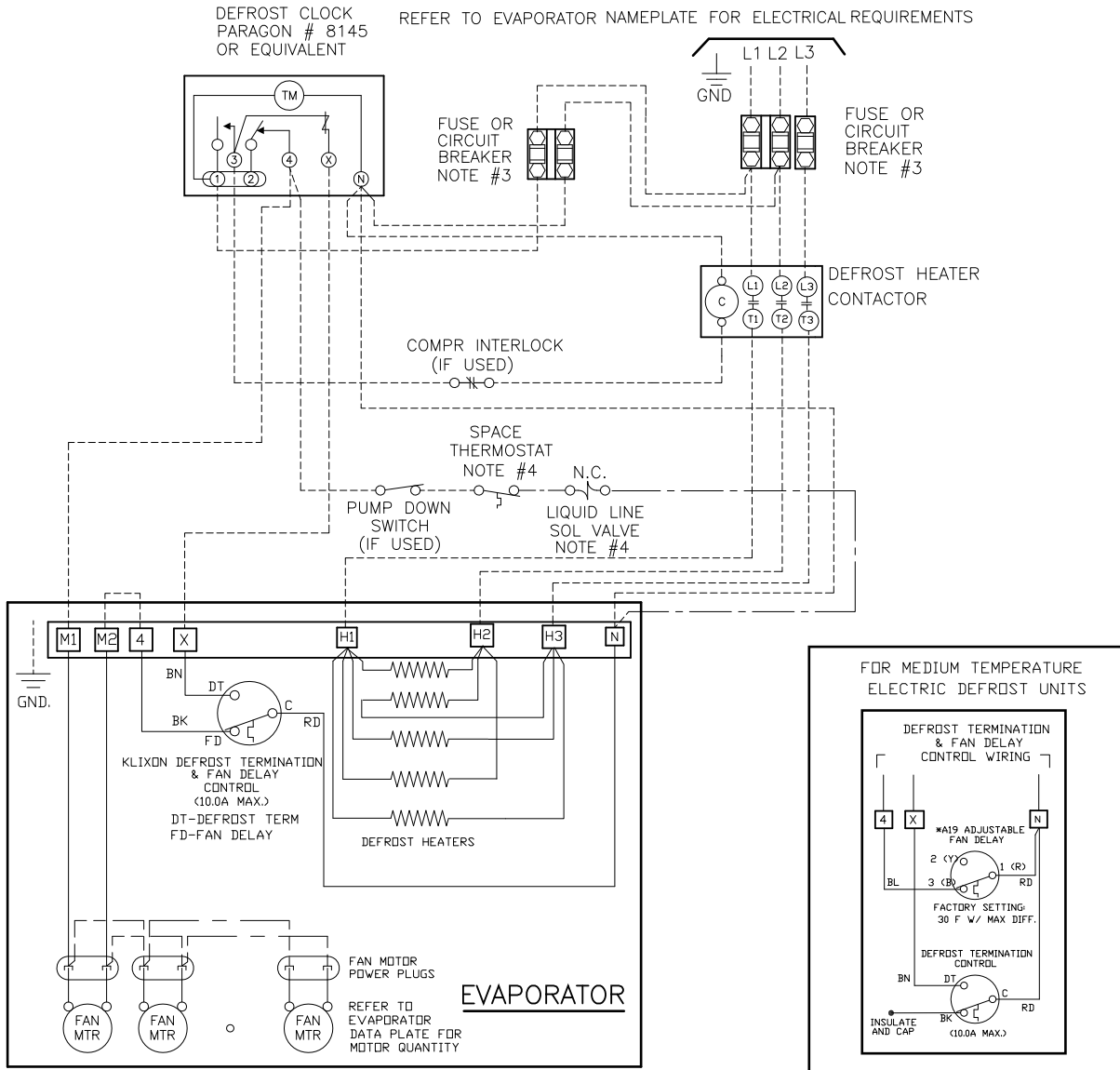

NOTES

- 1). USE COPPER CONDUCTORS ONLY
- 2). USE 90°C WIRE (OR HIGHER)
- 3). OVERCURRENT PROTECTION FOR EVAPORATOR FAN MOTORS AND DEFROST HEATERS MUST NOT EXCEED MAXIMUM VALUE SHOWN ON EVAPORATOR NAMEPLATE.
- 4.) MAY BE FACTORY INSTALLED-MOUNTED AND WIRED ON EVAPORATOR

TERMINALS

- -COMPONENT TERMINAL
- -TERMINAL BLOCK TERMINAL

CONDUCTORS/WIRING

- FACTORY WIRING
- WIRING BY OTHERS
- - - - - OPTIONAL FACTORY OR BY OTHERS

ALL FIELD WIRING MUST BE DONE IN COMPLIANCE WITH ALL APPLICABLE LOCAL AND NATIONAL CODES.

3-MP ED 230V single 7/16

## ELECTRIC DEFROST MODELS - SINGLE EVAPORATOR

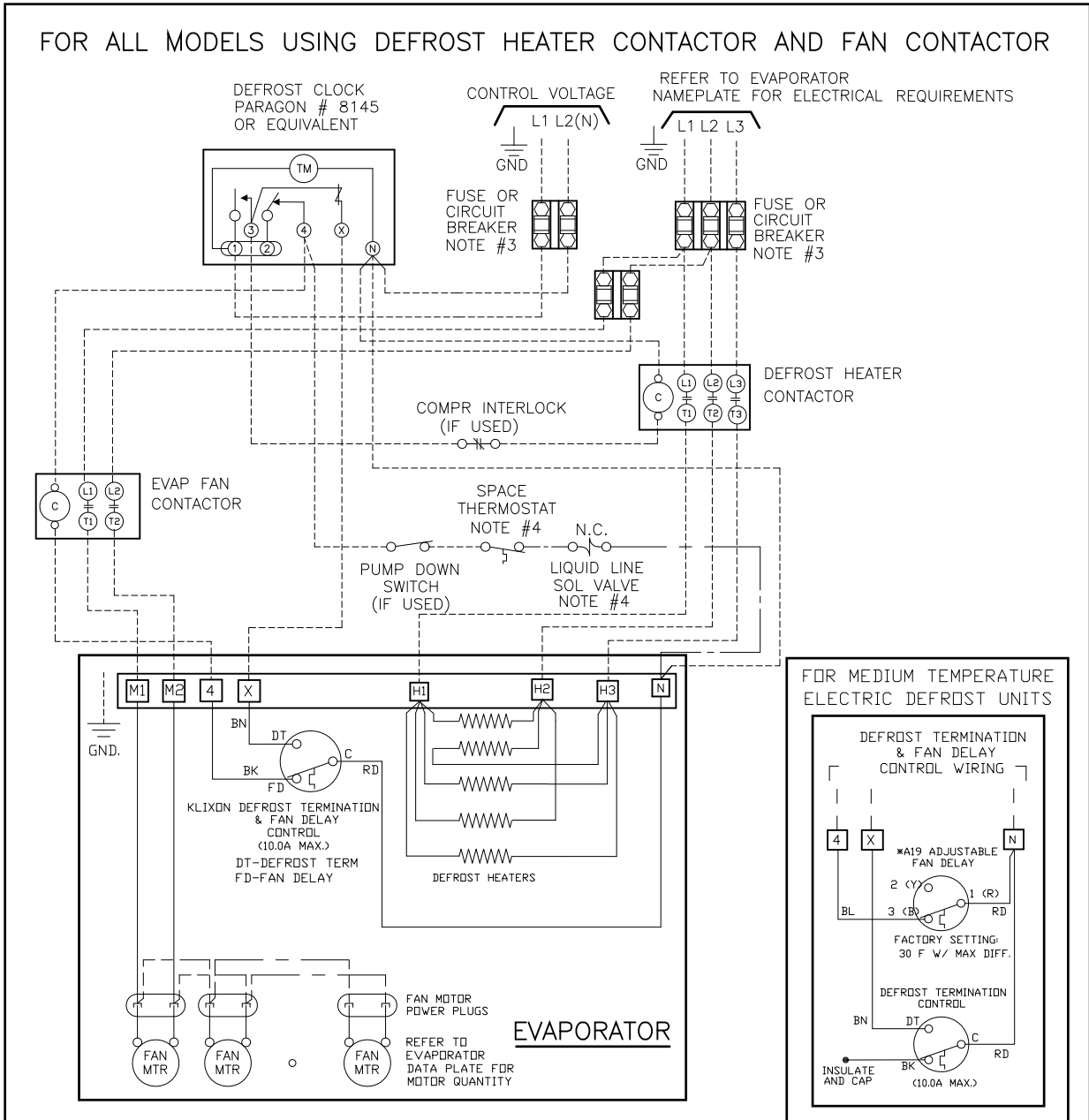

NOTES

- 1.) USE COPPER CONDUCTORS ONLY
- 2.) USE 90°C WIRE (OR HIGHER)
- 3.) OVERCURRENT PROTECTION FOR EVAPORATOR FAN MOTORS AND DEFROST HEATERS MUST NOT EXCEED MAXIMUM VALUE SHOWN ON EVAPORATOR NAMEPLATE.
- 4.) MAY BE FACTORY INSTALLED-MOUNTED AND WIRED ON EVAPORATOR

4-MP ED ALL SINGLE 7/16

TERMINALS

- -COMPONENT TERMINAL
- -TERMINAL BLOCK TERMINAL

CONDUCTORS/WIRING

- FACTORY WIRING
- WIRING BY OTHERS
- · — · — OPTIONAL FACTORY OR BY OTHERS

ALL FIELD WIRING MUST BE DONE IN COMPLIANCE WITH ALL APPLICABLE LOCAL AND NATIONAL CODES.



# WIRING DIAGRAM - 208-230/3/60, 460/3/60, 575/3/60 ELECTRIC DEFROST MODELS - MULTIPLE SINGLE PHASE EVAPORATORS

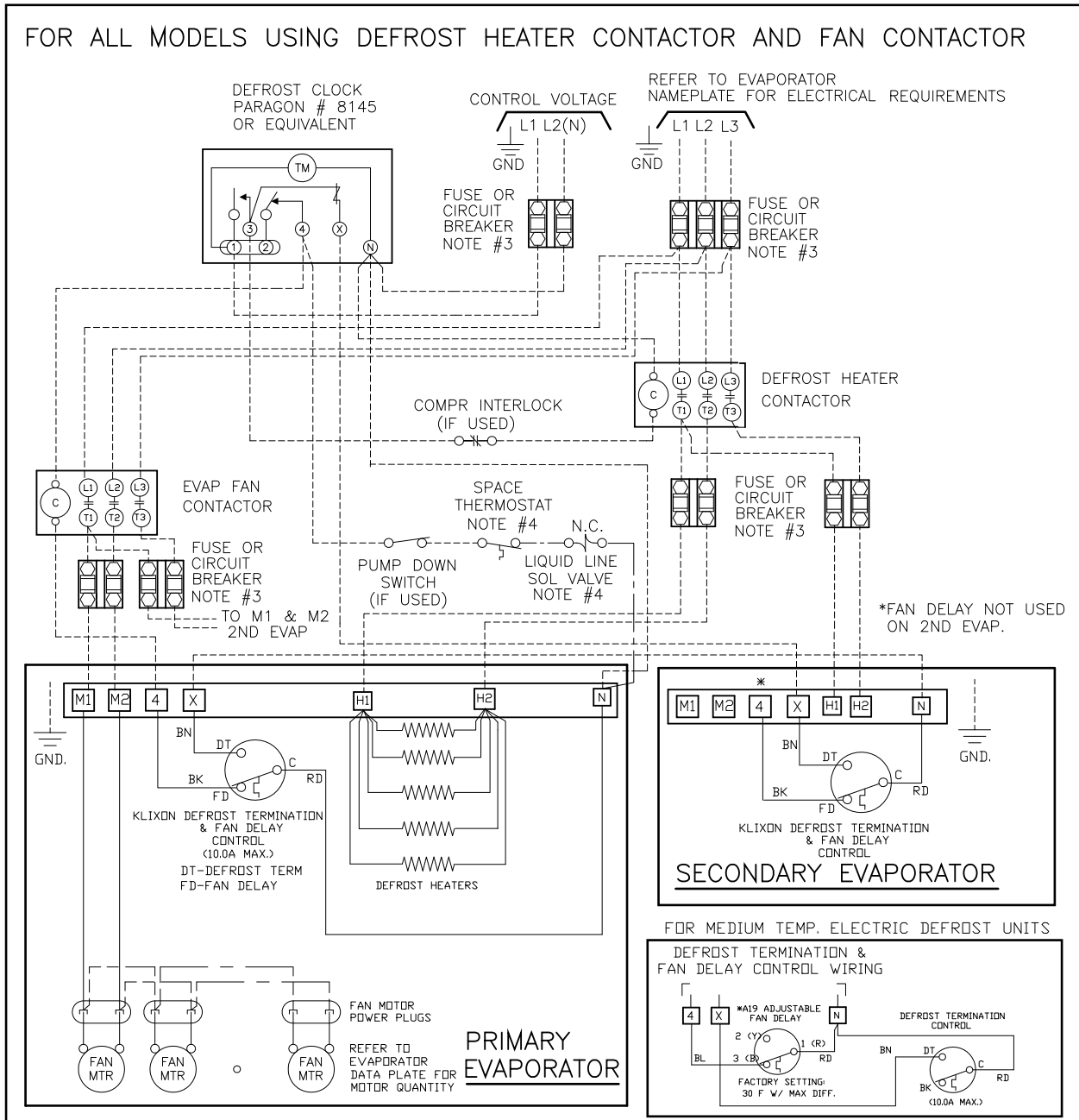

NOTES

- 1). USE COPPER CONDUCTORS ONLY
- 2). USE 90°C WIRE (OR HIGHER)
- 3). OVERCURRENT PROTECTION FOR EVAPORATOR FAN MOTORS AND DEFROST HEATERS MUST NOT EXCEED MAXIMUM VALUE SHOWN ON EVAPORATOR NAMEPLATE.
- 4.) MAY BE FACTORY INSTALLED-MOUNTED AND WIRED ON EVAPORATOR

TERMINALS

- -COMPONENT TERMINAL
- -TERMINAL BLOCK TERMINAL

CONDUCTORS/WIRING

- FACTORY WIRING
- - - - - WIRING BY OTHERS
- OPTIONAL FACTORY OR BY OTHERS

ALL FIELD WIRING MUST BE DONE IN COMPLIANCE WITH ALL APPLICABLE LOCAL AND NATIONAL CODES.

# WIRING DIAGRAM - 208-230/3/60, 460/3/60, 575/3/60 ELECTRIC DEFROST MODELS - MULTIPLE THREE PHASE EVAPORATORS

FOR ALL MODELS USING DEFROST HEATER CONTACTOR AND FAN CONTACTOR

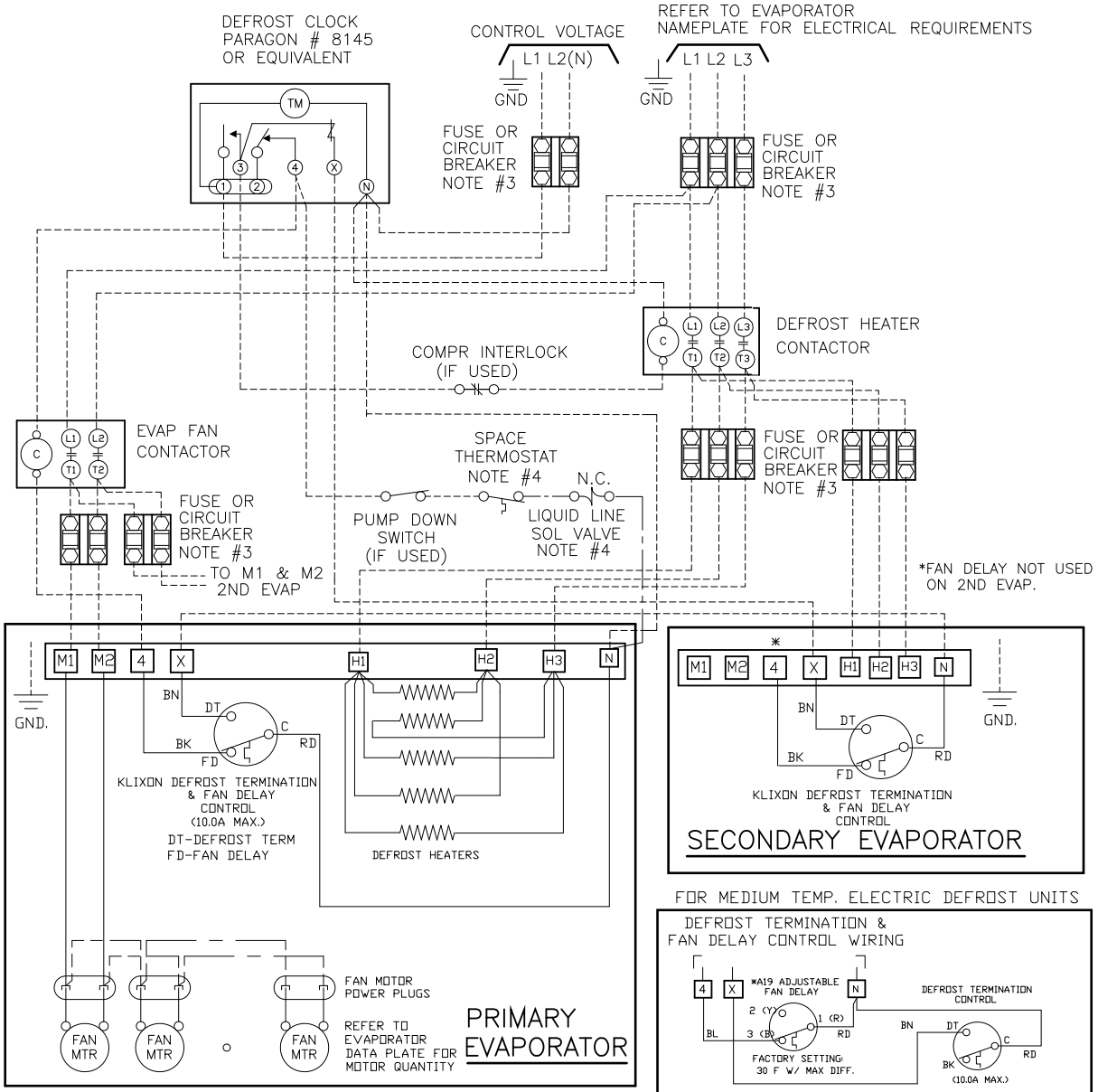

NOTES

- 1). USE COPPER CONDUCTORS ONLY
- 2). USE 90°C WIRE (OR HIGHER)
- 3). OVERCURRENT PROTECTION FOR EVAPORATOR FAN MOTORS AND DEFROST HEATERS MUST NOT EXCEED MAXIMUM VALUE SHOWN ON EVAPORATOR NAMEPLATE.
- 4). MAY BE FACTORY INSTALLED-MOUNTED AND WIRED ON EVAPORATOR

5-MP ED ALL MULTI 07/16

TERMINALS

- -COMPONENT TERMINAL
- -TERMINAL BLOCK TERMINAL

CONDUCTORS/WIRING

- FACTORY WIRING
- WIRING BY OTHERS
- - - - - OPTIONAL FACTORY OR BY OTHERS

ALL FIELD WIRING MUST BE DONE IN COMPLIANCE WITH ALL APPLICABLE LOCAL AND NATIONAL CODES.

# WIRING DIAGRAM - 208-230/1/60 HOT GAS DEFROST MODELS

## USING MAXIMUM 15A HEATER OVERCURRENT PROTECTION

REFER TO EVAPORATOR NAMEPLATE FOR ELECTRICAL REQUIREMENTS

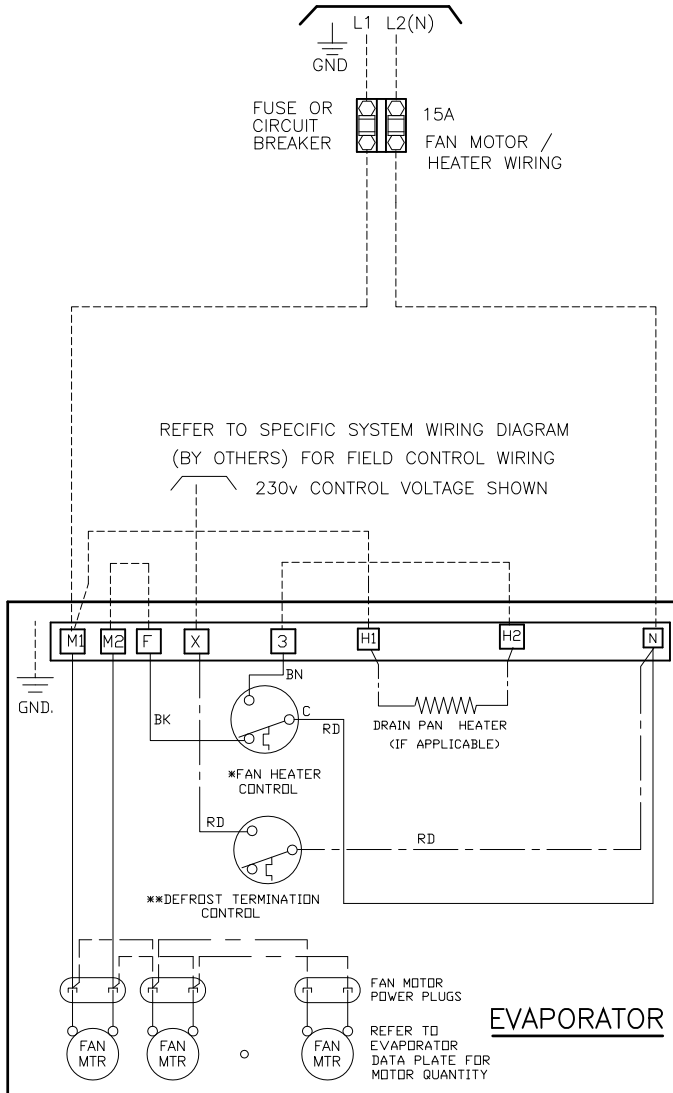

**\*FAN HEATER CONTROL**  
ON REVERSE CYCLE LOCATED AT SUCTION LINE.  
ON THREE-PIPE LOCATED AT DISTRIBUTOR SIDE PORT.  
NOTE: DURING THE HOT GAS DEFROST CYCLE THE FAN/HEATER CONTROL DE-ENERGIZES THE EVAPORATOR FANS AND ENERGIZES THE DRAIN PAN HEATER.  
(ANYTIME THE TEMPERATURE OF THE INCOMING REFRIGERANT GAS IS ABOVE 50° F).  
ON MEDIUM TEMPERATURE UNITS AN ADJUSTABLE FAN DELAY IS PROVIDED.

**\*\*DEFROST TERMINATION CONTROL**  
OPTIONAL FACTORY WIRED OR BY OTHERS  
LOCATED ON TUBE END SHEET  
THE CONTROL CLOSSES WHEN REACHES 55° F (20 F DIFF)

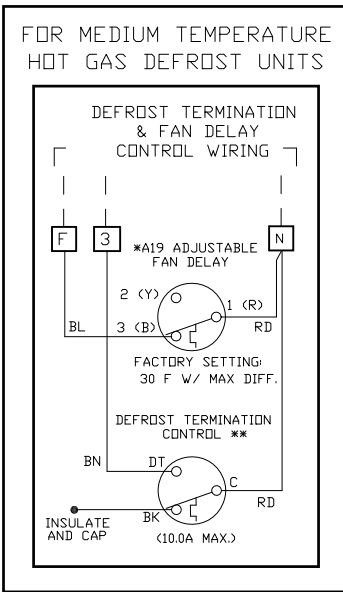

NOTES

- 1.) USE COPPER CONDUCTORS ONLY
- 2.) USE 90°C WIRE (OR HIGHER)
- 3.) OVERCURRENT PROTECTION FOR EVAPORATOR FAN MOTORS AND DEFROST HEATERS MUST NOT EXCEED MAXIMUM VALUE SHOWN ON EVAPORATOR NAMEPLATE.
- 4.) MAY BE FACTORY INSTALLED-MOUNTED AND WIRED ON EVAPORATOR

TERMINALS

- -COMPONENT TERMINAL
- -TERMINAL BLOCK TERMINAL

CONDUCTORS/WIRING

- FACTORY WIRING
- WIRING BY OTHERS
- — — — — OPTIONAL FACTORY OR BY OTHERS

ALL FIELD WIRING MUST BE DONE IN COMPLIANCE WITH ALL APPLICABLE LOCAL AND NATIONAL CODES.

6-MP HG 230V 07/16

# WIRING DIAGRAM - 460/1/60, 575/1/60 HOT GAS DEFROST MODELS

USING FAN CONTACTOR ( AND HEATER CONTACTOR IF APPLICABLE )

REFER TO EVAPORATOR NAMEPLATE FOR ELECTRICAL REQUIREMENTS

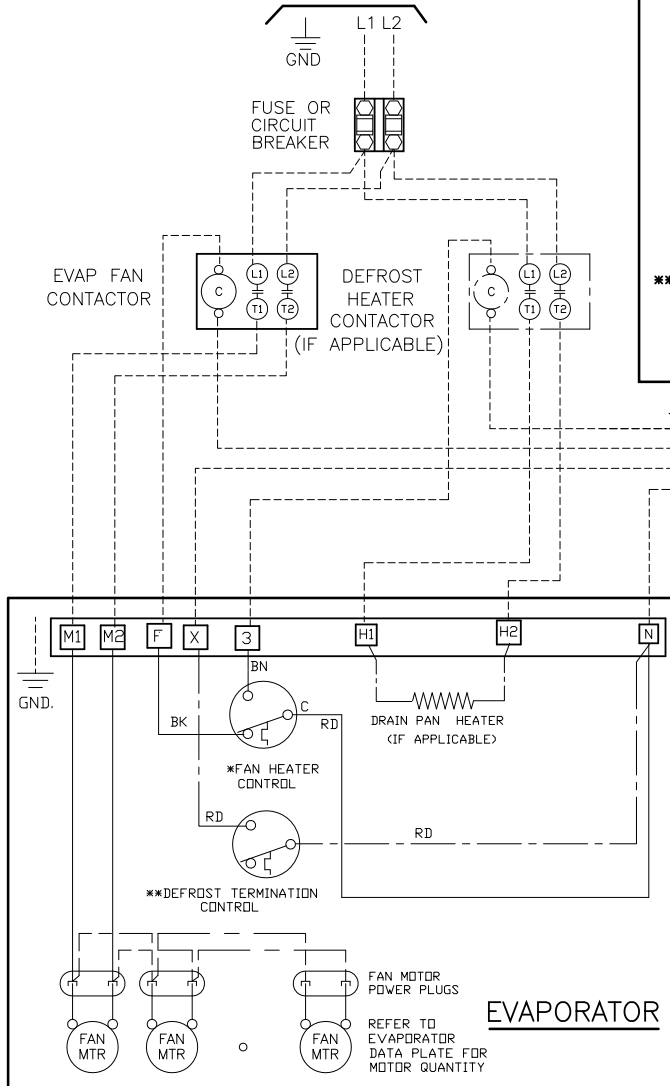

**\*FAN HEATER CONTROL**  
ON REVERSE CYCLE LOCATED AT SUCTION LINE.  
ON THREE-PIPE LOCATED AT DISTRIBUTOR SIDE PORT.  
NOTE: DURING THE HOT GAS DEFROST CYCLE THE FAN/HEATER CONTROL DE-ENERGIZES THE EVAPORATOR FANS AND ENERGIZES THE DRAIN PAN HEATER.  
(ANYTIME THE TEMPERATURE OF THE INCOMING REFRIGERANT GAS IS ABOVE 50° F).  
ON MEDIUM TEMPERATURE UNITS AN ADJUSTABLE FAN DELAY IS PROVIDED.

**\*\*DEFROST TERMINATION CONTROL**  
OPTIONAL FACTORY WIRED OR BY OTHERS LOCATED ON TUBE END SHEET  
THE CONTROL CLOSES WHEN REACHES 55° F (20 F DIFF)

REFER TO SPECIFIC SYSTEM WIRING DIAGRAM (BY OTHERS) FOR FIELD CONTROL WIRING

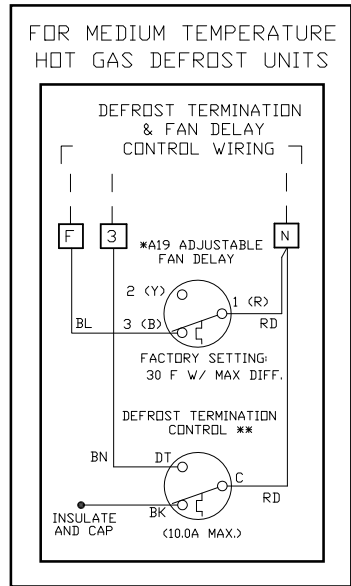

NOTES

- 1). USE COPPER CONDUCTORS ONLY
- 2). USE 90°C WIRE (OR HIGHER)
- 3). OVERCURRENT PROTECTION FOR EVAPORATOR FAN MOTORS AND DEFROST HEATERS MUST NOT EXCEED MAXIMUM VALUE SHOWN ON EVAPORATOR NAMEPLATE.
- 4.) MAY BE FACTORY INSTALLED-MOUNTED AND WIRED ON EVAPORATOR

7-MP ALL HG 07/16

TERMINALS

- -COMPONENT TERMINAL
- -TERMINAL BLOCK TERMINAL

CONDUCTORS/WIRING

- FACTORY WIRING
- - - - - WIRING BY OTHERS
- · — · — · — OPTIONAL FACTORY OR BY OTHERS

ALL FIELD WIRING MUST BE DONE IN COMPLIANCE WITH ALL APPLICABLE LOCAL AND NATIONAL CODES.

US Patents Nos.  
8,635,883  
& 9,151,525



## DESIGN FEATURES

- NO special controls required.
- Refrigeration mode – EC motor operates at full speed.  
Consumption 245 W per motor
- Off Cycle mode – EC motor operates at reduced speed.  
Consumption 70 W per motor.
- Energy saving benefit on motor and compressor wattage consumption:

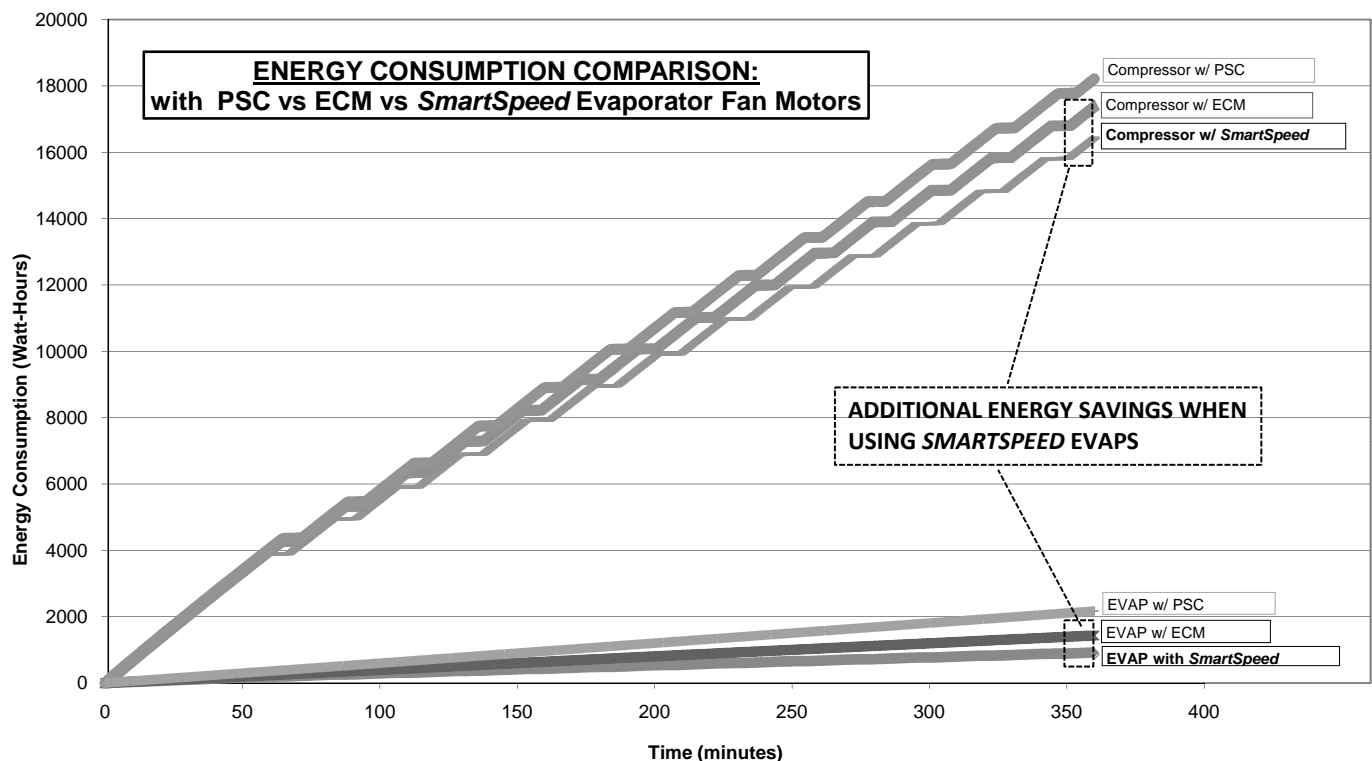

Note: Data collected on a typical freezer application with a 4HP low temp condensing unit and a 1 fan KMP evaporator

## INSTALLATION NOTES

Two-speed EC motors are factory wired for SmartSpeed operation on evaporators equipped **with** a factory installed thermostat.

For SmartSpeed operation on Evaporators **without** a factory installed thermostat, a field wired SPDT type thermostat is required.

# WIRING DIAGRAM - 115/1/60, 208-230/1/60

## OPTIONAL EC MOTORS with SMARTSPEED™

### AIR DEFROST MODELS

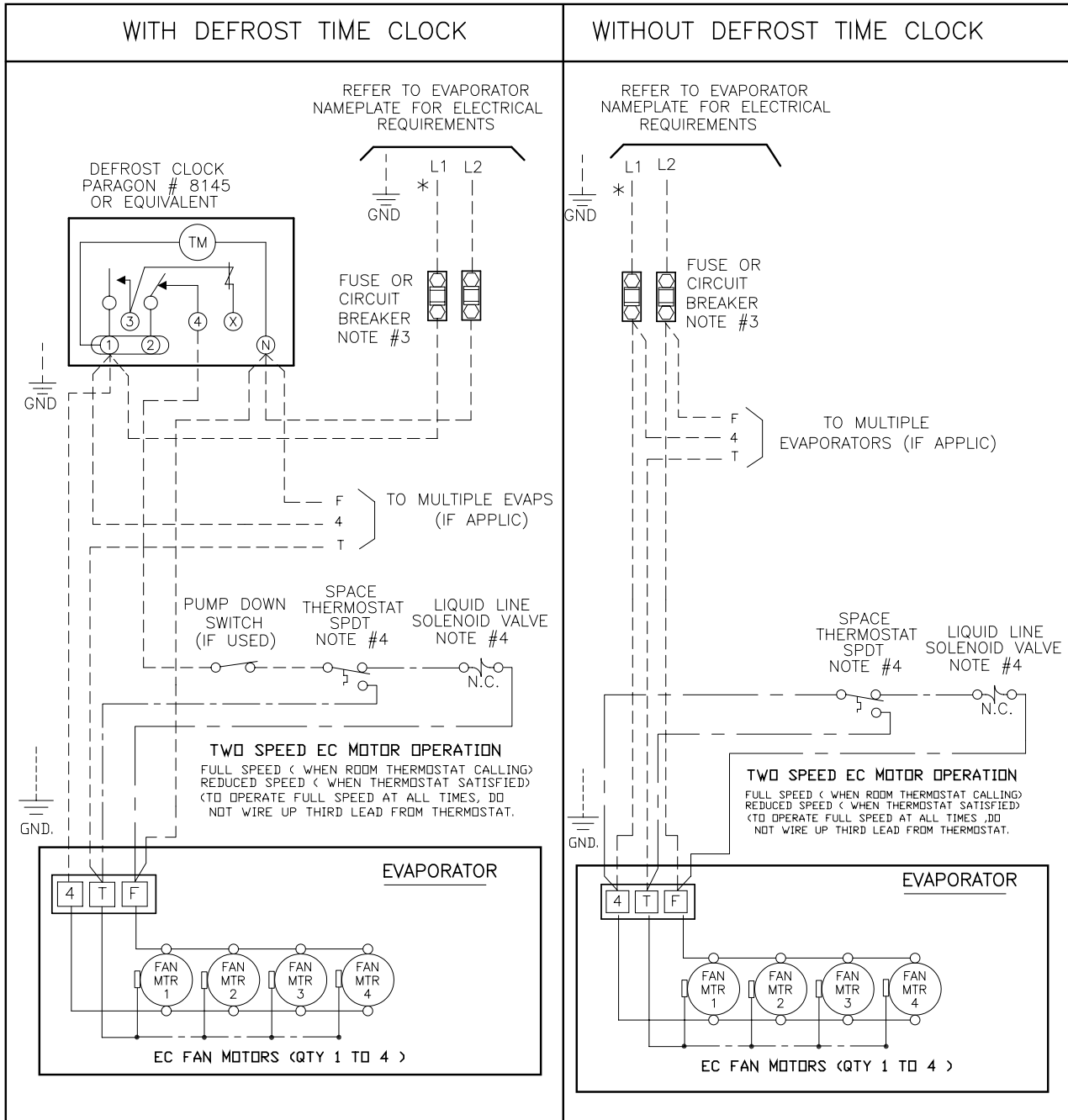

**\* SMARTSPEED WIRING NOTE:**  
FOR SMARTSPEED OPERATION BOTH CONTROL VOLTAGE POWER AND FAN MOTOR POWER MUST ORIGINATE FROM SAME SOURCE.

NOTES

- 1). USE COPPER CONDUCTORS ONLY
- 2). USE 75°C WIRE (OR HIGHER)
- 3). OVERCURRENT PROTECTION FOR EVAPORATOR FAN MOTORS AND DEFROST HEATERS MUST NOT EXCEED MAXIMUM VALUE SHOWN ON EVAPORATOR NAMEPLATE.
- 4). MAY BE FACTORY INSTALLED-MOUNTED AND WIRED ON EVAPORATOR. MUST BE SPDT TYPE IF TWO SPEED MODE IS REQUIRED.

1-MPEC AIR 05/11

TERMINALS

- -COMPONENT TERMINAL
- -TERMINAL BLOCK TERMINAL

CONDUCTORS/WIRING

- FACTORY WIRING
- - - - - WIRING BY OTHERS
- OPTIONAL FACTORY OR BY OTHERS

ALL FIELD WIRING MUST BE DONE IN COMPLIANCE WITH ALL APPLICABLE LOCAL AND NATIONAL CODES.



# WIRING DIAGRAM - 208-230/1/60

## OPTIONAL EC MOTORS with SMARTSPEED™

### ELECTRIC DEFROST MODELS

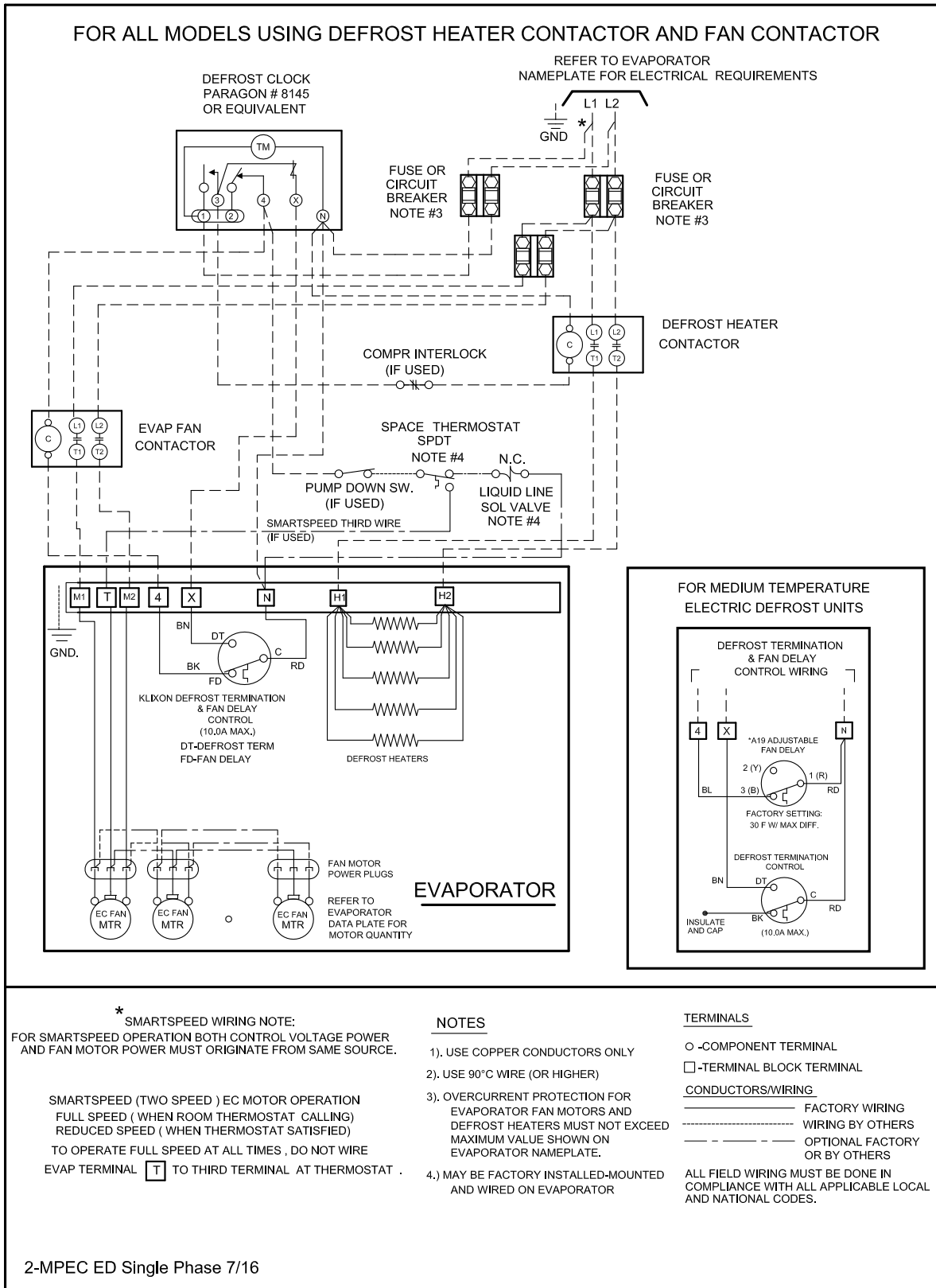

**ELECTRIC DEFROST MODELS - MULTIPLE EVAPORATORS**

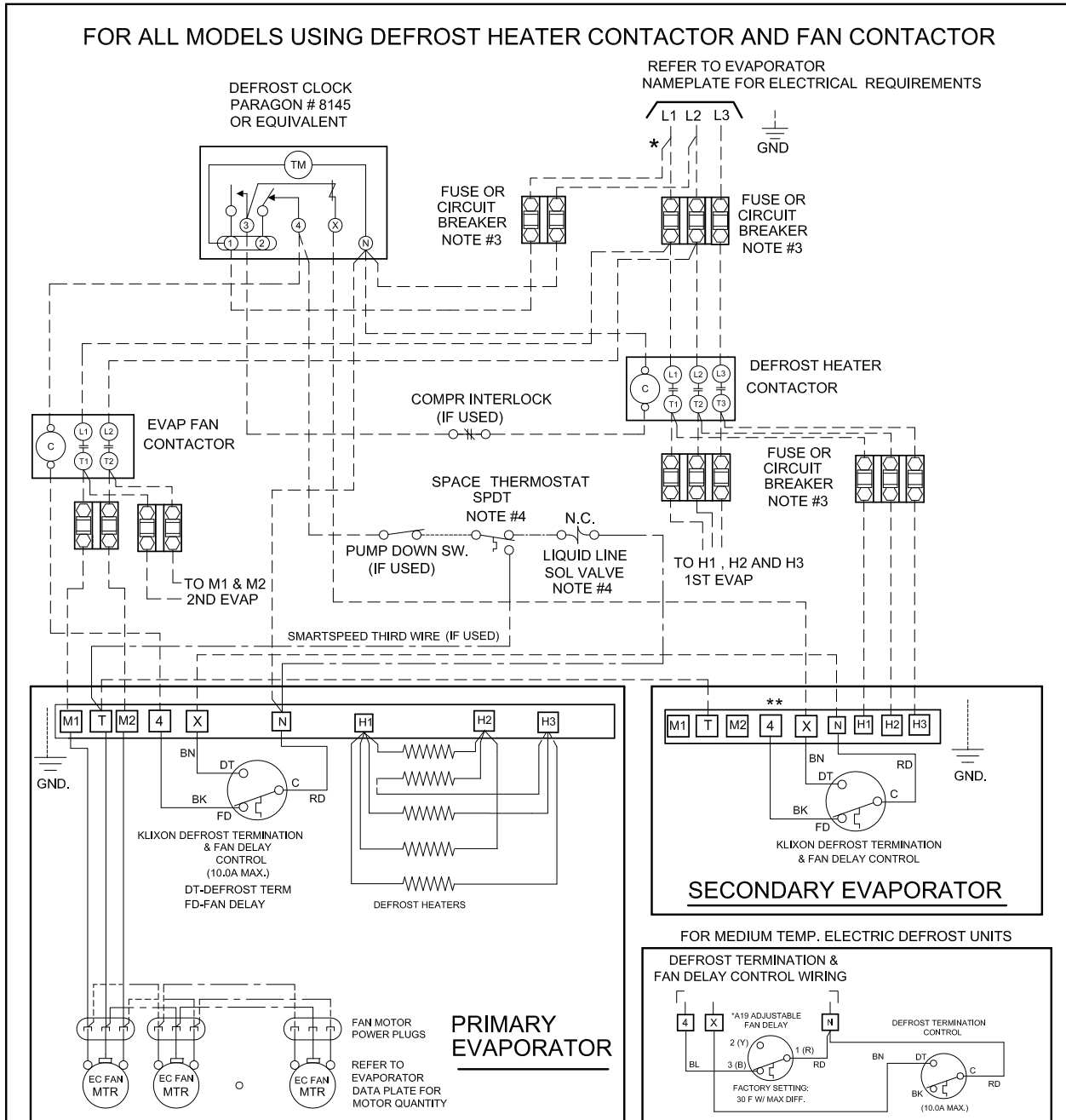

**\* SMARTSPEED WIRING NOTE:**  
 FOR SMARTSPEED OPERATION BOTH CONTROL VOLTAGE POWER AND FAN MOTOR POWER MUST ORIGINATE FROM SAME SOURCE.

SMARTSPEED (TWO SPEED) EC MOTOR OPERATION  
 FULL SPEED (WHEN ROOM THERMOSTAT CALLING)  
 REDUCED SPEED (WHEN THERMOSTAT SATISFIED)  
 TO OPERATE FULL SPEED AT ALL TIMES, DO NOT WIRE  
 EVAP TERMINAL [T] TO THIRD TERMINAL AT THERMOSTAT.

- NOTES**
1. USE COPPER CONDUCTORS ONLY
  2. USE 90°C WIRE (OR HIGHER)
  3. OVERCURRENT PROTECTION FOR EVAPORATOR FAN MOTORS AND DEFROST HEATERS MUST NOT EXCEED MAXIMUM VALUE SHOWN ON EVAPORATOR NAMEPLATE.
  - 4.) MAY BE FACTORY INSTALLED-MOUNTED AND WIRED ON EVAPORATOR

**TERMINALS**

○ -COMPONENT TERMINAL  
 □ -TERMINAL BLOCK TERMINAL

**CONDUCTORS/WIRING**

————— FACTORY WIRING  
 - - - - - WIRING BY OTHERS  
 - - - - - OPTIONAL FACTORY OR BY OTHERS

ALL FIELD WIRING MUST BE DONE IN COMPLIANCE WITH ALL APPLICABLE LOCAL AND NATIONAL CODES.

# WIRING DIAGRAM - 460/1/60 w/ 230V CONTROL

## OPTIONAL EC MOTORS with 2 SPEED OPERATION

### ELECTRIC DEFROST MODELS

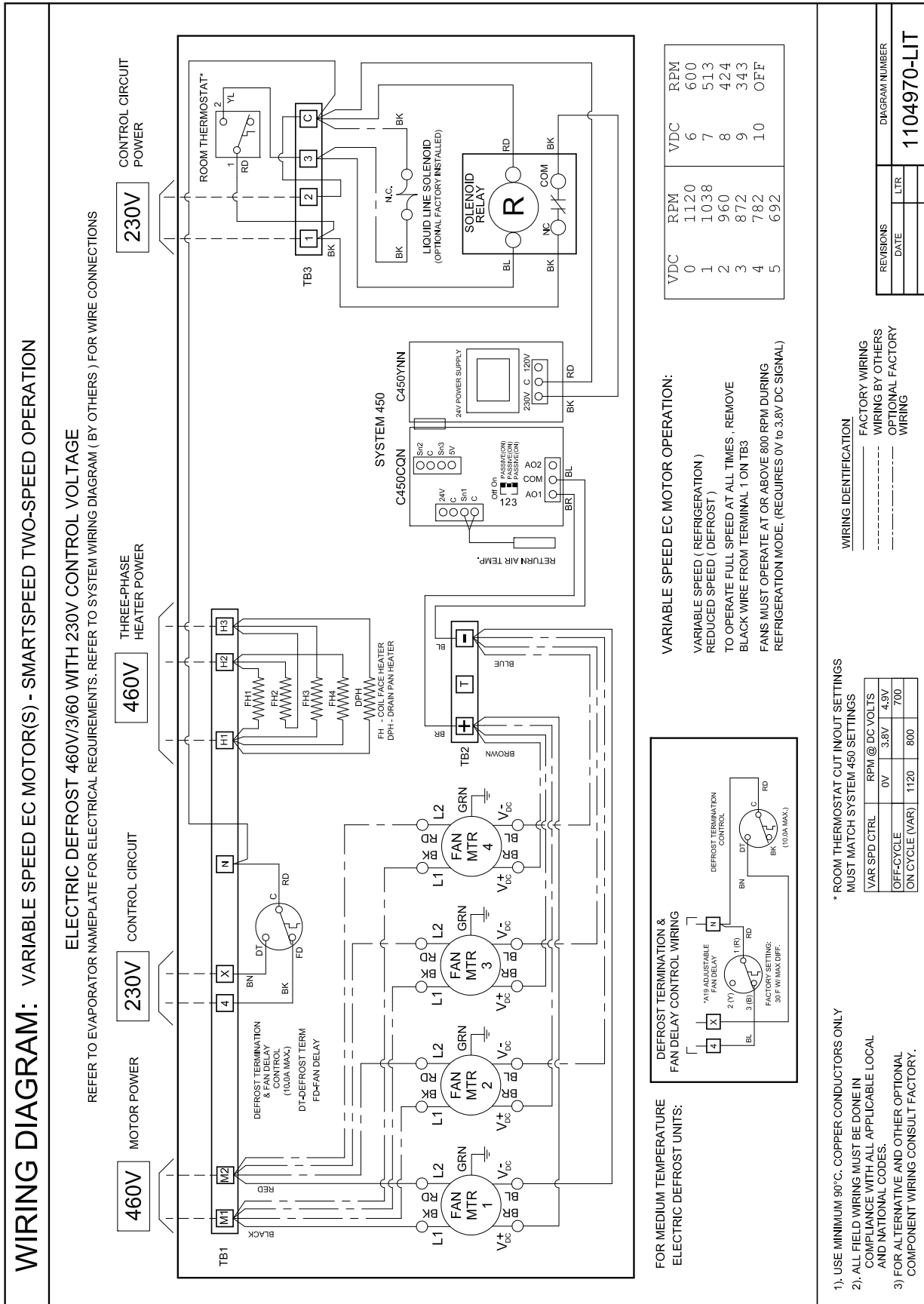

# WIRING DIAGRAM - 208-230V/1/60

## OPTIONAL VARIABLE SPEED EC MOTORS

### AIR DEFROST MODELS

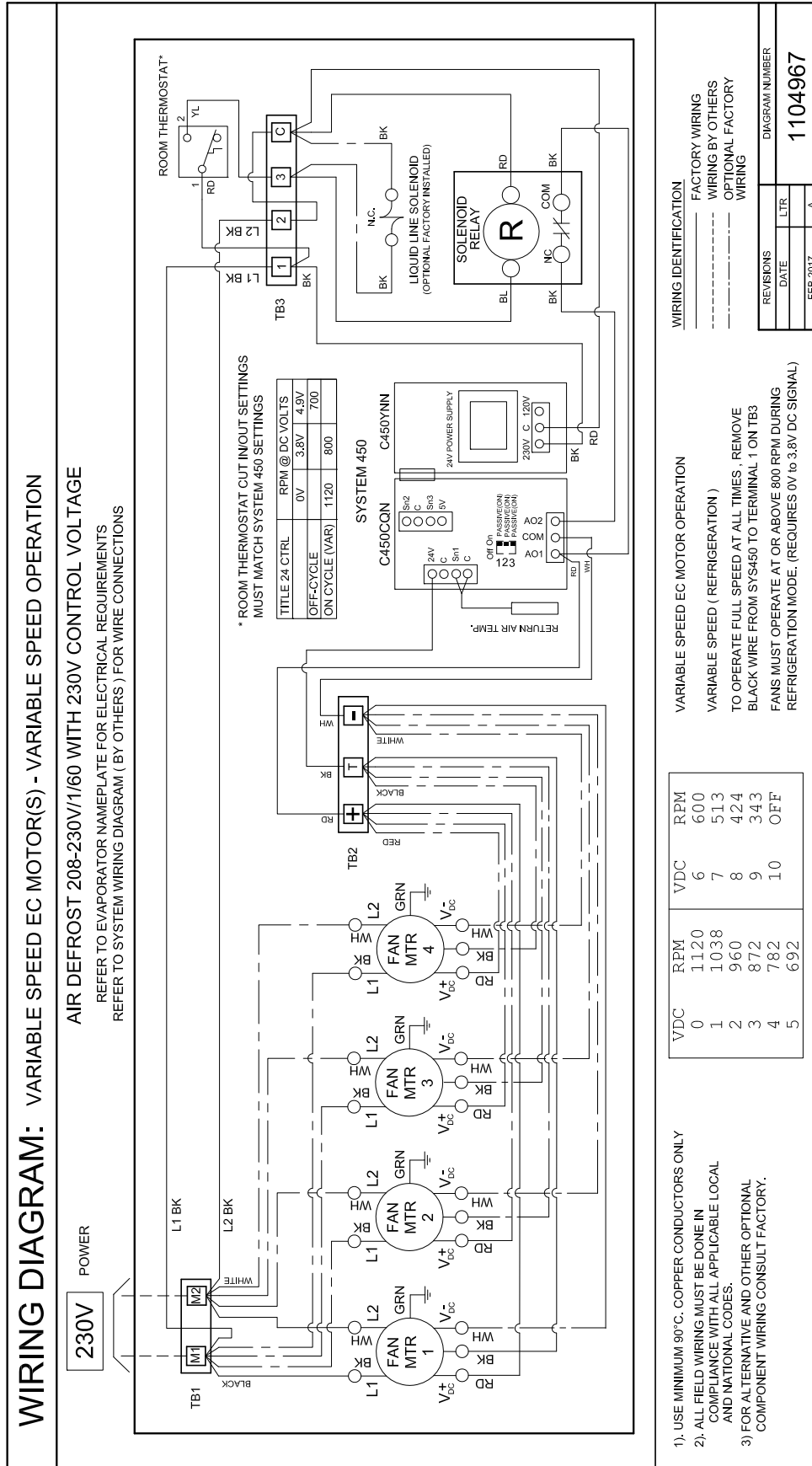

# WIRING DIAGRAM - 460/1/60 w/ 115V CONTROL

## OPTIONAL VARIABLE SPEED EC MOTORS

### AIR DEFROST MODELS

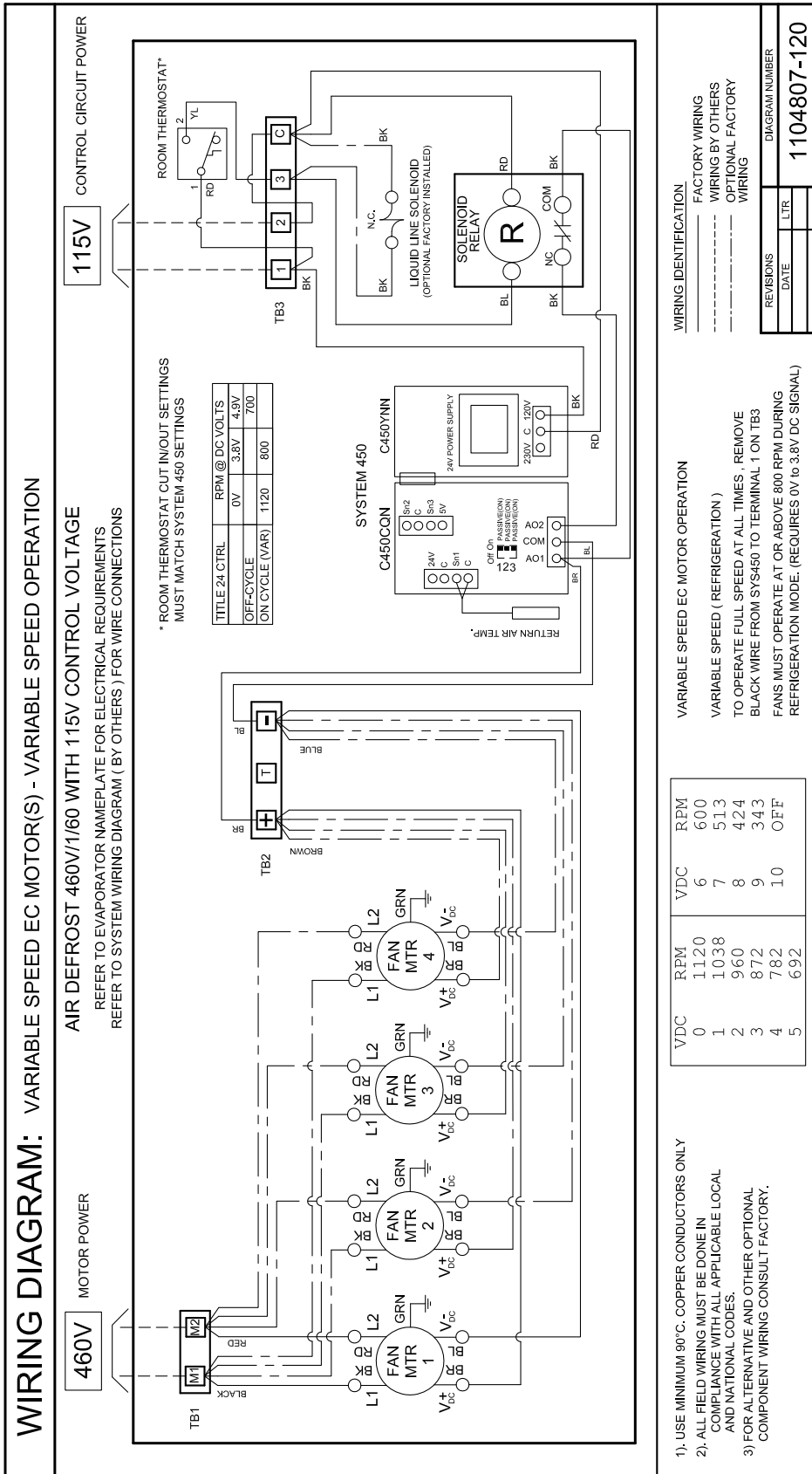

# WIRING DIAGRAM - 460/1/60 w/ 115V CONTROL

## OPTIONAL VARIABLE SPEED EC MOTORS

### ELECTRIC DEFROST MODELS

### WIRING DIAGRAM: VARIABLE SPEED EC MOTOR(S) - VARIABLE SPEED OPERATION

ELECTRIC DEFROST 460V/1/60 WITH 230V CONTROL VOLTAGE

REFER TO EVAPORATOR NAMEPLATE FOR ELECTRICAL REQUIREMENTS. REFER TO SYSTEM WIRING DIAGRAM ( BY OTHERS ) FOR WIRE CONNECTIONS

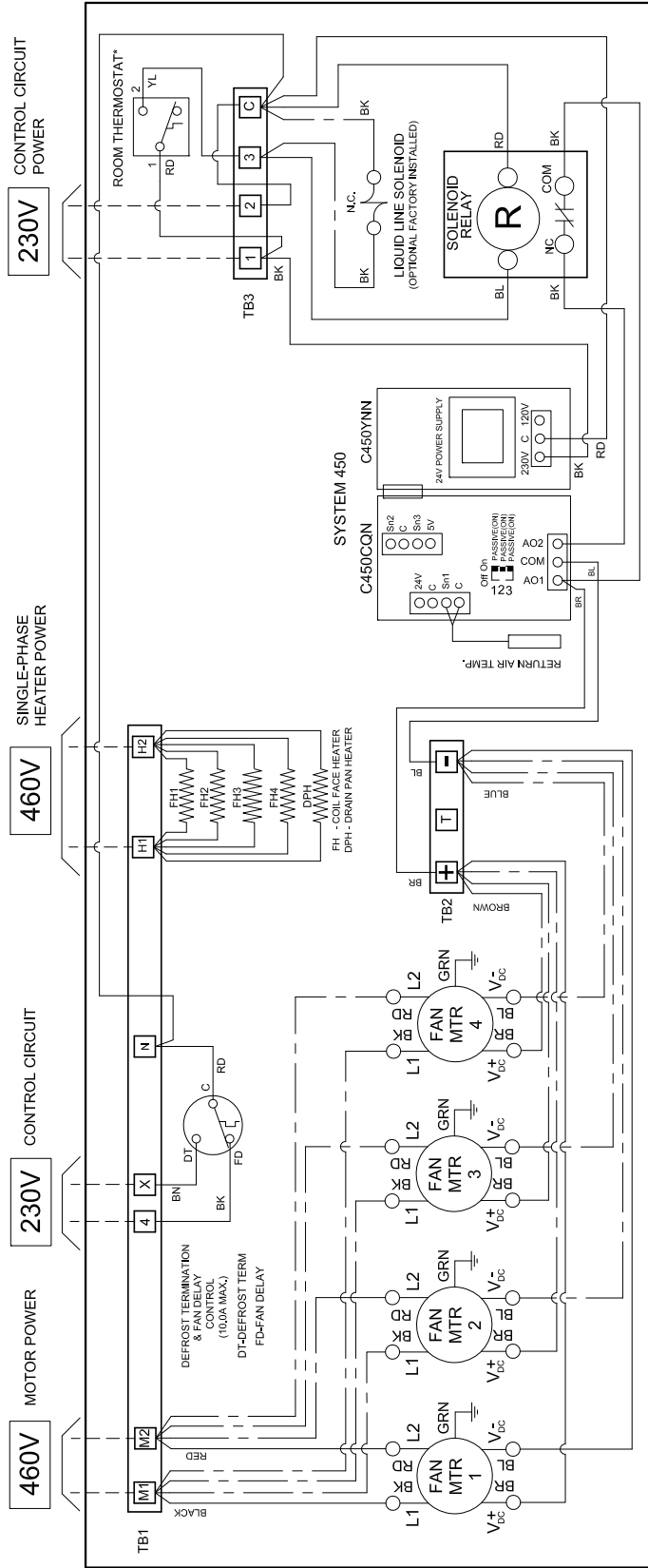

FOR MEDIUM TEMPERATURE ELECTRIC DEFROST UNITS:

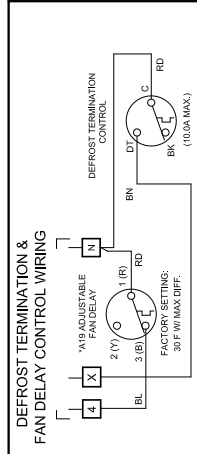

VARIABLE SPEED EC MOTOR OPERATION:

- VARIABLE SPEED ( REFRIGERATION )
- REDUCED SPEED ( DEFROST )
- TO OPERATE FULL SPEED AT ALL TIMES , REMOVE BLACK WIRE FROM TERMINAL 1 ON TB3
- FANS MUST OPERATE AT OR ABOVE 800 RPM DURING REFRIGERATION MODE. (REQUIRES 0V to 3.8V DC SIGNAL)

VDC	RPM	VDC	RPM
0	1120	6	600
1	1038	7	513
2	960	8	424
3	872	9	343
4	782	1.0	OFF
5	692		

- 1). USE MINIMUM 90°C. COPPER CONDUCTORS ONLY
- 2). ALL FIELD WIRING MUST BE DONE IN COMPLIANCE WITH ALL APPLICABLE LOCAL AND NATIONAL CODES.
- 3) FOR ALTERNATIVE AND OTHER OPTIONAL COMPONENT WIRING CONSULT FACTORY.

\* ROOM THERMOSTAT CUT IN/OUT SETTINGS MUST MATCH SYSTEM 450 SETTINGS

VAR SPD CTRL	RPM @ DC VOLTS
0V	3.8V
OFF-CYCLE	4.9V
ON CYCLE (VAR)	700
	800

WIRING IDENTIFICATION  
 \_\_\_\_\_ FACTORY WIRING  
 - - - - - WIRING BY OTHERS  
 . . . . . OPTIONAL FACTORY WIRING

REVISIONS	DATE	LTR	DIAGRAM NUMBER
			1104969-LIT



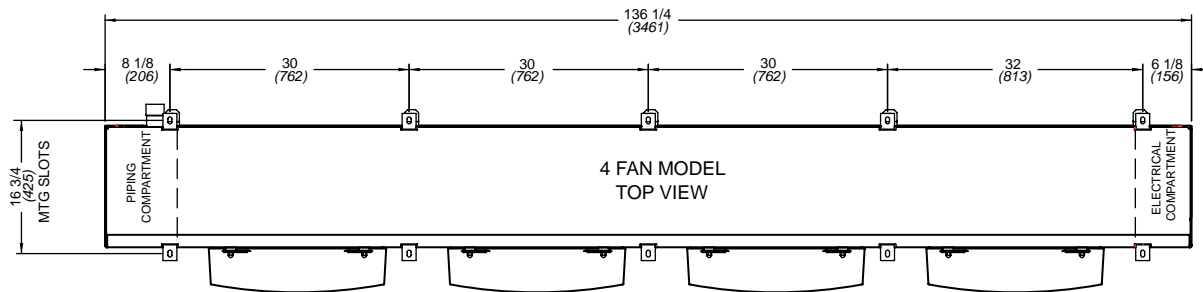
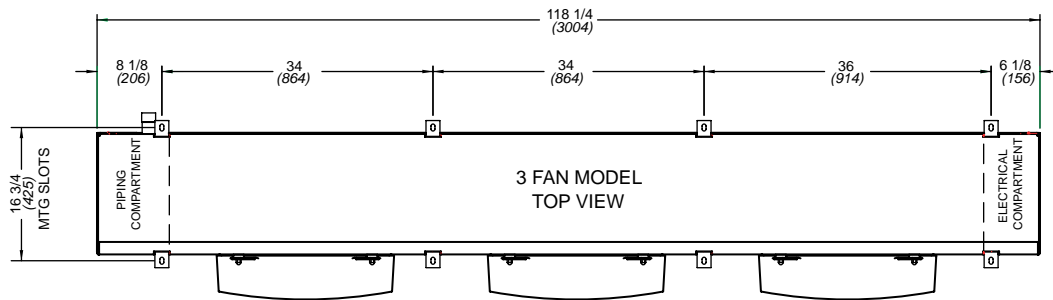
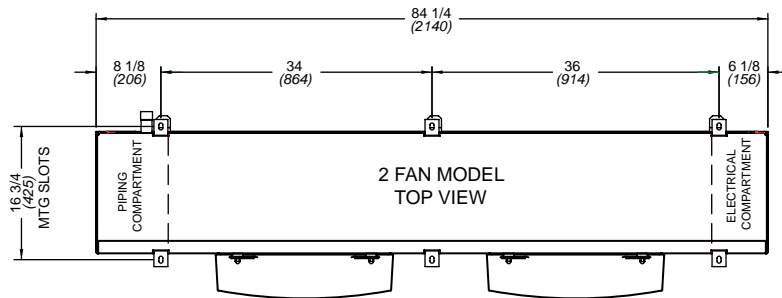
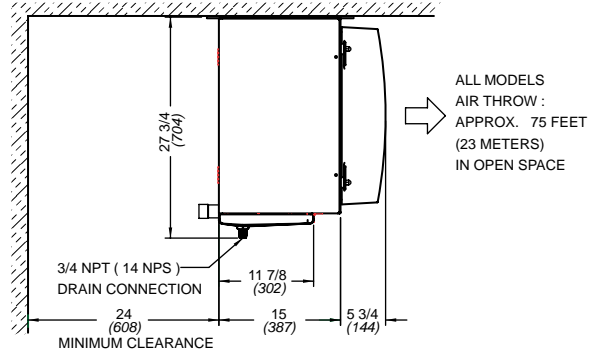
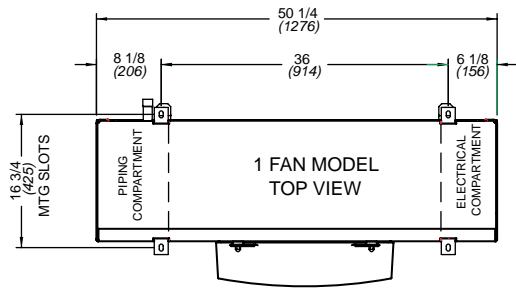

**Medium Temperature Air and Electric Defrost Models**

MODEL KMP	NO. OF FANS	SUCTION CONNECTION (ID) SWEAT	DISTRIBUTOR INLET SIZE
118M#	1	7/8	5/8
122M#	1	1 1/8	5/8
228M#	2	1 1/8	5/8
236M#	2	1 3/8	7/8
245M#	2	1 3/8	1-1/8
355M#	3	1 5/8	1-1/8
368M#	3	1 5/8	1-1/8
480M#	4	1 5/8	1-1/8
488M#	4	1 5/8	1-1/8

# = A or E. Refer to Nomenclature for details

**Low Temperature Electric Defrost Models**

MODEL KMP	NO. OF FANS	SUCTION CONNECTION (ID) SWEAT	DISTRIBUTOR INLET SIZE
116LE	1	1 1/8	7/8
119LE	1	1 1/8	7/8
225LE	2	1 3/8	7/8
232LE	2	1 3/8	1-1/8
240LE	2	1 5/8	1-1/8
348LE	3	1 5/8	1-5/8
356LE	3	1 5/8	1-5/8
471LE	4	2 1/8	1-5/8
113VE	1	1 1/8	7/8
117VE	1	1 1/8	7/8
222VE	2	1 3/8	7/8
228VE	2	1 3/8	1-1/8
234VE	2	1 5/8	1-1/8
339VE	3	1 5/8	1-1/8
350VE	3	1 5/8	1-1/8
459VE	4	1 5/8	1-5/8

**Hot Gas Defrost Models**

MODEL KMP	NO. OF FANS	SUCTION CONNECTION (ID) SWEAT	REVERSE CYCLE DEFROST		3 PIPE DEFROST		HOT GAS DRAIN PAN LOOP CONNECTION (OD) SWEAT
			DISTRIBUTOR INLET SIZE (OD) SWEAT	SIDE PORT CONNECTION (OD) SWEAT	DISTRIBUTOR INLET SIZE (OD) SWEAT	SIDE PORT CONNECTION (OD) SWEAT	
118M^	1	7/8	5/8	1/2	5/8	1/2	7/8
122M^	1	1 1/8	7/8	1/2	7/8	1/2	7/8
228M^	2	1 1/8	7/8	1/2	7/8	1/2	7/8
236M^	2	1 3/8	7/8	1/2	7/8	1/2	7/8
245M^	2	1 3/8	1 1/8	5/8	1 1/8	5/8	7/8
355M^	3	1 5/8	1 1/8	5/8	1 1/8	5/8	1 1/8
368M^	3	1 5/8	1 3/8	7/8	1 3/8	7/8	1 1/8
480M^	4	1 5/8	1 3/8	7/8	1 5/8	7/8	1 3/8
488M^	4	1 5/8	1 3/8	7/8	1 5/8	7/8	1 3/8
116L^	1	1 1/8	7/8	1/2	7/8	1/2	7/8
119L^	1	1 1/8	7/8	1/2	7/8	1/2	7/8
225L^	2	1 3/8	7/8	1/2	1 1/8	5/8	7/8
232L^	2	1 3/8	1 1/8	5/8	1 3/8	7/8	7/8
240L^	2	1 5/8	1 3/8	7/8	1 3/8	7/8	7/8
348L^	3	1 5/8	1 5/8	1 1/8	1 5/8	1 1/8	1 1/8
356L^	3	1 5/8	1 5/8	1 1/8	1 5/8	1 1/8	1 1/8
471L^	4	2 1/8	1 5/8	1 1/8	1 5/8	1 1/8	1 3/8
113V^	1	1 1/8	7/8	1/2	7/8	1/2	7/8
117V^	1	1 1/8	7/8	1/2	7/8	1/2	7/8
222V^	2	1 3/8	7/8	1/2	1 1/8	5/8	7/8
228V^	2	1 3/8	1 1/8	5/8	1 1/8	5/8	7/8
234V^	2	1 5/8	1 3/8	7/8	1 3/8	7/8	7/8
339V^	3	1 5/8	1 1/8	5/8	1 3/8	7/8	1 1/8
350V^	3	1 5/8	1 3/8	7/8	1 5/8	7/8	1 1/8
459V^	4	1 5/8	1 5/8	1 1/8	1 5/8	1 1/8	1 3/8

^ = T, H, G, or R. Refer to Nomenclature for details

AIR DEFROST		
MODEL KMP	SHIPPING WEIGHT	
	LB.	(kg.)
118MA	154	(70)
122MA	161	(73)
228MA	224	(102)
236MA	240	(109)
245MA	254	(115)
355MA	326	(148)
368MA	349	(158)
480MA	414	(188)
488MA	433	(196)

ELECTRIC DEFROST				
MODEL KMP	SHIPPING WEIGHT			
	LB.	(kg.)		
118ME	163	(74)		
122ME	171	(77)		
228ME	241	(109)		
236ME	257	(116)		
245ME	270	(123)		
355ME	349	(158)		
368ME	372	(169)		
480ME	441	(200)		
488ME	460	(209)		
116LE	164	(74)		
119LE	171	(78)		
225LE	243	(110)		
232LE	257	(117)		
240LE	273	(124)		
348LE	352	(160)		
356LE	377	(171)		
471LE	443	(201)		
113VE	160	(73)		
117VE	166	(75)		
222VE	238	(108)		
228VE	250	(113)		
234VE	263	(119)		
339VE	346	(157)		
350VE	362	(164)		
459VE	425	(193)		

HOT GAS DEFROST											
WITH HOT GAS LOOP						WITH ELECTRIC HEATER PAN					
MODEL KMP		SHIPPING WEIGHT				MODEL KMP		SHIPPING WEIGHT			
		LB.	(kg.)					LB.	(kg.)		
118MH	118MR	160	(72)			118MG	118MT	156	(71)		
122MH	122MR	168	(76)			122MG	122MT	164	(74)		
228MH	228MR	239	(108)			228MG	228MT	228	(104)		
236MH	236MR	255	(116)			236MG	236MT	244	(111)		
245MH	245MR	269	(122)			245MG	245MT	258	(117)		
355MH	355MR	353	(160)			355MG	355MT	332	(150)		
368MH	368MR	376	(170)			368MG	368MT	355	(161)		
480MH	480MR	453	(205)			480MG	480MT	421	(191)		
488MH	488MR	472	(214)			488MG	488MT	440	(200)		
116LH	116LR	161	(73)			116LG	116LT	157	(71)		
119LH	119LR	168	(76)			119LG	119LT	164	(75)		
225LH	225LR	241	(109)			225LG	225LT	230	(104)		
232LH	232LR	256	(116)			232LG	232LT	245	(111)		
240LH	240LR	272	(123)			240LG	240LT	261	(119)		
348LH	348LR	356	(162)			348LG	348LT	335	(152)		
356LH	356LR	382	(173)			356LG	356LT	360	(164)		
471LH	471LR	455	(206)			471LG	471LT	423	(192)		
113VH	113VR	157	(71)			113VG	113VT	153	(70)		
117VH	117VR	163	(74)			117VG	117VT	160	(72)		
222VH	222VR	236	(107)			222VG	222VT	226	(102)		
228VH	228VR	249	(113)			228VG	228VT	238	(108)		
234VH	234VR	262	(119)			234VG	234VT	252	(114)		
339VH	339VR	350	(159)			339VG	339VT	329	(149)		
350VH	350VR	367	(166)			350VG	350VT	346	(157)		
459VH	459VR	438	(198)			459VG	459VT	406	(184)		

**Medium Temperature  
Air and Electric Defrost Models**

MODEL KMP	ALL REFRIGERANTS
118M#-S2A	J1-1/2
122M#-S2A	J2
228M#-S2A	J2-1/2
236M#-S2A	G3
245M#-S2A	E4
355M#-S2A	E5
368M#-S2A	E6
480M#-S2A	E10
488M#-S2A	E12

# = A or E. Refer to Nomenclature for details

**Low Temperature  
Electric Defrost Models**

MODEL KMP	ALL REFRIGERANTS
116LE-S2A	G2-1/2
119LE-S2A	G3
225LE-S2A	G4
232LE-S2A	E5
240LE-S2A	E6
348LE-S2A	A8
356LE-S2A	A10
471LE-S2A	A12
113VE-S2A	G2-1/2
117VE-S2A	G2-1/2
222VE-S2A	G3
228VE-S2A	E4
234VE-S2A	E5
339VE-S2A	E6
350VE-S2A	E8
459VE-S2A	A10

**Medium Temperature  
3 Pipe Defrost Models**

MODEL KMP		R404A R507	R448A R407A R407C R22
118MT	118MH	J-1 1/2	J-1
122MT	122MH	G-2	G-1 1/2
228MT	228MH	G-2 1/2	G-1 1/2
236MT	236MH	G-3	G-2
245MT	245MH	E-4	E-2-1/2
355MT	355MH	E-5	E-3
368MT	368MH	C-6	C-4
480MT	480MH	C-8	C-5
488MT	488MH	C-10	C-5

For R449A, use R448A data.

**Medium Temperature  
Reverse Cycle Defrost Models**

MODEL KMP		R404A R507	R448A R407A R407C R22
118MG	118MR	J-1 1/2	J-1
122MG	122MR	G-2	G-1 1/2
228MG	228MR	G-2 1/2	G-1 1/2
236MG	236MR	G-3	G-2
245MG	245MR	E-4	E-2-1/2
355MG	355MR	E-5	E-3
368MG	368MR	C-6	C-4
480MG	480MR	A-8	C-5
488MG	488MR	A-10	C-5

For R449A, use R448A data.

**Low Temperature  
3 Pipe Defrost Models**

MODEL KMP			R448A R407A R404A R507	MODEL KMP			R448A R407A R404A R507
116LT	116LH	G-2-1/2		113VT	113VH	G-2	
119LT	119LH	G-3		117VT	117VH	G-2-1/2	
225LT	225LH	G-4		222VT	222VH	G-3	
232LT	232LH	E-5		228VT	228VH	E-4	
240LT	240LH	C-6		234VT	234VH	C-5	
348LT	348LH	A-8		339VT	339VH	E-6	
356LT	356LH	A-10		350VT	350VH	C-8	
471LT	471LH	A-12		459VT	459VH	A-10	

For R449A, use R448A data.

**Low Temperature  
Reverse Cycle Defrost Models**

MODEL KMP			R448A R407A R404A R507	MODEL KMP			R448A R407A R404A R507
116LG	116LR	G-2-1/2		113VG	113VR	G-2	
119LG	119LR	G-3		117VG	117VR	G-2-1/2	
225LG	225LR	E-4		222VG	222VR	E-3	
232LG	232LR	C-5		228VG	228VR	E-4	
240LG	240LR	C-6		234VG	234VR	C-5	
348LG	348LR	A-8		339VG	339VR	C-6	
356LG	356LR	A-10		350VG	350VR	A-8	
471LG	471LR	A-12		459VG	459VR	A-10	

For R449A, use R448A data.

**RECOMMENDED EXPANSION  
VALVE SELECTIONS  
MEDIUM TEMPERATURE MODELS**

**SPORLAN\***

MODEL KMP	R404A R507	R448A R407A R407C R22	R134a
118M	SBFSE-B-C	SBFVE-A-C	SBFJE-B-C
122M	SBFSE-B-C	SBFVE-B-C	SBFJE-B-C
228M	SBFSE-C-C	SBFVE-B-C	SJE- 2 1/2-C
236M	SSE-3-C	SBFVE-C-C	SJE- 2 1/2-C
245M	SSE-4-C	SVE-4-C	SJE-3-C
355M	SSE-6-C	SVE-4-C	EBSJE-5-C
368M	EBSSE-6-C	SVE-5-C	SJE-5-C
480M	SSE-7-C	EBSVE-8-C	SJE-6-C
488M	EBSSE-7 1/2-C	SVE-8-C	EBSJE-7-C

\* For R507, refrigerant code for Sporlan expansion valve will be "P" instead of "S". i.e.: "SBFSE" becomes "SBFPE"  
For R449A, use R448A data.

**ALCO**

MODEL KMP	R404A R507	R448A R407A R407C R22	R134a
118M	HFESC - 1-1/4 - SC	HFESC - 1-1/2 - HC	HFESC - 1-1/2 - MC
122M	HFESC - 1-1/2 - SC	HFESC - 2 - HC	HFESC - 1-3/4 - MC
228M	HFESC - 2 - SC	HFESC - 2 - HC	HFESC - 1-3/4 - MC
236M	HFESC - 3-1/2 - SC	HFESC - 2-1/2 - HC	HFESC - 2-1/2 - MC
245M	HFESC - 3-1/2 - SC	HFESC - 3 - HC	HFESC - 4 - MC
355M	HFESC - 3-1/2 - SC	HFESC - 5-1/2 - HC	HFESC - 4 - MC
368M	HFESC - 5 - SC	HFESC - 5-1/2 - HC	HFESC - 6 - MC
480M	HFESC - 7 - SC	HFESC - 5-1/2 - HC	HFESC - 6 - MC
488M	HFESC - 7 - SC	HFESC - 8 - HC	HFESC - 7-1/2 - MC

For R449A, use R448A data.

**DANFOSS**

MODEL KMP	R404A R507	R448A R407A R407C R22	R134a
118M	TUAE-07	TUAE-06	TUAE-07
122M	TUAE-08	TUAE-07	TUAE-08
228M	TUAE-09	TUAE-08	TUAE-09
236M	TUAE-09	TUAE-08	TUAE-09
245M	TCAE-2	TUAE-09	TCAE-2
355M	TCAE-3	TCAE-1	TCAE-3
368M	TDEBS 5.8	TCAE-2	TDEBN 8.5
480M	TDEBS 8.0	TCAE-3	TDEBN 9.6
488M	TDEBS 8.0	TCAE-3	TDEBN 9.6

For R449A, use R448A data.

Above selections based on:

- 1) 100°F (38°C) vapor free liquid entering expansion valve
- 2) 110°F (43°C) Condensing temperature
- 3) 8 -12°F (4.4 -6.7°C) evaporator TD

If correct nozzle is not available, the proper orifice size can be drilled in the field using the following chart	
NOZZLE ORIFICE No.	DRILL SIZE IN.
1/2	.070
3/4	.086
1	.0995
1-1/2	.120
2	.1406
2-1/2	.157
3	.172
4	.199
5	.211
6	.242
8	.266
10	.281

**RECOMMENDED EXPANSION  
VALVE SELECTIONS  
LOW TEMPERATURE MODELS**

**SPORLAN - R407A R448A**

MODEL KMP	0° F (-18° C) EVAP.	-10° F (-23° C) EVAP.	-20° F (-29° C) EVAP.	-30° F (-34° C) EVAP.	-40° F (-40° C) EVAP.
116L	SBFVE-A-C	SBFVE-B-ZP40	SBFVE-B-ZP40	SBFVE-B-ZP40	SBFVE-B-ZP40
119L	SBFVE-B-C	SBFVE-B-ZP40	SBFVE-B-ZP40	SBFVE-B-ZP40	SBFVE-C-ZP40
225L	SVE-3-C	SVE-3-ZP40	SVE-4-ZP40	SVE-4-ZP40	SVE-5-ZP40
232L	SVE-3-C	SVE-4-ZP40	SVE-4-ZP40	SVE-5-ZP40	SVE-8-ZP40
240L	SVE-4-C	SVE-5-ZP40	SVE-5-ZP40	SVE-8-ZP40	SVE-8-ZP40
348L	SVE-4-C	SVE-8-ZP40	SVE-8-ZP40	SVE-10-ZP40	SVE-10-ZP40
356L	SVE-5-C	SVE-8-ZP40	SVE-10-ZP40	SVE-10-ZP40	OVE-15-ZP40
471L	SVE-8-C	SVE-10-ZP40	OVE-15-ZP40	OVE-15-ZP40	OVE-15-ZP40
113V	SBFVE-A-C	SBFVE-A-ZP40	SBFVE-B-ZP40	SBFVE-B-ZP40	SBFVE-B-ZP40
117V	SBFVE-A-C	SBFVE-B-ZP40	SBFVE-B-ZP40	SBFVE-B-ZP40	SBFVE-B-ZP40
222V	SBFVE-B-C	SVE-3-ZP40	SVE-3-ZP40	SVE-4-ZP40	SVE-4-ZP40
228V	SVE-3-C	SVE-4-ZP40	SVE-4-ZP40	SVE-4-ZP40	SVE-5-ZP40
234V	SVE-3-C	SVE-4-ZP40	SVE-5-ZP40	SVE-5-ZP40	SVE-8-ZP40
339V	SVE-4-C	SVE-5-ZP40	SVE-5-ZP40	SVE-8-ZP40	SVE-8-ZP40
350V	SVE-5-C	SVE-8-ZP40	SVE-8-ZP40	SVE-10-ZP40	SVE-10-ZP40
459V	SVE-8-C	SVE-8-ZP40	SVE-10-ZP40	SVE-10-ZP40	OVE-15-ZP40

**SPORLAN - R404A**

MODEL KMP	0° F (-18° C) EVAP.	-10° F (-23° C) EVAP.	-20° F (-29° C) EVAP.	-30° F (-34° C) EVAP.	-40° F (-40° C) EVAP.
116L	SBFSE-B-C	SBFSE-B-ZP	SBFSE-B-ZP	SBFSE-C-ZP	SBFSE-C-ZP
119L	SBFSE-B-C	SBFSE-B-ZP	SBFSE-C-ZP	SBFSE-C-ZP	SBFSE-C-ZP
225L	SSE-3-C	SSE-3-ZP	SSE-3-ZP	SSE-4-ZP	SSE-4-ZP
232L	SSE-4-C	SSE-4-ZP	SSE-4-ZP	SSE-4-ZP	SSE-4-ZP
240L	SSE-4-C	SSE-4-ZP	EBSSE-6-ZP	EBSSE-6-ZP	EBSSE-6-ZP
348L	SSE-6-C	SSE-6-ZP	SSE-6-ZP	SSE-7-ZP	SSE-7-ZP
356L	SSE-7-C	SSE-7-ZP	SSE-7-ZP	OSE-9-ZP	OSE-9-ZP
471L	OSE-9-C	OSE-12-ZP	OSE-12-ZP	OSE-12-ZP	OSE-12-ZP
113V	SBFSE-B-C	SBFSE-B-ZP	SBFSE-B-ZP	SBFSE-B-ZP	SBFSE-B-ZP
117V	SBFSE-B-C	SBFSE-B-ZP	SBFSE-C-ZP	SBFSE-C-ZP	SBFSE-C-ZP
222V	SBFSE-C-C	SBFSE-C-ZP	SBFSE-C-ZP	SBFSE-C-ZP	SBFSE-C-ZP
228V	SSE-3-C	SSE-3-ZP	SSE-3-ZP	SSE-4-ZP	SSE-4-ZP
234V	SSE-4-C	SSE-4-ZP	SSE-4-ZP	SSE-6-ZP	SSE-6-ZP
339V	SSE-4-C	EBSSE-6-ZP	EBSSE-6-ZP	EBSSE-6-ZP	EBSSE-6-ZP
350V	EBSSE-6-C	EBSSE-7-1/2-ZP	EBSSE-7-1/2-ZP	EBSSE-7-1/2-ZP	EBSSE-7-1/2-ZP
459V	SSE-7-C	SSE-7-ZP	SSE-7-ZP	OSE-9-ZP	OSE-9-ZP

\* For R507, refrigerant code for Sporlan expansion valve will be "P" instead of "S" . i.e.: "SBFSE" becomes "SBFPE"

For R449A, use R448A data.

Above selections based on:

- 1) 100°F (38°C) vapor free liquid entering expansion valve
- 2) 110°F (43°C) Condensing temperature
- 3) 8 -12°F (4.4 -6.7°C) evaporator TD



## INSTALLATION

The installation and start-up of evaporators should only be performed by qualified refrigeration mechanics. This equipment should be installed in accordance with all applicable codes, ordinances and local by-laws.

## INSPECTION

Inspect all equipment before unpacking for visible signs of damage or loss. Check shipping list against material received to ensure shipment is complete.

**IMPORTANT:** Remember, you, the consignee, must make any claim necessary against the transportation company. Shipping damage or missing parts, when discovered at the outset, will prevent later unnecessary and costly delays. **If damage or loss during transport is evident, make claim to carrier, as this will be their responsibility, not the manufacturer's.**

Should carton be damaged, but damage to equipment is not obvious, a claim should be filed for "concealed damage" with the carrier.

**IMPORTANT:** The electrical characteristics of the unit should be checked at this time to make sure they correspond to those ordered and to electrical power available at the job site.

Save all shipping papers, tags and instruction sheets for reference by installer and owner.

## APPLICATION

MP evaporators are designed for walk-in cooler, walk-in refrigerated warehouse and food processing plant applications used with a wide variety of refrigerants. For room temperatures above 35°F (2°C) AND evaporating temperatures above 26°F (-3°C), positive defrosting means (with electric or hot gas) may not be required, otherwise, electric defrost or hot gas defrost models should be used. Electric defrost models come with defrost termination and fan delay as standard to control the defrost cycle termination and fan delay, while defrost initiation means (e.g. defrost timer) is not included.

For other types of refrigerant, contact factory.

The coil must not be exposed to any abnormal atmospheric or acidic environments. This may result in corrosion to the cabinet and possible coil failure (leaks). (Consult manufacturer for optional baked on phenolic protective coatings).

## LOCATION

The unit location in the room should be selected to ensure uniform air distribution throughout the entire space to be refrigerated. Be sure that the product does not obstruct the free circulation of air. Allow a minimum of 24" clearance at each end. Do not locate evaporators over doors. Consideration should be given to the coil location in order to minimize the piping run length to the condensing unit and floor drain.

## EXPANSION VALVE (TXV) SELECTION

All units require the use of an **externally equalized** expansion valve. (A 1/4" (6 mm) O.D. equalizer line has been provided on the coil) TX valves should **not** be selected strictly by their nominal ton rating. (This rating is

based at a specific pressure differential and entering liquid temperature). Since applications will differ it is suggested the following selection procedure be followed.

1. Determine actual evaporator capacity. The nominal rating is based at 10°F T.D. (5.6°C) (Entering Air Temp. minus Evap. Temp.) Note that a higher / lower operating T.D. will increase / decrease this capacity rating by their direct ratio within a range of 8 to 12°F (4.4 to 8.3°C) T.D.
2. Determine the pressure drop across the valve by subtracting the evaporating pressure and distributor pressure drop from the high side liquid pressure. The distributor pressure drop is typically in the range of 20 to 35 psig (1.4 to 2.4 bar) depending on the type of refrigerant and operating conditions.
3. Estimate entering liquid temperature. Temperatures lower than 100°F (38 °C) increase valve capacity ratings. Refer to valve manufacturer's specs for details.
4. Select valve from the valve manufacturer selection charts or software for the appropriate refrigerant, evaporating temp and pressure drop.

For best performance, the outlet of the expansion valve should be installed directly to the distributor body. If this is not possible, a straight tube up to 12 inches may be used for the connection.

Locate the expansion valve bulb on a horizontal length of suction line preferably 3 to 6 inches from the suction header. Locate the bulb at 4 or 8 clock position and insulate with a waterproof type of insulation. Clamp the bulb to ensure 100% contact of the bulb with the suction line.

Ensure appropriate nozzle has been installed in the distributor before installing valve. After following the manufacturer's installation instructions and after the room has reached the desired temperature the valve superheat should be checked. This will confirm that the evaporator is operating properly and performing to maximum efficiency. The superheat should be around 60 to 80% of T.D. Too high or low a superheat will result in unsatisfactory system performance and possible compressor problems.

## NOZZLE INSTALLATION

For common applications (Medium temp. R404A/R22/R407A/R448A 8 to 12°F (4.4 to 6.7°C) T.D.); (Low temp. R404A/R407A/R448A 8 to 12°F (4.4 to 6.7°C) T.D.) the nozzle for all models has been factory installed. For other applications, refer to nozzle manufacturer's selection guide. To replace a nozzle, the nozzle retainer clip (in distributor) must be removed before inserting nozzle. Re-install clip ensuring nozzle is properly in place. A small nozzle can be drilled larger using the drill size listed in table on page 31. Ensure the hole must be accurately centered and smooth. A lathe is preferred for the drilling.

**MOUNTING**

Refer to dimensional drawing for recommended mounting arrangements. Ensure adequate clearance is provided behind the coil as well as each end. The evaporators may be mounted flush with ceiling with bolts, or hanging down with rod hangers. When using rod hangers, allow adequate space between the top of the unit and the ceiling for cleaning to comply with NSF Standard 7.

**Ensure that the ceiling is level since the drain pan has been sloped for drainage during the defrost cycle.**

**DRAIN LINE**

The drain line should be run from the drain connection, sloping at least 1" (25 mm) per foot and should have the size at least as large as the drain connection. A trap in a warm area outside the room must be provided to allow proper draining through the tubing. Connection should be made to proper drainage facilities that comply with local regulations.

To prevent freeze-up when the temperature of the refrigerated space is 35°F (2 °C) or lower, the drain line should be heated along its run inside the cold room. The heated drain line should be insulated. It is recommended that the heater be energized at all times. A heat input of 20 watts per foot in a 28°F (-2°C) room and 30 watts per foot for -20°F (-29°C) rooms, is satisfactory. Drain line heaters are not required for constant room temperature above 35°F (2°C).

Always trap evaporator drain line individually to prevent vapor migration.

**Ensure that the drain line has sufficient slope for proper drainage (prevention of ice build up/blockage in pan).**

**PIPING**

Refrigeration grade piping must be used for all field refrigeration piping. Refrigerant line sizes are important and **may not** be the same size as the coil connections. Consult ASHRAE handbook or other similar reference book for proper line sizing.

Refrigerant piping and control system should be designed to prevent possible liquid slugging (from oil or refrigerant) of the compressors on start-up after the defrost cycle. Also, it should prevent oil logging and minimize refrigerant pressure drop.

For hot gas models, see pages 38 to 39 for recommended piping.

**WIRING**

Wire system in accordance with governing standards and local codes. See data and wiring diagrams on pages 4 to 29 for typical wiring arrangement. Electrical wiring is to be sized in accordance with minimum circuit ampacity rating (MCA). Size fuses used must not exceed the Maximum Fuse Size ratings.

For ease of identifying the proper wiring terminal, unit wiring is color coded and terminal block connections are identified.

When **fan delay thermostats** (combination fan delay and defrost termination) are installed, on start-up, the fans do not operate until the coil temperature is reduced to approximately 25°F (-4°C). It is normal for the fans to cycle a few times until the room temperature is brought down. At higher evaporating temperatures this control may not close and therefore should either be by-passed temporarily or replaced with an adjustable type. (set for a higher temperature cut-in point).

**MAINTENANCE**

The unit should be periodically inspected for any dirt or ice build-up on the fin surface and cleaned if necessary with a soft whisk or brush. Also ensure coils inner (and outer) drain pans do not have any ice build-up from improper defrost operation. When replacing heater elements first remove heater retainer brackets and heater clips.

**SYSTEM CHECK****Before Start-Up:**

1. All wiring should be in accordance with local codes.
2. Refrigerant lines should be properly sized.
3. All systems preferably include a liquid line solenoid valve at immediately up stream of the expansion valve.
4. Thorough evacuation and dehydration has been performed.
5. The suction, discharge, and receiver service valves must be open.
6. The system preferably include a liquid line filter drier moisture indicator and suction filter.
7. Pour enough water into the drain pan to allow a good check on drainage and seal the trap.

**After Start-Up:**

1. Check the oil level to be sure the oil charge is correct.
2. On initial start up the fans do not start until coil temperature is pulled down to approximately 25°F (-4°C) on the coil. Also, it is normal for the fan to cycle a few times until the room temperature is pulled down.
3. If necessary, temporarily by-pass fan delay control (to run fans until room temp is lowered).
4. Be sure that the expansion valve is properly set to provide the correct amount of superheat.
5. After the box temperature is close to reaching the desired temperature, the evaporator superheat must be checked and adjustment made if necessary. In general, evaporators running with a TD of 10°F (5.6°C) should have a superheat reading of 6° to 8°F (3.3°C to 4.4°C). For evaporators with another T.D., the general rule is that the superheat should be around 60 to 80% of T.D.
6. Heavy moisture loads are usually encountered when starting the system for the first time. This may cause a rapid build-up of frost on the evaporator. During the initial pull down, we suggest that the frost build-up be watched and defrosted manually as required.
7. Observe that the system goes through at least one complete DEFROST CYCLE.

Refer to Nomenclature for details

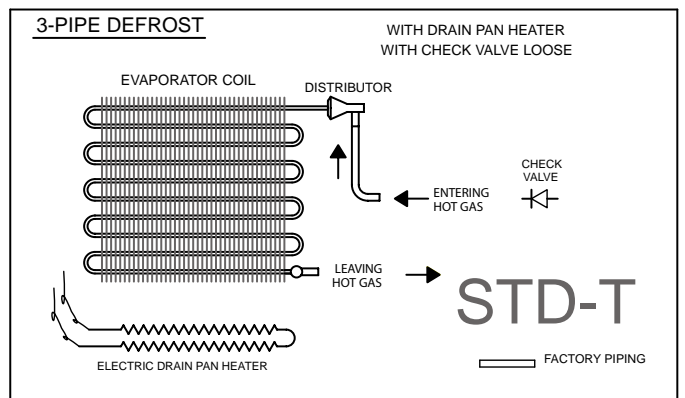
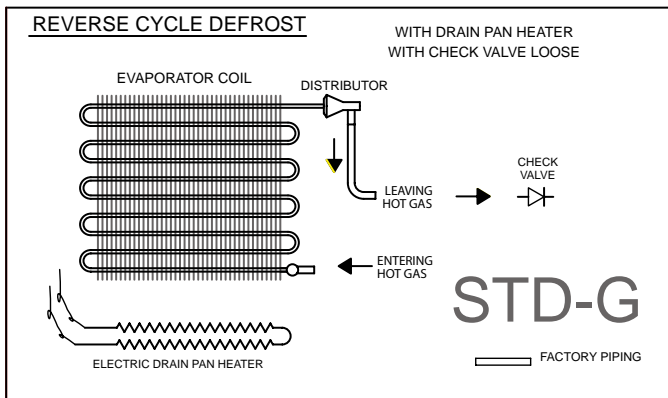
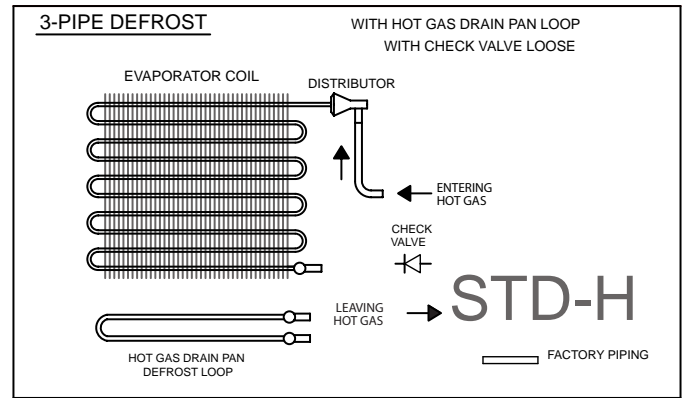
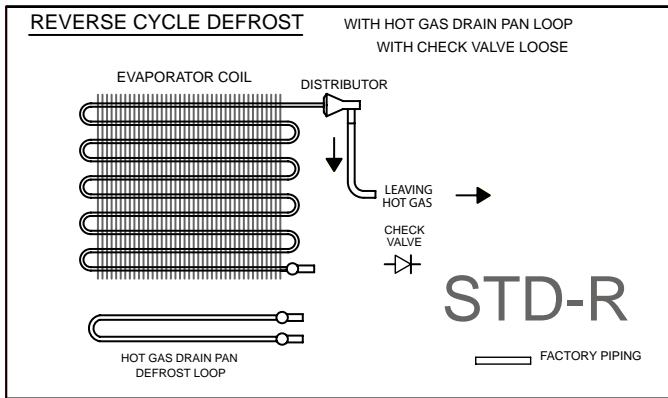

**Standard Offering: All Models**

Check Valve is included with the coil shipped loose as it is a must have component for system operation.

**Check Valve & TXV - See next page (OPT 1)**

When a TXV is ordered with a HG defrost coil: Its only option will be **Factory Installed**. The bypass check valve will be **factory installed** as well as part of the same option.

- **Reverse Cycle PanHeater (G Models)** when ordered with TXV & Check Valve:
  - TXV, Check Valve and bypass Tee are factory installed
- **Reverse Cycle PanLoop (R Models)** when ordered with TXV & Check Valve:
  - TXV, Check Valve and bypass Tee are factory installed
- **3-Pipe PanHeater (T Models)** when ordered with TXV & Check Valve:
  - TXV and Check Valve are factory installed
- **3-Pipe PanLoop (H Models)** when ordered with TXV & Check Valve:
  - TXV and Check Valve are factory installed

Refer to Nomenclature for details

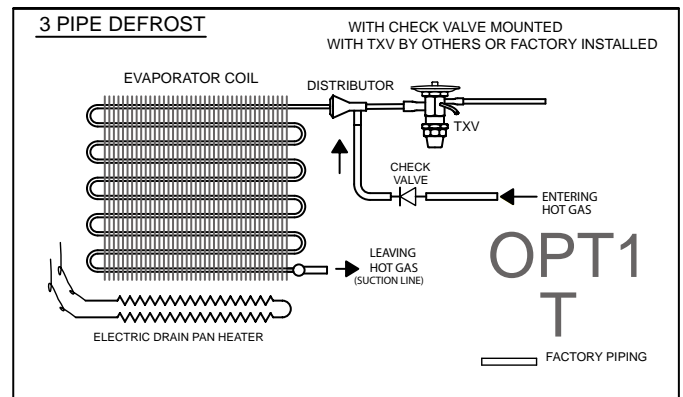
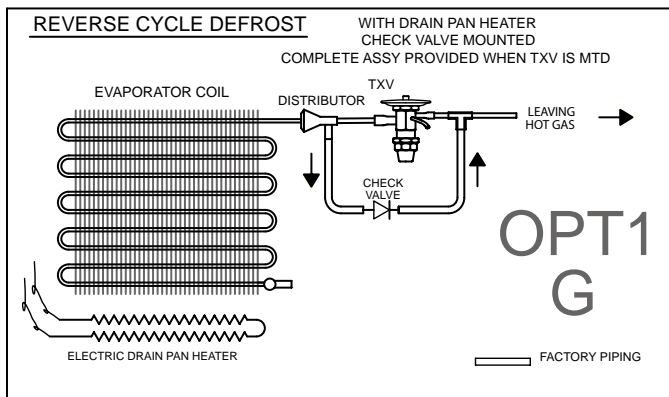
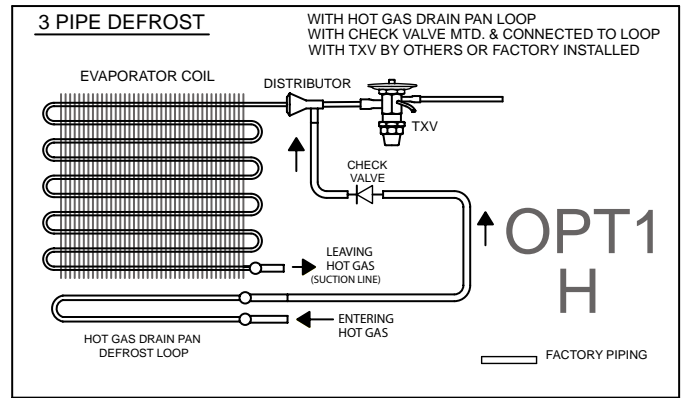
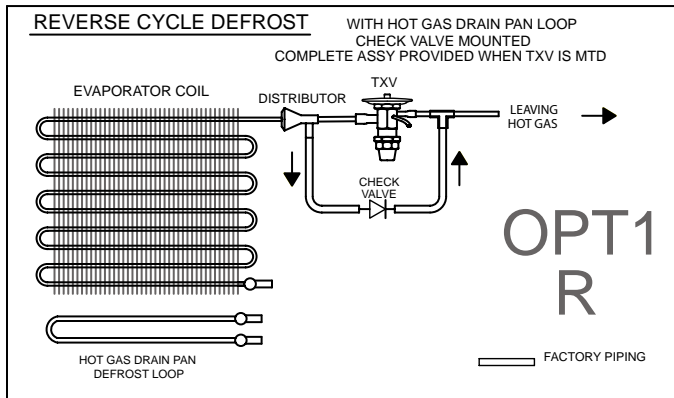

## Drain pan Loop Kit - See below (OPT 2)

Drain pan loop kit is an assembly that is fully assembled and shipped loose for field installation outside the cabinet. Two check valves are included, depending on the model size, one or both are factory installed.

- **Reverse Cycle PanLoop (R Models)** when ordered with TXV & Check Valve:
  - Suction line piping shipped as a pre-piped assembly for field installation

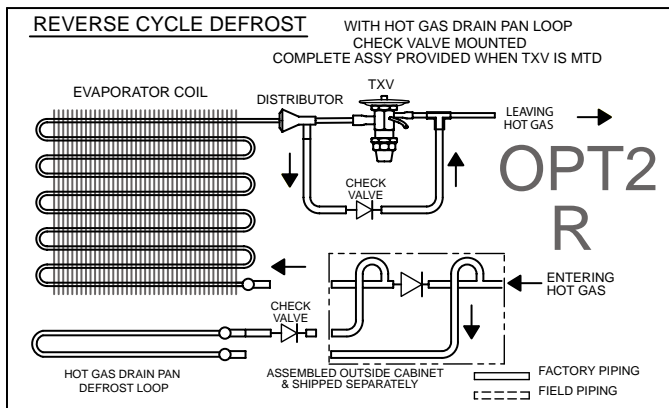

## Solenoid Valve

Solenoid valves are available as a shipped loose item due to limited space inside the cabinet

MODEL KMP	NO. OF FANS	CAPACITY * - 15 USGPM (.095 L/S), 3/8" TUBING							CAPACITY * - 40 USGPM (.25 L/S), 1/2" TUBING						
		AIR FLOW		BTU/H	(WATTS)	P.D. (FT. H <sub>2</sub> O)	P.D. (kPa)	CONN. SIZE (IN/OUT)	AIR FLOW		BTU/H	(WATTS)	P.D. (FT. H <sub>2</sub> O)	P.D. (kPa)	CONN. SIZE (IN/ OUT)
		CFM	(L/S)						CFM	(L/S)					
<b>118W</b>	1	3430	(1620)	8980	(2630)	4.8	(14.3)	1 3/8	3150	(1486)	11100	(3250)	7.8	(23.3)	1 5/8
<b>122W</b>	1	3240	(1530)	10400	(3050)	2.8	(8.4)	1 3/8	2990	(1411)	12700	(3720)	4.6	(13.7)	1 5/8
<b>236W</b>	2	6870	(3240)	15400	(4510)	8.1	(24.2)	1 3/8	6300	(2973)	21700	(6360)	13	(37.4)	1 5/8
<b>245W</b>	2	6480	(3060)	18100	(5300)	4.8	(14.3)	1 3/8	5980	(2822)	22800	(6680)	7.4	(22.1)	1 5/8
<b>355W</b>	3	10300	(4860)	20700	(6060)	11	(33.2)	1 3/8	9480	(4474)	31900	(9340)	17	(51.7)	1 5/8
<b>368W</b>	3	9720	(4590)	24200	(7090)	6.7	(20.0)	1 3/8	8940	(4219)	31600	(9260)	10	(31.1)	1 5/8
<b>480W</b>	4	13000	(6140)	27700	(8110)	7.6	(22.7)	1 3/8	11990	(5658)	37500	(11000)	12	(35.3)	1 5/8

The above capacities were rated based on 30% Propylene Glycol, 25°F (-4°C) glycol entering temperature and 35°F (2°C) air entering temperature with glycol flow rate listed. For all other conditions, please use "Pi-Coil" software (contact factory).

System	
Model Number	Date of Start-Up
Serial Number	Service Contractor
Refrigerant	Phone
Electrical Supply	E-mail

**PRODUCT SUPPORT**

*web:* [k-rp.com/kmp](http://k-rp.com/kmp)  
*email:* [evaps@k-rp.com](mailto:evaps@k-rp.com)  
*call:* 1-844-893-3222 x520

**TROUBLESHOOTING**

*email:* [troubleshooting@k-rp.com](mailto:troubleshooting@k-rp.com)  
*call:* 1-844-893-3222 x529

**SERVICE PARTS**

*web:* [k-rp.com/parts](http://k-rp.com/parts)  
*email:* [parts@k-rp.com](mailto:parts@k-rp.com)  
*call:* 1-844-893-3222 x501

**WARRANTY**

*web:* [k-rp.com/warranty](http://k-rp.com/warranty)  
*email:* [warranty@k-rp.com](mailto:warranty@k-rp.com)  
*call:* 1-844-893-3222 x501

**ORDERS**

*email:* [orders@k-rp.com](mailto:orders@k-rp.com)  
*call:* 1-844-893-3222 x501

**SHIPPING**

*email:* [shipping@k-rp.com](mailto:shipping@k-rp.com)  
*call:* 1-844-893-3222 x503

# “AS BUILT” SERVICE PARTS LIST

Service Parts List  
Label  
To Be Attached  
*HERE*



NATIONAL REFRIGERATION &  
AIR CONDITIONING CANADA CORP.  
159 ROY BLVD., BRANTFORD, ON, N3R 7K1



1-800-463-9517 (519) 751-0444  
www.k-rp.com info@k-rp.com fax: (519) 753-1140

Due to the manufacturer's policy of continuous product improvement, we reserve the right to make changes without notice.