

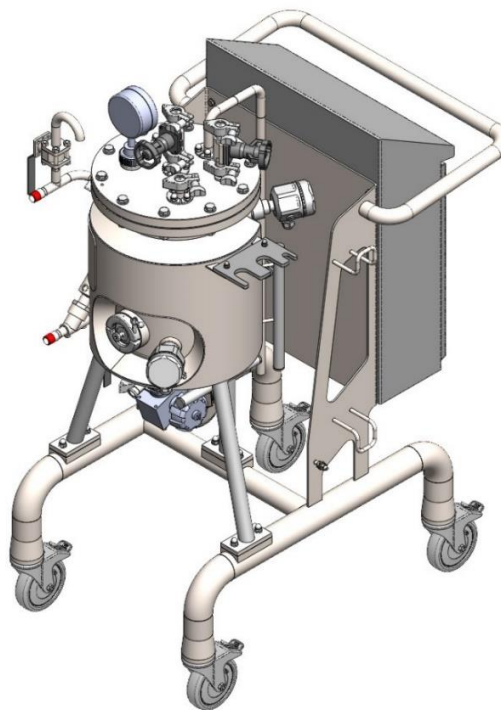

TRANSLATION OF THE ORIGINAL INSTRUCTIONS

for pressure equipment to PED 2014/68/EU
Machinery Directive 2006/42/EC and ATEX 2014/34/EU

Vessel 20L



Manufactured for : x
Drawing number : 3598
Year of manufacture : 2021



READ THESE INSTRUCTIONS CAREFULLY BEFORE USE

KEEP THEM TO HAND FOR REFERENCE

Table of Contents

	Page
1. About this document	1-1
1.1 Limitation of liability	1-1
1.2 Purpose of this document	1-1
1.3 Copyright and warranty	1-2
1.4 Project data	1-3
1.5 CE Marking	1-3
1.6 For completion by the customer	1-3
2. Safety information	2-1
2.1 Symbols	2-1
2.1.1 Warning notices	2-2
2.1.2 Electrotechnical warning signs and terms	2-3
2.1.3 Rules	2-3
2.1.4 Prohibitions	2-4
2.1.5 Hazardous substances	2-4
2.2 Using the vessel safely	2-5
2.3 Staff training	2-6
2.4 Plant owner's organisational measures	2-7
2.5 Planning and installation	2-8
2.6 Safety devices	2-8
2.7 Faults	2-9
2.8 General safety information	2-11
2.8.1 Pneumatic components	2-11
2.8.2 Electrics	2-13
2.8.3 Chemicals	2-14
2.8.4 Noise	2-14
2.9 Specific safety information	2-15
2.9.1 Leaking fluids due to a fault	2-15
2.9.2 Inspection/operational access points	2-15
2.9.3 Reaching/climbing into the vessel	2-16
2.9.4 Vessel heating (OPTION)	2-16
2.9.5 Cleaning the vessel	2-17
2.10 Design or structural modifications to vessels	2-17
2.11 Fighting a vessel fire	2-18
2.11.1 Fire fighting on vessels with electrical equipment	2-18
2.11.2 Fighting external fires	2-18
3. Declaration of conformity (PED/MD/ATEX)	3-19
4. Information on ATEX requirements	4-20

5.	Product description	5-21
5.1	Intended purpose	5-21
5.2	Scope of use	5-21
5.3	Compatibility of materials	5-21
5.4	Technical data (basic data)	5-22
5.5	Airborne noise emissions	5-23
5.6	Vessel drawing	5-23
5.7	Electrical data	5-23
5.8	Vessel features	5-23
5.9	Add-on components	5-24
6.	Transport	6-1
6.1	Scope of delivery	6-1
6.2	Stipulations regarding staff involved in transport	6-1
6.3	Transport	6-1
6.4	Storage	6-2
7.	Assembly, set-up and acceptance	7-1
7.1	Assembly and set-up	7-1
7.2	Overview of connections	7-1
	7.2.1 Connecting the power supplies	7-2
7.3	Acceptance	7-4
8.	Operating the unit	8-1
8.1	Commissioning requirements	8-1
8.2	Operating the unit	8-1
8.3	Earthing	8-1
8.4	Add-on components	8-1
8.5	Filling/emptying	8-2
8.6	Moving the vessel	8-2
9.	Decommissioning	9-1
10.	Cleaning	10-3
11.	Repairs	11-4
11.1	Maintenance	11-6
11.2	Maintenance intervals	11-7
11.3	Recurring inspections	11-7
11.4	Ordering spare parts	11-8
12.	Environmental protection	12-1
13.	Appendix	13-1
13.1	Declaration of knowledge by assigned staff	13-1

1. About this document

1.1 Limitation of liability

Before carrying out any work, operators and anyone working for the user and assigned by an authorised person to set up, commission, operate, maintain or repair the vessel must carefully read and take account of these instructions and the separate instructions of the third-party manufacturers.

RAFF+GRUND GmbH accepts no liability for damage and malfunctions caused by failing to follow the instructions.

1.2 Purpose of this document

These instructions are designed to help you use the vessel as intended. They include important information on how to use the vessel safely, appropriately, and cost-effectively. Following the instructions helps prevent hazards, repair costs and downtime as well as increasing the machine's reliability and extending its service life.



Staff information requirements

All staff who will be using this vessel must first read and understand the instructions, in particular section 2: → 'Safety information'.



Plant owners can use the appended template for staff sign-off.



Where to keep the instructions

Please keep the instructions with the vessel so that they are available to staff at all times.



Follow the instructions, the mandatory accident prevention regulations applicable at the site of use and the accepted principles of safe, professional work practices.

1.3 Copyright and warranty

These instructions and their accompanying documents are protected by copyright. They are entrusted to customers and plant owners who use our products.

In accordance with our General Terms and Conditions of Sale and Supply, this machine is under warranty for 12 months from its acceptance/commissioning date.

Rework, repairs or modifications by persons not authorised by the manufacturer will void all warranty claims. The instructions are an integral part of the delivery package and must be handed over to the new owner if you re-sell the vessel.

The warranty is limited to the repair or replacement of faulty parts including any replacement costs. The warranty excludes all consequential damages caused by malfunctions. Wear parts are excluded from the warranty.

Warranty claims will only be accepted if we can verify that the maintenance specified by the manufacturer in the instructions has been carried out and complied with. Please create and maintain a maintenance log.

The warranty excludes damage attributable to inadequate maintenance, the use of unsuitable fluids and operating materials, incorrect operation and third-party responsibility.

Warranty claims must be submitted in writing.

Warranty and liability claim for personal injury and damage to property are excluded if attributable to one or more of the following:

- Abnormal use of the vessel.
- Incorrectly assembling, commissioning, operating, and maintaining the vessel.
- Operating the vessel with defective, incorrectly fitted, or inoperable safety and protective devices.
- Failing to follow the information in the instructions concerning the transport, storage, assembly, commissioning, operation, maintenance, and set-up of the process unit.
- Unauthorised modifications to the vessel.
- Failing to monitor vessel wear parts properly.
- Carrying out repairs incorrectly.
- Emergencies caused by foreign objects or force majeure.



Machine damage

If you identify a safety-related malfunction, please contact us immediately:

RAFF+GRUND GmbH
Max-Eyth-Str. 9-13
71691 Freiberg am Neckar, Germany
Tel.: +49 71 41 2771-0 (switchboard)
Email: info@raff-grund.de

We reserve the right to make improvements to the technical specification.

1.4 Project data

Manufacturer or authorised representative	RAFF+GRUND GmbH Max-Eyth-Str. 9-13 71691 Freiberg am Neckar, Germany
Machine designation	Vessel 20L
Drawing number	3598
Year of manufacture	2021
Service contact	+49 71 41 2771-0 (switchboard) info@raff-grund.de
Document version	V2.1
Created on	30.04.2021
Last changed on	12.08.2021

1.5 CE Marking

The type plate bearing the CE Marking is located on the vessel shell, indicating the manufacturer, year of manufacture and serial number.

1.6 For completion by the customer

Inventory number:

Site:

2. Safety information

2.1 Symbols

The following symbols on the unit and on all safety information in these instructions indicate specific personal, material or environmental hazards.

Observe these notices and take particular care in the situations concerned. Ensure that other users are aware of all safety information.



This signal word indicates a high-risk hazard that could kill or seriously injure someone if not avoided.



This signal word indicates a medium-risk hazard that could seriously injure and possibly kill someone if not avoided.



This signal word indicates a low-risk hazard that could cause minor or moderate injuries if not avoided.



This signal word indicates a hazard that could cause material (property) damage or environmental harm if not avoided.



Information

This tells you about important interdependencies that you should bear in mind when operating the unit and that make it easier to operate.



Assembly/maintenance/basic requirements

Provides information on individual work steps during machine assembly and maintenance and indicates the basic requirements necessary for machine operation.



Function

Explains a machine function or a workflow sequence.



Setting

Refers to important information about setting operating parameters, and basic requirements that must be in place to operate the machine.



2.1.1 Warning notices



General warning sign



Hot surface warning



Hand injury warning



Crush hazard warning



Warning about standing under suspended loads



Warning about obstructions on the ground or floor



Fall hazard



Corrosive substances

2.1.2 Electrotechnical warning signs and terms



Dangerous electrical voltage warning



Protective Earth (PE)



PE/PE connection

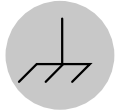

Earth

2.1.3 Rules



General rule sign



Observe user instructions



Use hearing protection



Use eye protection



Use protective footwear



Use protective gloves



Use protective clothing



Use protective headgear

2.1.4 Prohibitions



Do not dispose of materials as standard waste

2.1.5 Hazardous substances



Explosive



Highly flammable



Oxidising



Compressed gases



Corrosive/irritant



Highly toxic



Acute toxicity



Risk to health



Environmental hazard

2.2 Using the vessel safely

The vessel is designed and manufactured in line with the latest engineering and safety standards. Nevertheless, it may pose a risk to people and property if ...

- ... it is used abnormally.
- ... it is operated by untrained staff.
- ... it is incorrectly modified or converted.
- ... the safety information is not followed.

It is only safe when operated correctly by trained staff. Do not use the vessel unless it is in perfect working order, you are aware of the hazards and you are following the safety procedures!

Certain work on the vessel and its accessories must only be done by suitably qualified staff (competent persons). Qualified staff are those who, based on their training, knowledge and experience, are authorised by the managers in charge and are able to identify and avoid potential hazards.

Malfunctions and defects (e.g. missing protective devices such as covers or panels) that could affect safety must be rectified immediately. The vessel must then be left powered down until it can be used again correctly.

It is vital that you observe the safety information below. It is a critical and indispensable part of the user documentation. Failing to adhere to this information may void warranty claims.

In the safety interests of all concerned, we recommend that you create a machine companion book, assigned to the vessel, in which you log all installation, maintenance, fault and repair incidents, training and instruction, and incidents of note.

The vessel may pose risks, especially if you fail to follow the safety regulations. If the person in charge of operating the vessel does not understand the instructions, that person has an obligation to contact the manufacturer and obtain clarification as necessary.

Do not use the vessel unless it is in perfect working order. All intended protective devices must be in place and working properly. Observe the notices and warning signs affixed to the vessel.

Regardless of the information in these instructions, the applicable national safety and accident-prevention regulations apply along with other generally accepted occupational safety and health regulations.



Statutory safety inspections

Please refer to the applicable national requirements on conducting safety inspections.

2.3 Staff training

We recommend that plant owners write their own in-house instructions for their employees explaining how to use the machine in compliance with national requirements and train each relevant member of staff.

- There should be a designated person in charge of the machine, with the required specialist knowledge and training.
- The person in charge of the machine is also responsible for instructing operators.

The vessel must only be operated by qualified, trained and/or instructed staff. Operating, maintenance, inspection, cleaning and assembly staff must provide proof of the corresponding training.

Operators

- The vessel must only be operated by qualified, trained and/or instructed staff.
- Operator training has been based on these instructions. Operators have been given safety training on the hazards relevant to their work.

Qualified staff – e.g. fitter/maintenance staff (mechanical/electrical)

This person is a 'competent person':

- The competent person has completed vocational training that allows their professional knowledge to be verified. This verification is based on a certificate for a vocational qualification or comparable qualification.
- The competent person has professional experience, i.e. is required to have worked with similar equipment for a verified length of time and is sufficiently familiar with its functional and operational principles.
- The competent person has sufficient knowledge of the directives and standards relevant to and required for their work.
- The competent person's training has been based on these instructions. Operators have been given safety training on the hazards relevant to their work.

Cleaning staff

- Cleaning staff must know how to handle and use cleaning equipment correctly.
- Cleaning staff must be familiar with the cleaning agents used, including the content of safety data sheets, where available, for these cleaning agents and their hazardous substances.
- Cleaning staff training has been based on these instructions. Cleaning staff have been given safety training on the hazards relevant to their work.

Staff

- All staff



Important

Induction and training

The plant owner has obtained written confirmation that its **staff** have received induction or training which allows them to safely operate, maintain and repair the machine.



A blank form for copying and completion is provided for this purpose:

→ 13.1 Declaration of knowledge by assigned staff

2.4 Plant owner's organisational measures

The plant owner must ensure ...

- compliance with the manufacturer's requirements for commissioning, operation and repair as described in the instructions.
- that the vessel is appropriately operated, inspected and maintained and that work responsibilities and skills are clearly set out.
- that staff are given the relevant training to handle the vessel and its safety devices correctly.
- that damaged or removed notices and warning signs are replaced promptly.
- that the intended protective devices are in place and working properly.

2.5 Planning and installation



Planning, transport, assembly, installation, programming, commissioning, maintenance, repairs, decommissioning, disassembly and other work or interventions in the machine area must be done by **qualified staff** and checked by the manager(s) in charge.

Please adhere to the following in particular:

- The technical data and specifications about permitted use of the vessel and its accessories.
- Skilled use of tools and exchangeable fittings.
- Particular hazards when using the vessel in custom conditions that are not specifically mentioned in the instructions but are not explicitly forbidden.

2.6 Safety devices

The vessel is designed with integrated safety and protective devices. Do not commission or operate the vessel if any such devices are removed, bypassed or not working properly.

 Danger	<p>Hazards or hazardous movements due to manipulated safety functions</p> <p>Operating the vessel while its safety functions are not working may cause serious and possibly disabling injuries, and in the worst case, can kill someone.</p> <ul style="list-style-type: none">• Do not operate the vessel until qualified staff have ensured that the protective devices are working.• Do not use the vessel unless all required protective devices are fully installed and activated. Do not bypass or deactivate these safety devices.	 
---	--	---

At least once a year, carry out a safety review and document the findings in writing.

Safety reviews must be carried out by **qualified staff** (competent persons) whose specialist training and experience provides them with sufficient knowledge of the design and function of the vessel for inspection and who are familiar enough with the applicable safety regulations to assess the occupational safety of the machine or unit.

The vessel's protective devices are designed to minimise the risk to operators who are using the vessel for its intended purpose. Reasonably foreseeable misuse is also taken into account.

However, due to the workflows involved, some points and parts on the vessel cannot be fully safeguarded without adversely affecting their function, operability and repair. This means that despite built-in safety measures and installed protective devices, there is still a residual risk ...

- ... of danger to the life and health of users or third parties.
- ... of damaging the tool or other objects.
- ... of inefficient use of the vessel.

To minimise these residual risks sufficiently, it is vital that the plant owner's **staff** know and comply with these instructions and the other integrated instructions.

2.7 Faults

In the event of a safety-related malfunction, switch off the unit and make sure it cannot be switched back on accidentally or without authorisation.

You should also switch it off if you notice anything unusual during operation, such as:

- unusual noises
- unusual or strong vibrations
- odours
- smoke
- unusual responses from the monitoring units
- incorrect responses



Danger

Taking the wrong action when troubleshooting may put staff and the vessel at risk.

Risk of injury!

Faults – especially those involving work on electrical and pneumatic systems – must only be rectified by trained, **qualified staff**.



Important

Safety regulations

When working with the vessel, always adhere to the applicable safety regulations and legal requirements.

Take note of the 'Safety information' section in these instructions.



Important

Safety in the event of a fault

Familiarise yourself with the unit's safety devices, and especially with how the unit responds in the event of a fault (e.g. compressed air failure) or when an emergency stop is triggered. Note the information in the description of the control unit.



Important

For detailed fault analysis of third-party components, refer to the instructions provided by the supplier in question.





Important

Problem still not solved?

Get in touch with us at:

RAFF+GRUND GmbH
Max-Eyth-Str. 9-13
71691 Freiberg am Neckar, Germany
Tel.: +49 71 41 2771-0 (switchboard)
Email: info@raff-grund.de



Important

Safety regulations

Faults that operators cannot rectify by simple means (without causing a hazard) must be investigated, analysed, and where applicable rectified, by **qualified staff**.



Take account of section 2 'Safety information' and its subsection 'Staff training' in these instructions.

2.8 General safety information

Depending on the design of the complete machine and integration of partly completed machinery, a variety of risks may arise. Only operate the machine/unit when its protective devices, safety functions and fixed and movable guards are fully installed, inspected and working correctly.



Danger

Risks posed by protective devices/safety functions that are incorrectly installed, not working correctly or not inspected.

Standing in or encroaching on the machine's work area can seriously injure or kill someone. For example, body parts can be crushed, cut off or pulled in.

- **Only operate the machine when its protective devices/safety functions are fully installed, inspected and working correctly.**



2.8.1 Pneumatic components

Work on the pneumatic system must only be done by appropriately trained **qualified staff** who are responsible for this work. Do not adjust or deactivate integrated safety valves and sealed valves without the help of qualified staff. Inspect pressure lines/hoses and screw fittings regularly for damage. Repair leaks immediately.

The pneumatic/hydraulic components include:

- Maintenance and pressure regulation units
- Valves
- Pipes
- Hoses
- Plug-in connectors
- Other pressurised machine parts



Warning

Disconnecting over pressurised connectors

Disconnecting pressurised connectors can cause a violent release of pressure, which may for example cause hoses to whip around.



Consequences:

This can lead to e.g. serious eye injuries.

- Only qualified staff are permitted to work on the pneumatics, taking account of the specific hazard information.
- Do not carry out work on the pneumatics (e.g. repairs or operator interventions) unless the system has been depressurised.
- Wear safety goggles when working on the pneumatics.



Warning

In the event of an emergency stop, some circuits may remain pressurised depending on the valve type installed and the circuit set-up.

Consequences:

Risk of injury!

- Before any operations on pneumatic components, make sure that they are depressurised.
- Vent the compressed air supply on the maintenance unit.

Important: The compressed air circuits in front of the maintenance unit remain pressurised after an emergency stop.



Warning

Slip, trip and fall hazards

Poor or incorrect installation (e.g. installation ducts laid on the floor and running to machine/unit access areas, electrical cables, pneumatic hoses or pipelines laid with no covering) can cause people to trip and fall. An installation duct laid on the floor may cause someone to trip and fall.

Consequences:

This can result in serious or fatal head injuries.

- Mark unavoidable trip hazards in yellow/black.
- Plant owners laying electrical cables to the machine (e.g. for mobile equipment) must ensure that these do not cause a trip hazard.
- When installing the required installations (ducts, lines, cables, hoses and pipes), qualified staff must ensure that these do not cause a trip hazard.



2.8.2 Electrics

EN 60204 specifies that for safety reasons only **qualified staff (electricians)** are permitted to work on electrical equipment with a rated voltage of > 50 V AC or >120 V DC.

This means that unauthorised persons are forbidden to open or work on control cabinets, terminal boxes and connectors! Always use original fuses and circuit breakers with the specified current rating and characteristics. If a fault occurs in the electrical power supply, switch off the unit immediately and inform the responsible department straight away.



Danger – electric current or electrical voltage!

Direct contact

Directly touching live conductors with a voltage of > 50 V AC or > 120 V DC can give someone an electric shock that is strong enough to kill them.



Indirect contact

If there is a fault (e.g. faulty isolation due to a damaged cable), live conductors with a voltage of > 50 V AC or > 120 V DC may touch conductive parts (e.g. the machine frame). This can give someone an electric shock that is strong enough to kill them.

Consequences:

Serious or fatal injury

- Electrical operating equipment (control cabinets/terminal boxes) bearing a lightning bolt symbol must only be opened by qualified staff (electricians/electrically instructed persons (EIP)). It must not be possible to open these without a tool.
- In an emergency, switch off the plant at the main switch (emergency stop).

Electricians must comply with EN 60204 safety regulations when carrying out work:

1. **De-energise**
2. **Check that no voltage is present**
3. **Secure against restarting**

optional:

4. Earth and short circuit (if required)
5. Cover or block off adjacent live parts (if required)

Work on the unit's electrical equipment must only be done by **qualified staff** – an electrician, an electrician assigned specific tasks, or an electrically instructed person (EIP) under the management and supervision of the electrician in charge. Work must always be done in accordance with electrotechnical regulations and the circuit diagram, and with suitable tools and equipment. Faults identified on electrical installations must be rectified immediately. If the risk is serious, stop using the unit or the operating materials concerned. Before inspections, maintenance and repairs on electrical installations, switch off the unit completely and secure the main switch against being switched back on. Then check de-energised parts to make sure no voltage is present. If necessary, earth and short circuit them, and cover, block off or isolate adjacent live parts.

2.8.3 Chemicals



When using oils, greases and other chemical substances, follow the product safety regulations.

Plant owners must supply the hazardous substances for this machine/unit, along with their safety data sheets.

Plant owners must apply and comply with the usage requirements and safety information in the data sheets.

Dispose of environmentally hazardous substances responsibly according to the manufacturer's instructions and safety data sheet. Do not dispose of used chemicals as standard waste.



2.8.4 Noise



Achtung

Fatigue and noise in the workplace increase the strain on staff, which in turn increases the risk of accidents.





Risk of accidents!

- Do not operate the unit unless all protective devices designed to reduce noise exposure are in place and working properly, especially all panels and covers.
- Take your prescribed breaks and use them to rest.
- At a continuous sound pressure level of $L_{EX,8h} \geq 80$ dB, hearing protection is recommended; at $L_{EX,8h} \geq 85$ dB it is mandatory.

For information on airborne noise emissions see section 5.5

2.9 Specific safety information

2.9.1 Leaking fluids due to a fault

 Warning	<p>Slip, trip or fall hazards Fluids escaping from leaky vessels or lines can cause a slip hazard on the floor, or on platforms where applicable.</p> <p>Consequences: Slipping can lead to serious or fatal injuries.</p> <p>Prevention/corrective action:</p> <ul style="list-style-type: none">• Ensure that operators carry out regular inspections, for example in order to identify leaks promptly.• Keep the area and work area around the vessel, and any platforms, clean and tidy.• Clear up escaped fluids immediately and dispose of them in accordance with their safety data sheets.	
---	---	---

 Danger	<p>Risk of chemical burns, burns, scalding and/or explosion due to escaped fluids from leaky vessels/lines</p> <p>Consequences: Chemical burns, burns and scalding can cause serious or fatal injuries.</p> <p>Prevention/corrective action: Ensure that operators carry out regular inspections, for example in order to identify leaks promptly.</p>
--	---

2.9.2 Inspection/operational access points

 Danger	<p>Risk of chemical burns, burns, scalding and/or explosion due to escaping fluids and steam</p> <p>Consequences: When opening the cover there is a risk of chemical burns, burns, scalding and/or explosion that can cause serious and sometimes fatal injuries</p> <p>Prevention/corrective action: Do not open the cover unless the vessel is depressurised and completely empty</p>
--	--

2.9.3 Reaching/climbing into the vessel



Danger

Do not reach or climb into the vessel unless it is completely empty, it has been thoroughly cleaned, vented and ventilated, and you are sure that no fluids (lyes, acids, hot liquids or carbon dioxide) can enter via connected lines.

- Switch off the main switch and secure it against being switched back on.
- Depressurise the vessel/unit.
- Always ensure the vessel is well-ventilated. As far as possible, inspection and operational access points should be open so as to help the air circulate.
- Anyone climbing into the vessel must always be monitored and safeguarded by a second person, using a safety harness and cable.
- Do not use any electrical equipment or lamps inside the vessel unless they are appropriately protected and approved.
- On vessels with an integrated agitator, always shut down the agitator before any servicing work.

2.9.4 Vessel heating (OPTION)

The vessel can be heated e.g. electrically via coils or pads, via carrier media such as steam, hot water or thermal oil in a double casing, via half-pipe coils, or by heating the product externally.



Danger

- Burns from touching the vessel or its add-on components. Make absolutely sure that staff cannot deliberately or accidentally touch the vessel or its attachments as this can cause burns (see also EN ISO 13732-1:2008-12).
- Media that have reached or exceeded their ignition temperature can cause a fire or explosion.
- **Plant owners are responsible for ensuring that surface temperatures are monitored and do not exceed the allowable maximum.**



A 'Warning: hot surfaces' sign is affixed to the vessel cover. Designed to withstand approx. 2,000 temperature changes.



When cold



When heated (> 55°C)



2.9.5 Cleaning the vessel

 Danger	During CIP cleaning, the vessel and its add-on components reach temperatures > 50°C	
	Burns from touching the vessel or its add-on components. Make absolutely sure that staff cannot deliberately or accidentally touch the vessel or its attachments as this can cause burns (see also EN ISO 13732-1:2008-12).	
	Plant owners are responsible for ensuring that surface temperatures are monitored and do not exceed the allowable maximum.	

A 'Warning: hot surfaces' sign is affixed to the vessel cover. Designed to withstand approx. 2,000 temperature changes.



 Important	Plant owners are responsible for using suitable cleaning agents.
	Dispose of used substances and materials responsibly, in particular: ➤ When cleaning with substances hazardous to water.

2.10 Design or structural modifications to vessels

Do not modify the vessel or any of its add-ons or equipment without obtaining written permission from the manufacturer. This applies especially to welding or modifying load-bearing parts.

 Important	Risk of fire!
	Never carry out welding or grinding work on insulated vessels. The insulation material is flammable.

2.11 Fighting a vessel fire

2.11.1 Fire fighting on vessels with electrical equipment



When fighting a fire, it is vital to disconnect the power source for components such as agitators and pumps, otherwise you cannot fight electrical fires effectively.



Safety training

To provide special training on how to fight fires involving or near electrical components, refer to DIN VDE 0132, which deals specifically with this subject.

2.11.2 Fighting external fires



In the event of an external fire, operators should keep vessels and their components, pipes, frames, platforms and ladders, etc. as cool as possible by dousing them with water and foam. Do everything possible to prevent the vessel and pipes from bursting.

Electrical fires must be also dealt with accordingly in the event of an external fire.

3. Declaration of conformity (PED/MD/ATEX)

See supplementary sheet in vessel documentation

4. Information on ATEX requirements

Plant owners are responsible for providing an explosion prevention plan, an explosion protection document and zone classifications in line with ATEX Directive 2014/34/EU.

The vessel takes account of the following ATEX zones/temperature classes:

In the vessel:	Zone 2
Outside the vessel:	no zone
Temperature class:	T4

Vessel acceptance including issuance of the CE declaration of conformity is part of customer acceptance for the whole unit.

If the equipment is integrated in a higher-level machine or system, plant owners must assess the new risks arising from integration.

Customers must specify and document the ATEX requirements for operation, installation, maintenance, commissioning and decommissioning. These important safety notes and requirements per directive 2014/34/EU (ATEX) must be taken into account.

Modifications and repairs to the above-mentioned equipment are not permitted without the manufacturer's express written consent.

5. Product description

5.1 Intended purpose

The vessel described in these instructions is designed to fill with and manufacture fluids in the medical and pharmaceutical industry.

Vessels must be used exclusively for the above-mentioned specified intended purpose and according to the order/order confirmation from:

x

x

The supplier accepts no liability for damage caused by using the vessel for any purpose other than that specified above.

Changing the intended purpose requires the manufacturer's written approval.

5.2 Scope of use

The machine is designed for commercial use only.

5.3 Compatibility of materials



Achtung

Plant owners must check that the materials will withstand the media/fluids used.

Plant owners must verify this for product media and cleaning and flushing media, by referring to DIN 6601 Resistance of materials of steel vessels against liquids.

5.4 Technical data (basic data)

Vessel type:	Pressure vessel		
Filling medium:	Product solution		
	CIP medium		
Net capacity:		15	litres
Gross capacity		20	litres
Vessel weight when empty:		approx. 185	kg
Vessel weight when filled:		---	kg

Dimensions

Diameter (interior):	250	mm
Casing thickness:	3	mm
Diameter (exterior):	306	mm
Casing thickness:	3	mm
Cyl. height (interior vessel):	ca. 350	mm
Vessel height (with cover + feet):	ca. 790	mm
Flange thickness:	23	mm
Cover thickness:	23	mm

Operating pressures/temperature – interior

Vacuum:	-1	bar
Maximum allowable pressure PS:	+3	bar
Test pressure PT	6,8	bar
Min./max. allowable temperature TS	-10 / + 95	°C

Operating pressures/temperature – casing

Vacuum:	-1	bar
Maximum allowable pressure PS:	+6	bar
Test pressure PT	10,6	bar
Min./max. allowable temperature TS	-10 / + 95	°C

EX protection zones

Inside the unit:	Zone 2
Outside the unit:	---

5.5 Airborne noise emissions

Information on airborne noise emissions as per EU Machinery Directive 2006/42/EU Annex I - 1.7.4.2 u):

Emission sound pressure level L_{PA} at the workstation	< 70 dB(A)
---	------------

5.6 Vessel drawing

See drawing(s) in vessel documentation

5.7 Electrical data

See separate documentation for control cabinet/control unit

5.8 Vessel features

These vessels are used for filling with fluids for production plants in the medical and pharmaceutical industry. The vessels can be used for mixing and cooling processes.

They are mounted on a mobile frame with 4 steerable, conductive castors.

They are cleaned by flushing and/or with integrated spray heads via a central CIP unit.

Vessel equipment (optional in some cases):

- Vessel mouth (inspection access point)
- Vessel insulation with welded insulation casing and insulator
- Cooling zone
- Cold water supply
- Cold water discharge
- Product inlet pipe
- Agitator
- Bottom drainage valve
- Fill level limit switch
- Fill level indicator
- Temperature indicator
- Pressure gauge
- Sampling port
- CIP connection port

5.9 Add-on components



For add-on components such as the control unit, control cabinet, agitator, pump and valves, see separate manufacturer instructions and/or hazard analyses appended to the documentation.



6. Transport

For dimensions and weights see the relevant drawing(s) in the vessel documentation.

6.1 Scope of delivery

Check the delivered goods against the delivery note to ensure that nothing is missing, and check the machine for transport damage.



Important

Report transport damage immediately

If you notice any transport damage, please send us details of the nature and extent of the damage immediately (along with the delivery note number, machine type and serial number):

RAFF+GRUND GmbH
Max-Eyth-Str. 9-13
71691 Freiberg am Neckar, Germany
Tel.: +49 71 41 2771-0 (switchboard)
Email: info@raff-grund.de

6.2 Stipulations regarding staff involved in transport

The vessel must only be transported by staff who are trained and/or experienced in transporting heavy vessels. Make sure that no one is in the hazard zone when the vessel is being moved.

Cordon off the hazard zone to prevent unauthorised access.

Qualified staff must be in a position to assess and carry out the tasks assigned to them, to identify risks and to take safety precautions.

6.3 Transport

When transporting the machine, always handle it appropriately. The transport method, including slings, chains, ropes and webbing, must be designed for the machine weight including the integrated tool and accessories.

Unless otherwise agreed, the machine is delivered ready for installation. Do not disassemble the machine for transport.

Always check all machine components for damage after transport.



Important

When transporting the vessel or its parts, follow the plant owner's safety regulations.



Preliminaries before transporting the vessel:



- Shut the vessel down
- Empty the vessel
- Secure the vessel against pressure differentials
- Secure any loose parts

6.4 Storage

If for operational reasons you need to store the vessel, proceed as follows:



- Store in a dry environment protected from frost
- Store in a low-dust environment and cover the vessel
- Do not assemble the vessel in areas close to sparks or steel particles → risk of corrosion
- Empty and dry the vessel and its pipelines/hoses
- Cap/cover all pipeline components
- Storage temperature: 10°C...50°C
- Clean the outer vessel and protect it appropriately from damaging environmental conditions, rust bloom and other factors

7. Assembly, set-up and acceptance

7.1 Assembly and set-up

- The customer assembles and sets up the unit.
- The unit must be properly installed at the installation site/place of use.
- If the unit is to be in a fixed location, make sure that all machine feet are subject to the same load and that the unit is level.

Bear in mind that the load-bearing properties (kg/m²) of the surface for the vessel must be sufficient and include a margin of safety.

 <p>Important</p>	<p>Unit weight</p> <p>The site must be designed to take the weight of the whole vessel including its accessories. Based on the empty weight, take account of the load applicable during processing (dynamics and vibrations).</p> <p>Refer to the relevant drawing in the vessel documentation for information on weight.</p> <p>Only allow qualified staff (competent persons) to set up the unit.</p>	
---	---	---

- Ensure that there is enough space for the unit.
- Take account of the space required for supply lines as well.
- Specify the work area and ensure it meets applicable requirements (especially ergonomics and safety).
- Remove the packaging materials and dispose of them in an environmentally safe manner.

7.2 Overview of connections

Media line connections (product supply/discharge, cooling flow/return, CIP cleaning) → see vessel drawing including table of fittings

Electrical connections → see control cabinet + control unit documentation

Pneumatic connections → see control cabinet + control unit documentation

7.2.1 Connecting the power supplies



Danger

Danger – electrical voltage



Working with voltages > 50 V AC and > 120 V DC can cause an electric shock that is strong enough to kill someone.



Before commissioning the plant, check the connection cables of the electrical supply lines and control lines for kinks and damage. If they are visibly damaged, have them replaced by RAFF+GRUND GmbH or an electrician before connecting the machine.

Once the electrical installation work is complete, run through the statutory electrical checks such as protective conductor continuity, equipotential bonding and RCD tests.

If the machine is to be connected by the plant owner, the plant owner must carry out and document electrical tests to EN 60204. Recurring inspections are also required.



 Warning	<p>Trip/fall hazard!</p> <p>Incorrectly installing and laying electrical cables, pneumatic/hydraulic pipelines or hoses or supply hoses can cause people to trip or fall.</p> <p>Please do a final check to ensure that none of the completed installation work, e.g. cables, pipes, hoses and ducts, are a trip or fall hazard.</p> <p>Only allow qualified staff (competent persons) to install and connect the plant.</p>	
---	--	---

If the machine is delivered ready for operation, connect the control cabinet/control unit to it via the pre-installed connection cable, using the existing power supply.

1. Connect the control unit to the power supply in accordance with the information on the circuit diagram (rated voltage, rated current, rated frequency).
2. Switch on the main switch and control unit as described in the instructions.

 Danger	<p>Earthing the vessel</p> <p>Mobile vessels require an earth clamp.</p>
---	---

If you find a safety-related fault in the electrical installation, disconnect the machine from the power supply and have the electrical installation checked by authorised, **qualified staff**.

 Important	<p>Danger – pneumatic components!</p> <p>Before switching on the air supply, check that hose lines and connections are correctly installed and securely fitted to prevent them from unintentionally coming loose.</p> <p>Only allow qualified staff (competent persons) wearing safety goggles to install and connect the pneumatics.</p>	
---	---	---

Unless otherwise agreed, the machine leaves the factory with as many of the hoses and pipes connected as possible.

When connecting additional media lines, follow the operating parameters for the unit.

7.3 Acceptance

Overall unit acceptance (PED, MD, ATEX) is done by an authorised representative of the customer.

Commissioning must not take place until the pressure equipment is correctly installed in a plant, corresponding limiter devices are in place, set-up conditions have been taken into account, and the assembly, set-up conditions and functional safety of the vessel have been checked.

Plant owners must arrange the pre-commissioning inspection. In Germany it must be carried out in line with Section 14 of the German Industrial Safety Regulation (BetrSichV). In other countries, the pre-commissioning inspection must comply with the applicable national requirements.

In Germany, the pressure equipment is subject to recurring inspections arranged by the plant owner pursuant to Section 15 BetrSichV to ensure it remains in proper condition. In other countries, users must comply with the applicable national requirements.

8. Operating the unit

8.1 Commissioning requirements

The following requirements must be met before commissioning:

1. Verify compliance with national legal requirements.
(e.g. Germany: BetrSichV, Europe: directive on use of work equipment)
2. Ensure that all machinery is correctly installed and connected to the supply lines provided.
3. Check that no pipe/hose connections are leaking.
4. Set the operating parameters to the specified values.
5. Before commissioning, familiarise yourself with the operating and control elements of the machinery, especially the protective devices.
6. The initial inspection of all protective devices must be done by **qualified staff** (competent persons).
7. If using hot or cold media, check all screw fittings on connections during and/or shortly after commissioning.

8.2 Operating the unit



For information on how to operate the vessel/unit and how to use operating modes for processes, see separate documentation.

8.3 Earthing

The vessel requires an earth clamp. The vessel has conductive castors.



Important

Earthing

Before operating the vessel, attach the earth clamp to a suitable point and have staff check that it is properly in place.



8.4 Add-on components



Follow the separate manufacturer instructions or hazard analyses appended to the documentation.

8.5 Filling/emptying



Important

Before commissioning the vessel filling or emptying process, check that:

- the inspection and operational access points are properly closed.
- valves are open or closed according to specifications.
- safety valves, pressure relief and vacuum regulator valves are set correctly for the filling and emptying capacity and are working correctly.



8.6 Moving the vessel



Caution

To move the vessel, use the integrated, electrically conductive castors. Only move it on even surfaces without ramps or steps! Do not move the vessel until it is disconnected from the mains and all power supply, earth and signal cables are also disconnected.



Coil the cables and store them on the cable holders provided (both sides of control cabinet) to prevent them from getting damaged.



Important

People in the area around the vessel must wear safety boots when the vessel is being moved.

To push the vessel along on its castors, release the parking brakes. You can then move the vessel manually using the push handle. To prevent personal injury or property damage, move it cautiously, checking that there are no people or objects in its path.

After moving the vessel, make absolutely sure you re-engage the parking brakes on the wheels and re-attach the earth immediately.



9. Decommissioning



Decommissioning requirements

Before decommissioning the unit, make sure it is depressurised. Do not open the unit unless it is empty and has cooled down!

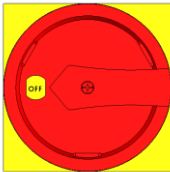

Step	Procedure	Illustration/control
1	Switch off main switch	
2	Close all valves on supply/discharge lines	
3	Disconnect all power supply and signal cables	
4	Disconnect earth cable	



Electrical equipment may continue to carry a live voltage that is strong enough to kill.

Risk of fatal electric shock!

- The power supply must be disconnected by an electrician!



5	Disconnect all pneumatic connections	
---	--------------------------------------	--





Risk of bursting!



Pneumatic systems are pressurised. If dismantled incorrectly they can burst and cause serious accidents.



- Never unscrew or pull these screw fittings when the unit is switched on. Depressurise the pneumatic equipment and shut off the compressed air supply before doing any work on pneumatic components.
- Wear safety goggles when doing this work.



 Caution	Risk of excess pressure in pneumatic system.	
	<p>Risk of injury!</p> <p>If lines and components come loose or burst, hoses may whip around and components and/or splitters may fly off. This can result in serious skin or eye injuries.</p> <ul style="list-style-type: none">• Before working on pneumatic components, switch them off by disconnecting them from the main pressure supply, secure them against restarting and depressurise them.• Wear safety goggles when doing this work.	

6	Remove all media lines	
---	------------------------	--

 Danger	Media in lines	
	<p>When you open a line, some of the medium inside it may escape.</p> <ul style="list-style-type: none">• If the unit is filled with a medium that is dangerous to operators, before opening a line, make sure that operators will not come into contact with the medium.• Clear up escaped fluids immediately and dispose of them in accordance with their safety data sheets.	

 Important	Extended decommissioning	
	<p>When decommissioning the unit for extended periods, empty it completely. Leave the unit depressurised.</p> <p>We recommend air-drying the pipelines to prevent interior corrosion.</p>	

10. Cleaning



Depending on the design of the vessel, it is cleaned with a spray head or by flushing. The vessels are connected to a central CIP unit.



Cleaning agents

Plant owners are responsible for using **suitable cleaning agents**



11. Repairs



Safety regulations

When working on the machine, always adhere to the applicable safety regulations and national legal requirements.



Take note of the 'Safety information' section in these instructions.

RAFF+GRUND GmbH products must be properly maintained, repaired and inspected by appropriately **qualified staff** (competent persons). The plant owner/employer responsible for the vessel, or a designated person in that employer's organisation, must ensure that staff are properly qualified to maintain and repair the vessel and to carry out initial and recurring inspections. Alternatively, the plant owner must have the manufacturer carry out this work as the manufacturer is appropriately qualified.

Unless otherwise specified, do not work on the vessel unless ...

1. hazardous movements have completely stopped.
2. the machine's compressed air supply is safely switched off and the pressure circuit has been vented.
3. the unit and/or its components are completely empty and cool and there is no risk of burns (< 40°C).
4. the unit and/or its components have been purged and vented.
5. the upstream and downstream components and utilities connected to vessels, e.g. compressed air and hydraulics, have been secured against starting up unexpectedly.
6. the unit's electrical power supply is switched off and secured against being switched back on.
7. precautions have been taken against unauthorised, accidental or unexpected hazardous movements due to accumulated energy.
8. vertical/swivel units have been secured against descending or dropping.
9. sufficient fall-prevention measures have been taken for work at height.
10. adequate lighting has been provided for the work required.
11. all the necessary technical documents are to hand. (circuit diagrams, instructions etc.).

Only use RAFF+GRUND GmbH original parts.



Rectify defects immediately

If you identify a defect, rectify it immediately and have the root causes properly eliminated.





Fitting and inspecting protective devices



After any repairs or maintenance, refit removed protective devices correctly.

Before the plant owner's operators commission the machine, maintenance staff must check that all safety functions are working.

Also check that all connections and screw fittings are secure, with no leaks.



Important

Do not modify the machine!

Unauthorised conversions or modifications to the machine, or using replacement components that do not correspond to the manufacturer's original equipment (mechanical, hydraulic or pneumatic) can put people, the whole machine and other property at risk.



Important

Safety regulations

When working on the machine, always adhere to the applicable safety regulations and legal requirements.

Take account of the 'Safety information' section in these operating instructions.



Important

If the vessel has been temporarily decommissioned, carry out all the maintenance below before recommissioning.



Important

Statutory safety inspections



Please refer to the applicable national requirements on conducting safety inspections.

Take account of the 'Safety information' section in these instructions.

Where applicable, adhere to the inspection requirements of the various component manufacturers.

11.1 Maintenance

Comply with the specified intervals for recurring inspections, maintenance and repairs as prescribed in these instructions or in other relevant specifications. This work must only be carried out by designated, trained and instructed **qualified staff**. Note that certain inspections require you to appoint a competent person (electrical inspections, non-contact safety devices – light curtains, etc.).

If the unit is completely shut down for maintenance and repairs, it must be secured against restarting unexpectedly:

- Attach a warning sign to the main switch





If safety devices have to be removed or adjusted in order to carry out maintenance and repairs, it is vital to refit, readjust and check them immediately after the work is finished (e.g. emergency stops, emergency stop buttons, movable safety doors, guards and relief valves). Provide sufficient lighting when working on the unit.

Persons working on the unit must wear the necessary personal protective equipment (e.g. safety goggles, safety boots, hard hat) and must only use approved tools and measuring instruments.

Keep all handles, steps, railings, platforms and ladders free of soiling.

After working on the unit or after an operational stoppage, before recommissioning and restarting the unit, make sure no one is in the hazard zone.

After carrying out work that requires the unit to be opened, run a pressure test to check for leaks.

 Danger	<p>Fall hazard!</p> <p>Carelessness or material damage can lead to falls and cause injury.</p> <p>Do not use unit parts as climbing aids.</p>	
 Danger	<p>Danger – suspended loads!</p> <p>Carelessness or material damage can lead to falling loads. People standing under these loads can be seriously injured or killed.</p> <p>Do not stand under suspended loads.</p> <p>If you need to work beneath a suspended load (e.g. machine parts suspended by lifting equipment), make the work area safe with suitable supports (e.g. wedges or plates) to ensure that units cannot drop.</p>	

11.2 Maintenance intervals

Maintenance intervals



In addition to the intervals listed below, take account of all maintenance intervals in the instructions for the installed components, such as agitators and pumps.



TIME INTERVAL	MAINTENANCE INSTRUCTIONS
Before each batch	<ul style="list-style-type: none"> Visually inspect the exterior of the vessel, pipes and hoses for leaks and damage/corrosion
Every 6 months	<ul style="list-style-type: none"> Replace TC seals Inspect the reusable hoses to check if the material is brittle Inspect the bolted connections on the agitator motor and tighten if necessary
Once a year	<ul style="list-style-type: none"> Diaphragm valves: replace diaphragms Function check limit switches All safety valves: check set pressure Function check: filling/emptying valves Function check: emergency stop Inspect burst disk for soiling, corrosion, discolouration, defects, cracks or other damage; replace if necessary. Inspect cover seals for damage (brittleness, cracks etc.) replace if necessary. Inspect spray balls (if installed) for contamination Function check the temperature-controlled warning sign
Every 2 years	Inspection of exterior (as per BetrSichV)
Every 5 years	Inspection of interior (as per BetrSichV)
Every 10 years	Strength test (as per BetrSichV)

11.3 Recurring inspections

For safety reasons, machinery is subject to recurring inspections by competent persons.

In Germany, the pressure equipment is subject to recurring inspections pursuant to Section 15 of the German Industrial Safety Regulation (BetrSichV), to ensure it remains in proper condition.

Please refer to BetrSichV Section 16:

Annex 1 – para 3 explosion risks

Annex 1 – para 4 pressure systems

For the applicable inspection intervals see TRBS 1201, and for requirements concerning the competent person/inspector see TRBS 1203. (TRBS – Technische Regeln Betriebssicherheit [Technical Rules for Operational Safety])



11.4 Ordering spare parts

Please provide the item number from the spare parts drawing as well as the part number and designation from the associated parts list:

- Search for the item number of the spare or defective part in the corresponding exploded drawing.
- Use the item number from the drawing to find the part number and designation in the associated parts list.

12. Environmental protection

 Important	Compliance with environmental regulations Adhere to national noise and environmental regulations when doing any work on the unit.	
---	---	---

 Important	Disposal When disposing of wear and spare parts, or of the unit and its accessories, adhere to the national environmental protection regulations applicable at the time of disposal.	 
---	--	--

	Disposing of hazardous materials Protect the environment. At the end of their useful life, send hazardous materials such as lubricants or batteries to specialist disposal centres. Before dismantling for recycling or scrapping, thoroughly remove all oil, grease, and substances hazardous to water. Follow the applicable environmental regulations.
---	--

When choosing the necessary operating materials (e.g. lubricants, lubricating oils, filter cartridges and cleaning agents), note their environmental impact and health risks and the applicable disposal regulations.

13. Appendix

13.1 Declaration of knowledge by assigned staff

Mr/Ms:

the person assigned by the plant owner, hereby confirms having read and understood the in-house instructions and the machine instructions, especially the 'Safety information' section, regarding

Unit: Vessel 20L

Serial/tag number: _____ (for completion by plant owner)

and its accessories.

Place/Date

Assigned person

Place/Date

Instructor/plant owner

Confirmation of training

The plant owner should have the staff confirm in writing that they have been inducted or trained in such a way that they can safely operate, maintain, repair, and competently inspect the machine.

- Make a copy of this form, 'Declaration of knowledge by assigned staff', for each person trained.
- After the training, have each trainee sign a copy and have the instructor countersign it to confirm that the trainee took part in the training.
- Store these documents in a safe place, ideally with the rest of your in-house operating procedures.