

MODEL BV C-Class 24"x48" Post and Beam Vacuum Forming Series



www.belovac.com

Belovac Industries • 435 E. Lincoln St., Ste A • Banning, Ca 92220-4527
Office: (951) 741-4822 • Fax: (951) 922-1494

Equipment Specifications:

Equipment Features

- Sheet size 24x48 (61 x 122cm) (Custom sizes available at request)
- Depth of draw 18 inches
- Fully adjustable material clamping
- Tooling table:
 - 3 1/4" (8cm) Pneumatic drive cylinder 300lb (136kg) seal pressure with adjustable slotted track for rapid tool mounting
- Solid state programmable heat timing unit, coupled with programmable percentage control unit
- Heater Panel: 20,000 watts infrared radiant panel, with size-down option
- Vacuum Pump: High volume, Hi-vacuum pump, Onboard 20 Gallon surge tank
- Construction: Post and Beam, Modular Frame System
- Recommended for plastics
 - ABS - PVC - PET - Poly styrene - kydex - Poly propylene
 - Plastic gauges up to 1/4" (.64cm)

Electric Requirements:

- Power requirement: 220 three phase 40 amps

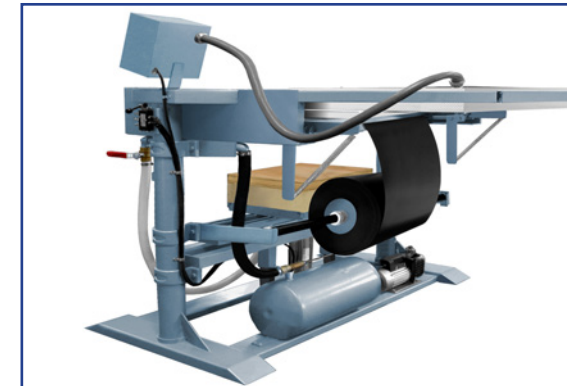
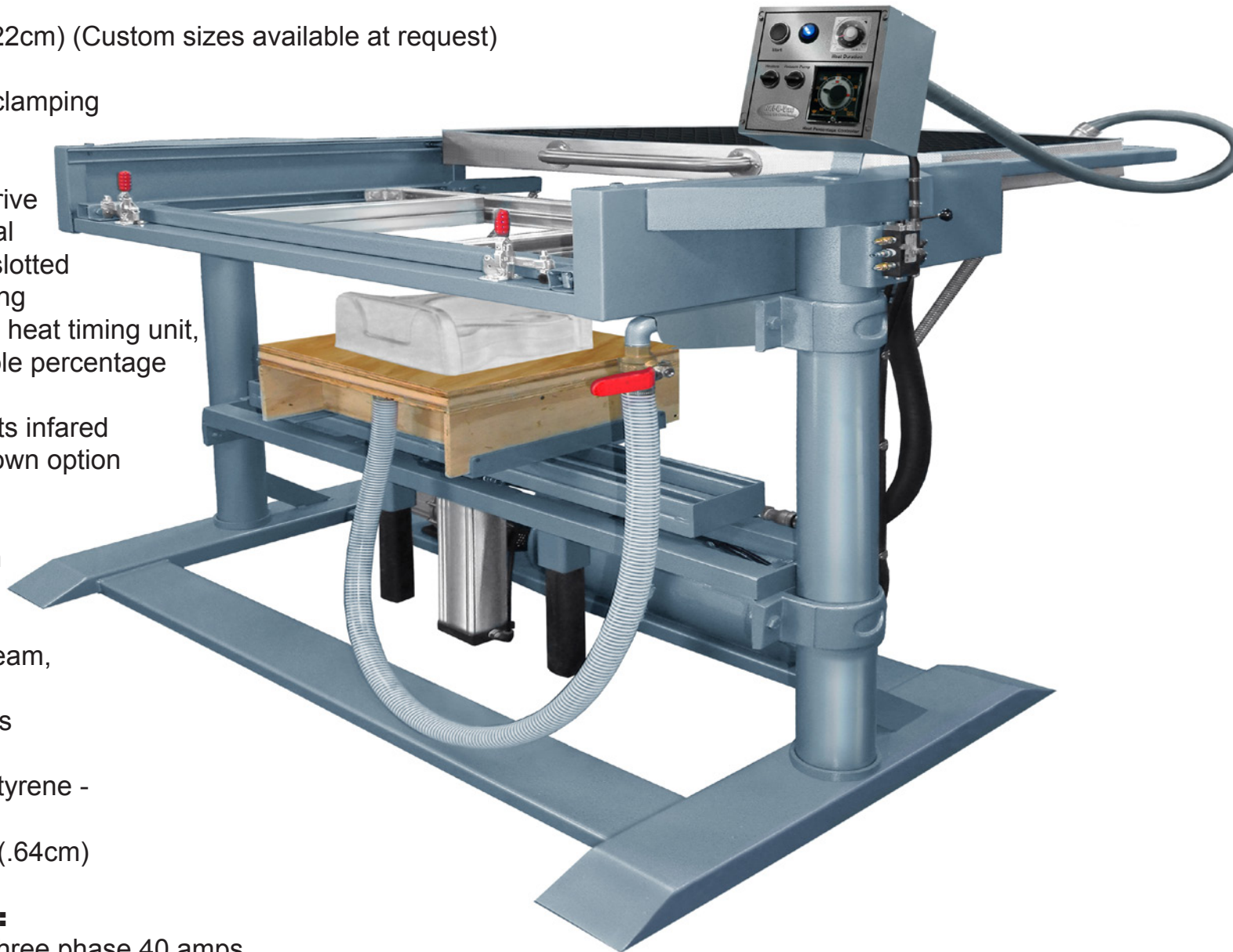

Option: Production Rollholder



Option: Vacuum Former with Overhead Assist



Infrared Heater Panel Featuring:
15,000 Watts of 0 - 100% Heat Controlled

For more information please contact your Belovac Representative at 951-741-4822 or at jb@belovac.com or visit www.belovac.com