

FAST

MULTIDROP®

**MODEL
“Junior”**



Open kart



Closed kart

Multidrop® is a depositor, a dosing machine and a wire cut machine.

Thanks to the 100 programs computer with LCD you can make a wide range of biscuits and confectionery products such as: Bigne', Choux, Eclaires, Sponge Cake, Dobus, Casse, Finger Biscuits, Tuiles, Anicini, Plumcakes, Muffins, Madeleinettes, Meringues, Tortiglioni, Savoy Biscuits, Brasilians, Champagne Biscuits, Shortbread Dough, Shortcakes, Ciambelline, Danish Cookies, Sables, Amaretti, Soft Amaretti, Macarons, Petits Fours, Baci Di Dama, Brutti E Buoni, Coconut Biscuits, Canestrelli, Occhi Di Bue, Chocolate Chips Cookies, Krumiri, Pain D'epices, Offelle, Cantucci, Ricciarelli, Kipfels, Novellini, Palets*

* the list contain only the most common products

ALL MULTIDROP® JUNIOR MACHINES ARE EQUIPPED WITH:

- S/S FRAME; COMPACT DIMENSIONS.
- EASILY DETACHABLE TABLE.
- HEAD EASY TO DISASSEMBLE AND WASH.
- HARD DOUGH HEAD HDD WITH STAINLESS STEEL ROLLERS, WITH ADAPTORS FOR SOFT DOUGH.
- HEAD SIZE SUITABLE FOR 400 AND 460 MM WIDTH.
- SELECTION OF DIFFERENT HEADS SUITABLE FOR DIFFERENT KINDS OF PRODUCTS.
- 100 PRGS COMPUTER WITH GRAPHIC DISPLAY WITH LIGHT ADJUSTMENT
- MOTOR WITH INVERTER FOR ROLLERS ROTATION.
- MOTOR WITH INVERTER FOR NOZZLES ROTATION (FR-FL MODELS ONLY).
- MOTOR FOR TABLE LIFTING WITH AUTOMATIC POSITIONING.
- MOTOR WITH INVERTER FOR AUTOMATIC TRAY ADVANCING.
- MOTOR FOR WIRE CUT FUNCTIONING (FET-FL MODELS ONLY).
- "CE" COMPLIANCE CERTIFICATE.



Ing. Polin & C. S.p.A.
V.le Dell'Industria, 9 - 37135 Verona ITALY
Tel. +39 045 8289111 - Fax +39 045 8289122
www.polin.it polin@polin.it

99999011680

FAST

“Junior”

DIMENSIONS (mm):

Multidrop® Junior FE – FET – FR – FL

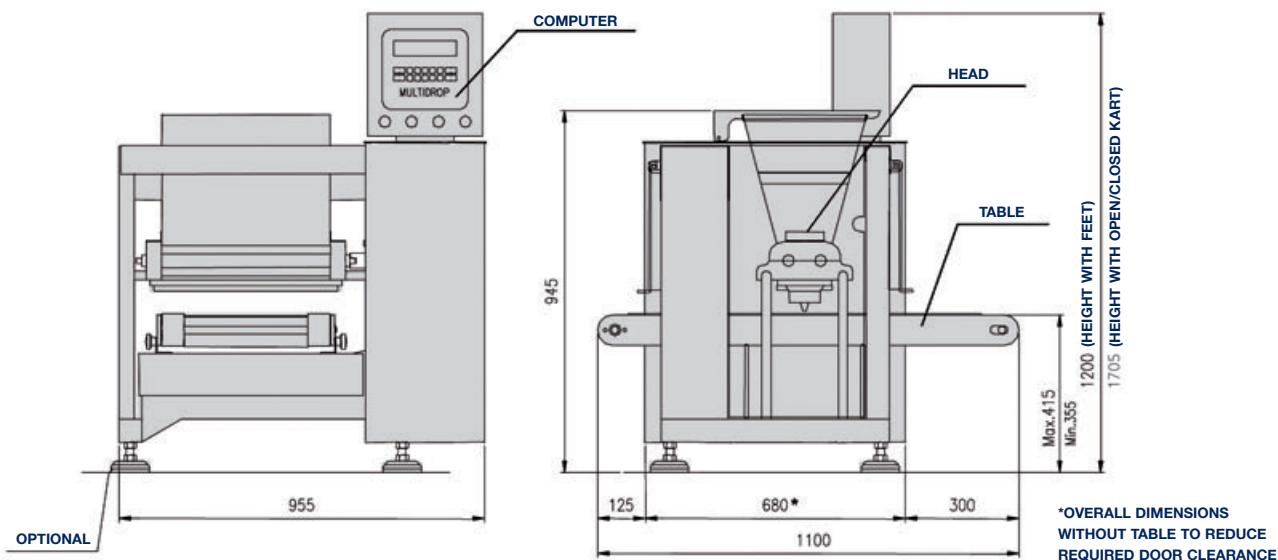

TRAYS DIMENSIONS, TECHNICAL FEATURES, PERFORMANCES, PACKAGING DETAILS FOR EVERY MODEL:

Multidrop® Junior FE – FET – FR – FL

Models:	FE	FET	FR	FL
TRAYS DIMENSIONS:				
Width (mm)	400 - 460			
Lenght (mm)	400 - 700			
TECHNICAL FEATURES:				
Standard voltage (Volt)	400/3N~/50			
Optional voltage (Volt)	230/3~/50 - 220/3~/60			
Power (kW)	1,1	1,2	1,3	1,4
Weight (Kg) net	190	200	200	210
Hopper capacity (Liters)	35	35	35	35
Noise level (dB)	<80			
DROPPED				
Wire cut (Max Strokes/1')*	20	20	20	20
RPM (Max Strokes/1')*		30		30
PACKAGING DIMENSIONS AND WEIGHT (mm)				
Packaging (Kg)	1250x1100xh=1450			
Packaging (mm) gross	240	250	250	260
Packaging (Kg)	1300x1150xh=1500			
Packaging (mm) gross	290	300	300	310
Packaging (Kg)	1250x1100xh=1450			
Packaging (mm) gross	240	250	250	260

*Related to an average rollers rotation time of approx. 1".

EQUIPMENT: HEADS



Hard dough head with rollers.



Hard dough head with rollers "America" type.



Soft dough head with pump.



Soft dough head with pump, with staggered teeth rollers.

EQUIPMENT: ACCESSORIES



Dies and nozzles.



Paper holding device.



Squashing tips device.



Memory card and CD Proges software.

Final products pictures are purely representative. Drawings and technical data can be modified without prior notice from the manufacturer.