

## AZO Cyclone screener type DA 360 N with self-dosing

Patent no. EP0917911 / US6193072

**Control screening**

**Safety screening**

**Fractioning**

**Separation of  
foreign particles**

**Breaking of lumps**

**Aeration of  
products**

### Preferred applications

The DA type of cyclone screener is used for safety screening and fractionating of material, for eliminating foreign matter, breaking lumps, and for lifting/ loosening product. The special feature of this screener type is its self-dosing function, eliminating the use of an upstream dosing device.

### Special advantages

- Low construction height
- No extra dosing device required
- Completely extractable without tools
- Drive with dosing screw demountable by snap locks
- Drive with screen can be extracted and swivelled
- Easy and fast inspection of screen basket
- Nickel chromium steel in different surface versions

## THE INNOVATION



### How it works

Via the product inlet, the bulk material enters the dosing screw, and is transported into the screen casing. Dosing the bulk material as necessary for screening can be done by setting the screw speed by frequency converter to the value specific to the product in question. The bulk material is then taken over by the separately driven intake distributor with fluidizing bars, and gently whirled through the screen basket. The fine material drops through the screen into the outlet for fine product, the coarse material is

transported to the outlet for coarse product, and there gently removed. The special extraction device with snap locks allows simply extracting and swivelling the screen basket to the side for inspection. This makes for thorough inspection and quick exchange if necessary. The dosing screw is also quickly extracted by opening its snap locks. Safety-relevant connections are governed by electric protective devices (safety switches) which switch the machine off the moment such a connection is

opened. The screening mesh is held by rings, can freely vibrate, and thus cleans itself. The built-in baffle prevents too much fine product getting into the coarse-product outlet.

## Technical data

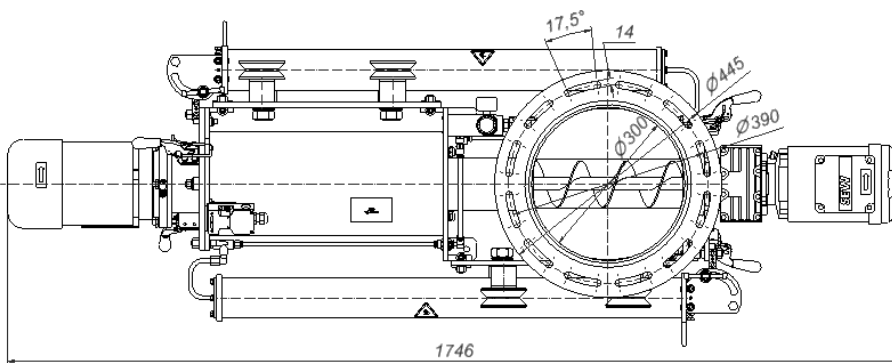
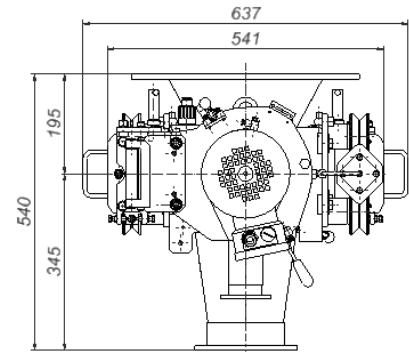
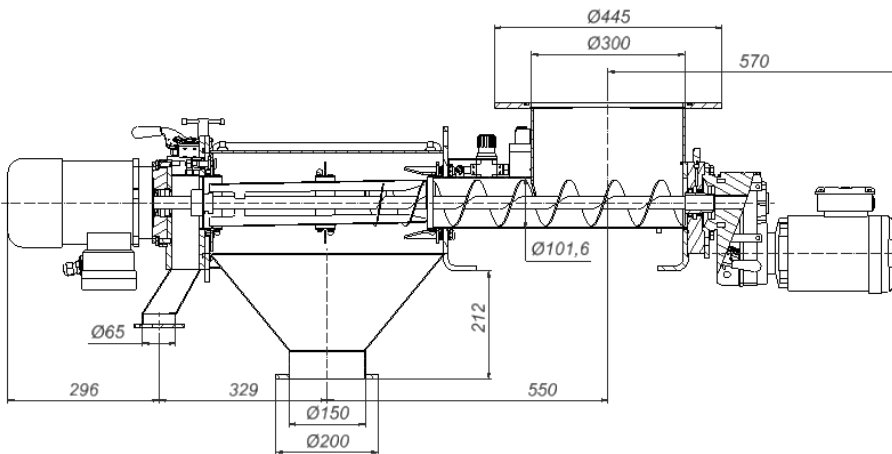

<b>Type:</b>	<b>DA 360 N</b>
Weight:	approx. 150 kg
Drive:	
Metering screw	0.75 kW
Rotor	0.75 kW
Speed:	
Metering screw	177 rpm
Rotor	1500 rpm

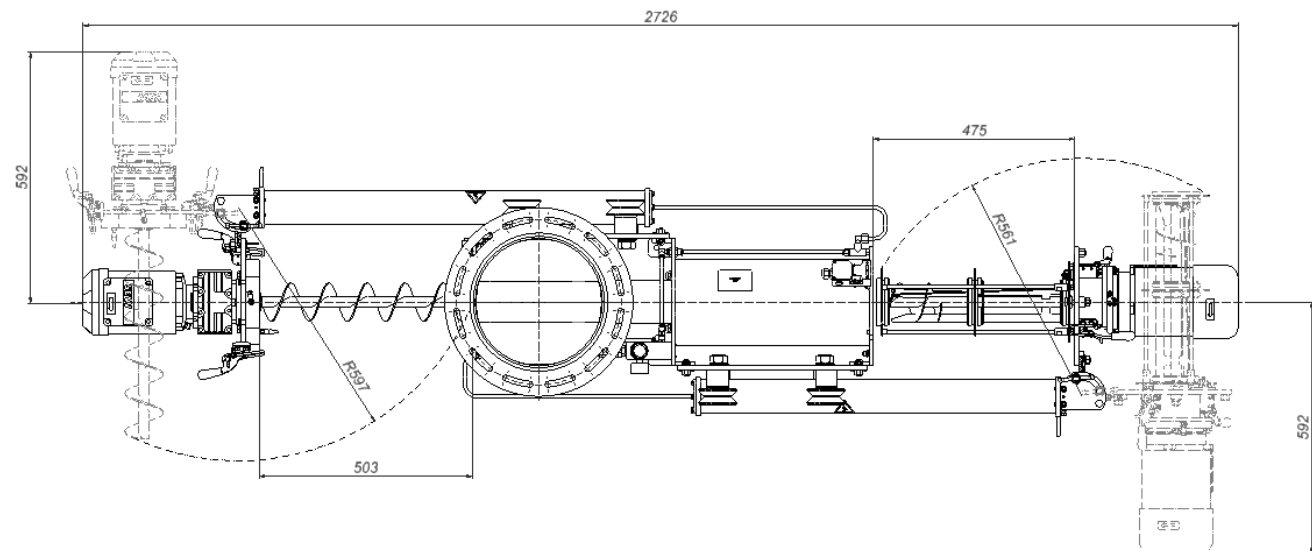

## Output data

Mesh size	Screening output
0.2 mm	= 0.6 t/h
0.4 mm	= 1.1 t/h
0.6 mm	= 1.6 t/h
0.8 mm	= 2.2 t/h
≥ 1.0 mm	= 3.0 t/h

The above output data are approximate values. Exact data may be provided upon request or can be determined by our technology workshop. The data are based on wheat flour with a bulk weight of 0.5 kg/l.



Screen basket swivelled to the side.



Dosing screw with drive, extracted and swivelled to the side.

The design is subject to change due to our continuous improvement program.