

Cascade™ CT2211

Aerosol Microleak Detection System

Emerson's Cascade Technologies is the global leader of packaging leak detection systems for the Aerosol, Food, and Pharmaceutical industries. The Cascade CT2211 aerosol microleak detection system is the first Quantum Cascade Laser (QCL) system developed for automated, in-line leak detection.

Providing instantaneous detection and rejection of faulty cans moving down the production line at a rate of up to 600 cans per minute, the CT2211 supports your facility's requirements:

- As a standard system used after the water bath for detection of microleaks in filled cans.
- As a high sensitivity variant, certified for use as part of a water bath alternative system.

Features

Increased productivity and profitability

- In-line, real-time monitoring and detection of leaks without stopping production
- Instantaneous response time and removal of only non-conforming product
- High sensitivity for positive ID of leakers
- Speed: runs at 600 cans/minute
- Certified for use as an alternative to water bath test
- No calibration for easy maintenance
- Continuous health diagnostics provides proactive indications of maintenance requirements
- Enhanced safety; eliminates leaks of previously undetected hazardous materials during storage
- ATEX certified for use in hazardous environments



Cascade CT2211 Aerosol Microleak Detection System

Applications

With its innovative design, the CT2211 supports a multitude of products and propellant types as per Table 1.

Table 1 Products and propellants

Products	Propellants
Personal care	Propane, Butane, LPG, N ₂ O, CO ₂ , DME, R1234ze, R134a, R227*
Automotive and industrial	
Paints	
Household	
Food	
Medical	

*Other propellants available upon request

Benefits

Improve operating safety.

Failure to detect a faulty can after filling could become a serious safety hazard. Leaking cans may release potentially flammable or explosive gases or liquids, and build-up of hazardous gases in warehouses or during transportation can result in explosions or fires.

The CT2211 is designed to test the entire can regardless of shape or size, ensuring all failure points: valves, crimps, tri-weld, and seams are tested. If and when a leaking can is detected, a signal is activated so the individual can is safely removed from the line for containment. The system can also be configured with an alarm when multiple cans are found to be leaking for advanced analysis.

Comply with legislation and contract requirements.

Aerosol manufacturers must adhere to strict quality control requirements from regulatory agencies and brand owners to ensure only high quality, safe products go out to market.

The CT2211 is fully compliant with all existing industry regulations and standards, including UN, ADR, FEA, and BAMA among others and can help you meet your leak requirements with water bath or as a water bath alternative solution. With its modular design, future propellant changes or performance upgrades are easily managed with little or no down time.

Post water bath	Water bath alternative
8×10^{-3} mbarLs ⁻¹	2×10^{-3} mbarLs ⁻¹
1 bubble / sec at 50 °C	1 bubble / 5 sec at 20 °C

Reduce waste and prevent costly recalls.

The goal of every aerosol manufacturer is to safely maintain a high level of quality control throughout the production process. Leaking cans that go undetected through the production line and are packaged for final delivery can result in costly product recalls and damage to brand reputation.

The CT2211 uses Quantum Cascade Laser technology to instantly detect, identify, and reject a faulty can speeding along the conveyer belt.

Gain greater insight into operations.

The CT2211's easy to use software and detailed user interface gives operators the ability to easily operate the system, see diagnostic information, and monitor the production line performance. With complete visibility of the leak detection statistics, aerosol manufacturers can perform data analysis for continuous improvement of the process.

Your Leak Detection Partner

Lifecycle services and support.

Our team of trained and certified field experts know and understand the requirements needed to develop a customized service program to suit your application. We provide complete turn-key services and problem solving to assist you every step of the way. From pre-installation services to ongoing maintenance and support long after commissioning, we have the expertise to ensure your leak detection systems run at ideal operating conditions during their lifetime.

Services include, but are not limited to, the following:

- Installation
- Startup and commissioning
- Remote system monitoring
- Scheduled maintenance
- Field retrofits
- System upgrades
- On-site training and support
- On-call support

Configuration types

The CT2211 is available in two standardized model configurations to meet different requirements. Other configuration options are available upon request.

Configuration	Carbon	Gold
Line speed - cans per minute (CPM)	220	600
Standard equipment		
ATEX Zone 2 Leak Detector	•	•
Interface to customer PLC	•	•
Air preparation equipment	•	•
Automated line speed compensation		•
Configurable health system monitoring		•
Programmable alarms		•
Automated mirror cleaning		•
Reject verification		•
Performance options		
Standard (8×10^{-3} mBarLs ⁻¹)	•	•
Water bath alternative (2×10^{-3} mBarLs ⁻¹)	•	•

Specifications

Please consult Cascade if your requirements are outside the specifications listed below. Improved performance, other products, and material offerings may be available depending on the application.

IR source	Quantum Cascade Laser
Performance	
Sensitivity	Standard: 8×10^{-3} mBarL ⁻¹ Optional: 2×10^{-3} mBarL ⁻¹
Line speed	Up to 600 cans per minute
Can dimensions	Up to Height: 350 mm (14 in.), Diameter: 80 mm (3 in.), others on request
Response time	20 ms
Environmental	
Ambient temperature range	10 to 40 °C (50 to 104 °F)
Control console size	Height x Width x Depth: 1200 x 600 x 560 mm (47 x 24 x 22 in.)
Control console weight	70 kg (154 lb.)
Sensor head size	Height x Width x Depth: 590 x 330 x 330 mm (23 x 13 x 13 in.)
Sensor head weight	20 kg (44 lb.) - sensor only
Max factory air consumption	25 L/min approximately on regular usage
Factory compressed air pressure	8-10 bar, clean, dry, and oil free
Line space requirement	1.6 m (5.2 ft.) straight free line (maximum)
Utilities	
Air supply	25 L/min, 8-10 bar
System operating voltage	110 - 240 Vac 50 - 60 Hz, specify on order
System power consumption	1 kW maximum power requirement
Certifications	
Laser classification	Class 1 BS EN 60825-1: 2007 Safety of laser products Equipment classification and requirements (Identical to IEC 60825-1: 2007)
Hazardous area classification	Ex II 3G Ex nR II T6 ($10 \text{ °C} \leq T_{amb} \leq 40 \text{ °C}$)



Recommended Installation

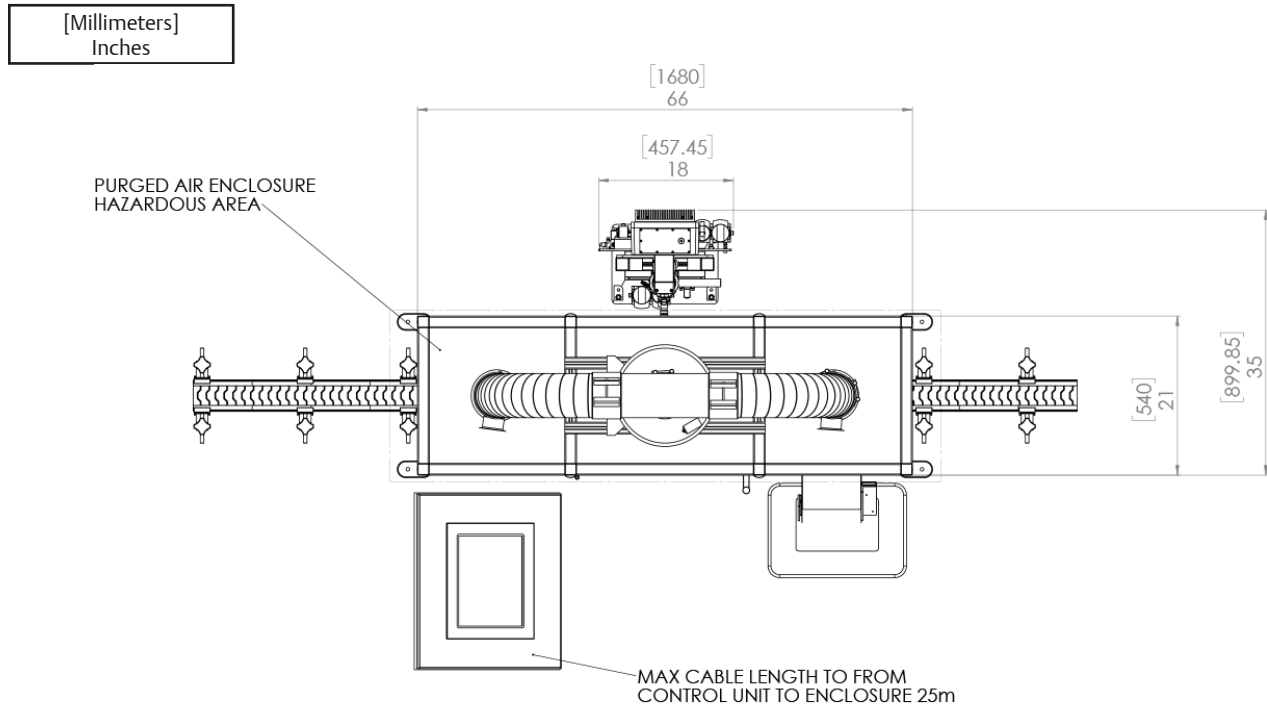

The drawing below represents the recommended production line layout for a typical aerosol filling line incorporating a CT2211 aerosol microleak detection system, in line with UN ADR requirements.

Figure 1 CT2211 Aerosol Microleak Detection System



EmersonProcess.com/GasAnalysis

 YouTube.com/user/RosemountAnalytical
 Twitter.com/Rosemount_News

 Analyticexpert.com
 Facebook.com/Rosemount

©2016 Emerson Process Management. All rights reserved.

The Emerson logo is a trademark and service mark of Emerson Electric Co. Cascade is a mark of one of the Emerson Process Management family of companies. All other marks are the property of their respective owners.

Emerson Process Management
 Cascade Technologies
 Glendevon House
 Castle Business Park
 Stirling, FK9 4TZ
 Scotland
 T + 44 1786 447 721
 F + 44 1786 475 822
 QCL.CSC@Emerson.com

The contents of this publication are presented for information purposes only, and while effort has been made to ensure their accuracy, they are not to be construed as warranties or guarantees, express or implied, regarding the products or services described herein or their use or applicability. All sales are governed by our terms and conditions, which are available on request. We reserve the right to modify or improve the designs or specifications of our products at any time without notice.