

HEAVY DUTY COMBO SHRINK SYSTEM



Specification Sheet

MODEL: HDX250

FEATURES

CONTROL PANEL

- Conveniently Positioned, **RS-5 Plus** Digital Controller with Three Year Warranty on Original Machine Controller
- Meets UL 508A Standard
- Simple Operation and Precise Temperature Controls
- Cycle Counter Comes Standard with Reset
- Single Cord 220V Single Phase Power Supply

SEALING AREA

- Hot Knife Exact Seal System with Multiple Profile Options
- Large 17" W by 21" L Seal Area
- Heavy Duty Cast Aluminum Seal Head with Stainless Film Clamps
- Balanced Magnetic Hold Down for Strong, Consistent Seals
- Seal Conveyor with Smooth Product Transfer from Seal Area to Tunnel

SHRINK TUNNEL

- Non-Stick Mesh Tunnel Belt with Adjustable Riser Bar for Improved Bottom Shrink
- Efficient MaxAir Tunnel Almost Triples the Airflow and Evenly Wraps Air Around Package
- Automatic Cool Down Extends Heating Element Life



HDX250

OTHER FEATURES

- Package Centering System for Even Shrink - Sealing and Tunnel Conveyor Move in Tandem Vertically. Also, Includes Tunnel Horizontal Quick Slide Adjustment.
- Two Year Warranty
- Four Individually Adjustable Perforating Wheels
- Auto Tensioning Film Cradle
- Heavy Duty Casters and Levelers

R HS Denotes RapidHS 5 Day Program Options

MODEL SPECS

FILM CAPACITY	22" Wide (56 cm)
L BAR SEALING AREA	17" W, 21" L (43 W, 53 L cm)
INSIDE TUNNEL DIMENSIONS	21" L, 16" W, 8" H (53 L, 41 W, 22 H cm)
TUNNEL CONVEYOR SPEED	0-20 Feet per Minute (0-6 meters per minute)
OVERALL DIMENSIONS	82" L, 32" W, 59" H (208 L, 82 W, 150 H cm)
WORKING HEIGHT	38" (97 cm)
POWER REQUIREMENTS	220 Volts, 23 Amp, Single Phase
TUNNEL WATTAGE	3,600
WEIGHT	800 lbs. (363 kg)

AVAILABLE OPTIONS

- Fully Stainless Steel Construction
- Added Heated Hole Punch
- Tunnel Belt Options: Stainless Steel Wire Mesh or PTFE Non-Stick Mesh **R HS**
- Left Hand Reverse Flow
- Spare Parts Kit (5820-012) **R HS**
- Powered Film Unwind with Perforating Roller and 6 Inch High Adjustable Inverting Head
- GTC180/16- 180 Degree Gravity Turn Around Conveyor
- GTC90/16- 90 Degree Gravity Turn Around Conveyor
- AT36- 36" Rotary Accumulator Table
- AT48- 48" Rotary Accumulator Table



HEAVY DUTY COMBO SHRINK SYSTEM



Specification Sheet

MODEL: HDX250

MACHINE FOOTPRINT

LENGTH (L)	82"
WIDTH (W)	32" Tunnel Retracted 40" Tunnel Pulled Out
HEIGHT (H)	59" Tunnel Lowers 4"

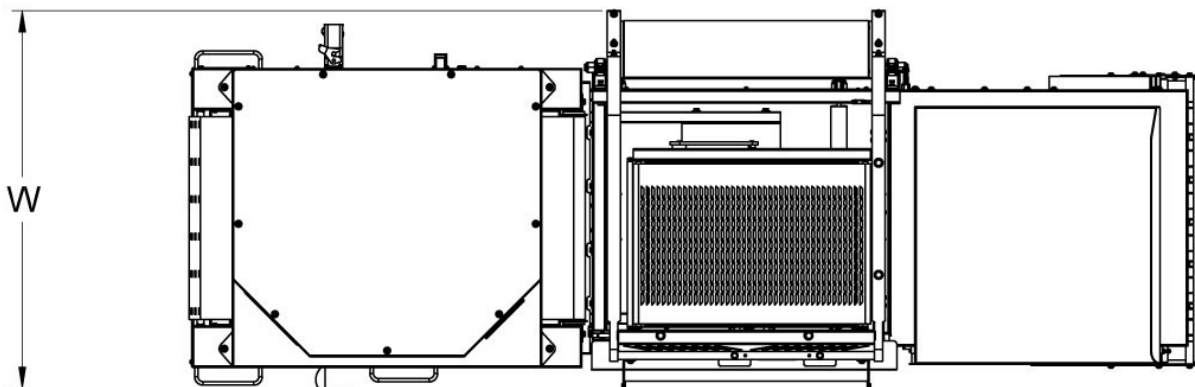
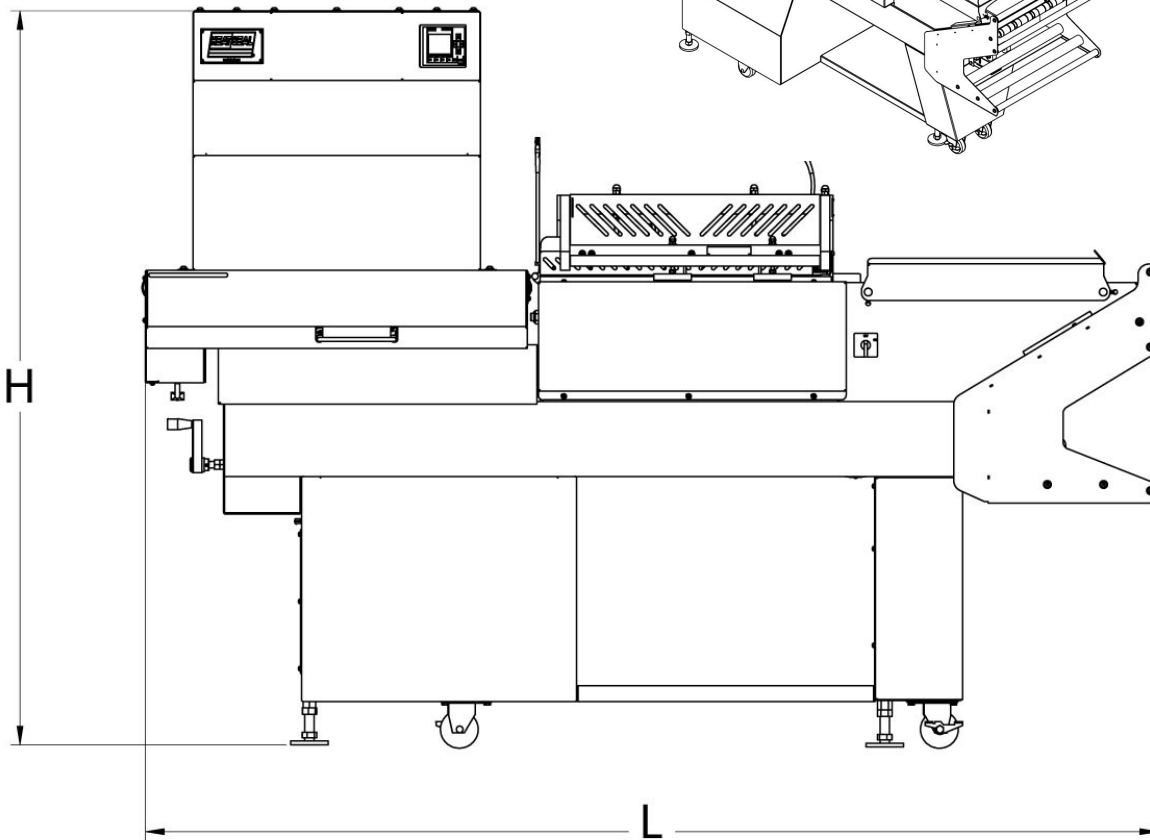
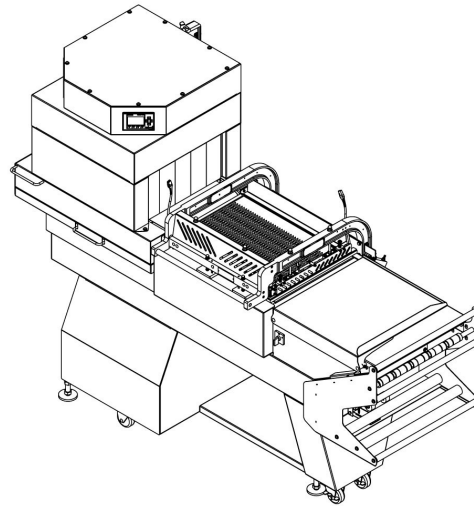

Revised 2021

4922 E. 49th Street, Suite 100, Cleveland, OH 44125
www.HeatSealCo.com

Phone: (216) 341-2022 Fax: (216) 341-2163
CustServ@HeatSealCo.com

