

Instruction Manual

XDS Dry Pump

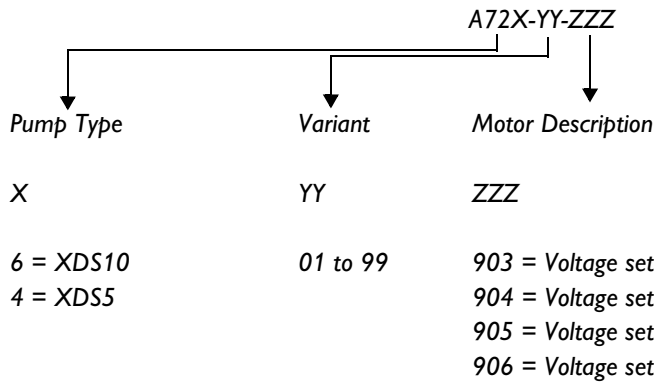

PDF Downloaded From

Ideal^{LLC}
vacuum products
(505) 872-0037

PLEASE NOTE: We do sell the related products within this literature but we are not connected in any way with the manufacture of your product. We provide this literature for the products we sell and service. They are intended to provide users with the manufactures instructions to operate the equipment in a safe manner.

www.idealvac.com



BOC EDWARDS

CE
98/37/EC
94/9/EC
89/336/EEC
73/023/EEC

Declaration of Conformity

We, BOC Edwards,
Manor Royal,
Crawley,
West Sussex RH10 2LW, UK

declare under our sole responsibility that the product(s):

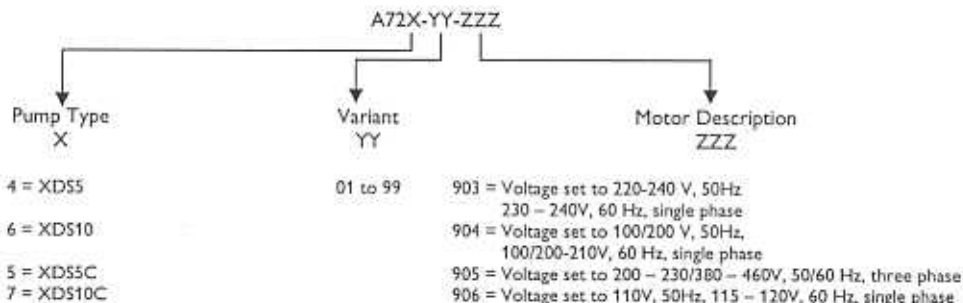

to which this declaration relates is in conformity with the following standard(s) or other normative document(s):

EN12100-2: 2003	Safety of Machinery: Basic Concepts, General Principles for Design.
IEC34 Parts 1, 5, 8, 11*	General Requirements for Rotating Electrical Machines.
EN1012-2: 1997	Compressors and Vacuum Pumps – Safety Requirements, Part 2.
EN61010-1: 2001*	Safety Requirements for Electrical Equipment for Measurement, Control and Laboratory Use.
C22.2 No1010.1.92*	Safety Requirements for Electrical Equipment for Measurement, Control and Laboratory Use. Part 1: General Requirements.
UL61010A-1*	Electrical Equipment for Laboratory Use. Part 1 General Requirements.
EN13463-1: 2001	Non Electrical Equipment for Potentially Explosive Atmospheres.

- * Three-phase pumps only.
- * Single-phase pumps only.
- * The pumps comply with the standard when installed in accordance with the instruction manuals supplied with the pump.

following the provisions of:

2006/95/EC	Low Voltage Directive.
2004/108/EC	Electromagnetic Compatibility Directive.
94/9/EC	Equipment for use in Potentially Explosive Atmospheres (ATEX Directive) (Category 3GD) Internal Atmospheres only.
98/37/EC	Machinery Safety Directive.



Barrie Brewster, Technical Manager
Burgess Hill Products

17th May 2007
BURGESS HILL
Date and Place

This product has been manufactured under a quality system registered to ISO9001

 **BOC EDWARDS**

CONTENTS

Section		Page
1	INTRODUCTION	1
1.1	Scope and definitions	1
1.2	ATEX directive implications	1
1.3	Description	3
1.4	Gas-ballast control	3
1.5	Construction	3
1.6	CSA Product classification	4
2	TECHNICAL DATA	5
2.1	Operating and storage conditions	5
2.2	Performance	5
2.2.1	General	5
2.2.2	Performance characteristics	5
2.3	Mechanical data	8
2.3.1	General	8
2.3.2	Noise and vibration data	8
2.4	Electrical data	8
2.4.1	Single-phase pumps	8
2.4.2	Three-phase pumps	8
2.5	Legislation and standards	8
3	INSTALLATION	11
3.1	Safety	11
3.2	System design considerations	11
3.3	Unpack and inspect	11
3.4	Lifting the pump	12
3.5	Locate the pump	12
3.6	Electrical installation: single-phase pumps	12
3.6.1	Check and configure the motor	12
3.6.2	Connect the pump to your electrical supply	13
3.6.3	Check the direction of rotation	13
3.7	Electrical installation: three-phase pumps	14
3.7.1	Check and configure the motor	14
3.7.2	Connect the pump to your electrical supply	14
3.7.3	Check the direction of rotation	15
3.8	Inlet and outlet connections	16
3.9	Leak test the system	16
4	OPERATION	17
4.1	Gas-ballast control	17
4.2	Start up procedure	17
4.3	To achieve ultimate vacuum	17
4.4	To pump condensable vapours	17
4.5	Implication of ATEX directive	18
4.5.1	Introduction	18
4.5.2	Flammable/pyrophoric materials	18

CONTENTS (continued)

Section		Page
4.5.3	Gas purges	18
4.6	Shut down	19
5	MAINTENANCE	21
5.1	Safety information	21
5.2	Maintenance plan	21
5.3	Inspect and clean the inlet strainer	22
5.4	Inspect and clean the gas-ballast control	22
5.5	Clean the external fan cover	22
5.6	Replace the tip seals	22
5.7	Test the motor condition	23
5.8	Fault-finding	23
5.8.1	The pump has failed to start	23
5.8.2	The pump has failed to achieve the required performance	24
5.8.3	The pump is noisy	24
5.8.4	The pump surface temperature is above 100 °C	24
5.8.5	The pumping speed is poor	25
6	STORAGE AND DISPOSAL	27
6.1	Storage	27
6.2	Disposal	27
7	SPARES AND ACCESSORIES	29
7.1	Introduction	29
7.2	Spares	29
7.3	Accessories	29
7.3.1	Solenoid operated pipeline valve	29
7.3.2	Gas-ballast adaptor	29
7.3.3	Vibration isolators	29
7.3.4	Exhaust nozzle kit	29
7.3.5	XDS silencer	29
	INDEX	31

ILLUSTRATIONS

Figure		Page
1	The single-phase XDS dry pump	2
2	Performance characteristics	6
3	Dimensions	7
4	Electrical interface: single-phase pumps	12
5	Underside of the pump	14
6	Three-phase electrical connections: 200-230 V	14
7	Three-phase electrical connections: 380-460 V	14
8	Inlet strainer assembly	22
9	Gas-ballast control assembly	23
10	Replacing the tip seals	24

TABLES

Table		Page
1	General characteristics	5
2	Performance characteristics	6
3	Dimensions (mm)	7
4	Electrical data (single-phase pumps with item numbers -903 or -906)	9
5	Electrical data (single-phase pumps with item numbers -904)	9
6	Electrical data (three-phase pumps with item numbers -905)	9
7	Wire colour codes	13
8	Maintenance plan	21
9	Solenoid operated pipeline valve	29

This page intentionally blank.

1 INTRODUCTION

1.1 Scope and definitions

This manual provides installation, operation and maintenance instructions for the BOC Edwards XDS5 and XDS10 dry pumps. You must use the XDS pump as specified in this manual. Read this manual before you install, operate and maintain the XDS pump.

Important safety information is highlighted as WARNING and CAUTION instructions; you must obey these instructions. The use of WARNINGS and CAUTIONS is defined below.

	WARNING
Warnings are given where failure to observe the instruction could result in injury or death to people.	

CAUTION
Cautions are given where failure to observe the instruction could result in damage to the equipment, associated equipment and process.

Throughout this manual, page, figure and table numbers are sequential.

The units used throughout this manual conform to the SI international system of units of measurement.

Pressures are stated as absolute pressures throughout this manual, unless otherwise stated.

The following IEC warning labels appear on the pump:



Warning - refer to accompanying documentation.



Warning - risk of electric shock.



Warning - hot surfaces.

1.2 ATEX directive implications

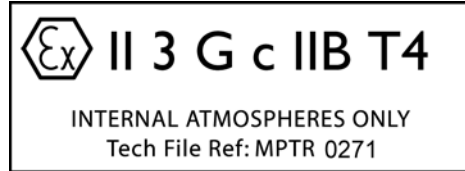

- This equipment is designed to meet the requirements of Group II Category 3 equipment in accordance with Directive 94/9/EC of the European Parliament and the Council of 23rd March 1994 on the approximation of the laws of the Member States concerning equipment and protective systems intended for use in potentially explosive atmospheres. (The ATEX Directive)

The ATEX Category 3 applies in respect of potential ignition sources internal to the equipment. An ATEX Category has not been assigned in respect of potential ignition sources on the outside of the equipment as the equipment has not been designed for use where there is an external potentially explosive atmosphere.

There is no potential source of ignition within the pump during normal operation but there may be potential sources of ignition under conditions of predicted and rare malfunction as defined in the Directive. Accordingly, although the pump is designed to pump flammable materials and mixtures, operating procedures should ensure that under all normal and reasonably predicted conditions, these materials and mixtures are not within explosive limits. Category 3 is considered appropriate for the avoidance of ignition in the case of a rare malfunction which allows flammable materials or mixtures to pass through the pump while within their explosive limits.



- | | |
|----------------------------|----------------------|
| 1. NW25 inlet port | 5. Baseplate |
| 2. Gas-ballast control | 6. Voltage indicator |
| 3. Cooling fan | 7. On / off switch |
| 4. DN25NW/3/4" BSP exhaust | 8. Hour counter |

Figure 1 - The single-phase XDS dry pump

XDS Dry Pump

- When flammable materials are present within the equipment you must:
 - Not allow air to enter the equipment.
 - Ensure the system is leak tight

For further information, please refer to the back page of this instruction manual for the contact details of your nearest BOC Edwards.

1.3 Description

The XDS pump is shown in Figure 1. Refer to Figure 1 for item numbers in brackets in the following descriptions.

The XDS pump is a compact, reliable vacuum pump which is suitable for use on vapour handling processes. The XDS pump may be used for some pumping applications involving corrosive substances and particulates; for information on pumping flammable gases, please refer to Section 4.5 and contact BOC Edwards for any further assistance.

The body of the pump includes a fixed scroll and an orbiting scroll. The orbiting scroll is driven by the electric motor through an eccentric cam on the motor drive shaft. The movement of the orbiting scroll, meshed with the fixed scroll, forms successive crescent shaped volumes in the pump. Gas which enters the pump through the inlet is compressed by the movement of the orbiting scroll and swept towards the centre of the fixed scroll. The compressed gas enters the exhaust port near the centre of the stationary scroll and is exhausted from the pump through the outlet.

The XDS pump is a dry vacuum pump, as all the bearings, with their hydrocarbon lubricant, are isolated from the vacuum space.

The inlet of the pump is fitted with a removable inlet strainer which prevents the entry of debris into the pump.

The pump mechanism is driven directly by a single-phase or three-phase electric motor. Single-phase motors are fitted with an on/off switch (7) and a thermal overload device. When the motor is too hot, the thermal overload device switches off the pump. The thermal overload device has an automatic reset; when the motor cools down, the device resets and (unless you have incorporated suitable control equipment which must be manually reset), the motor will restart.

The pump is air-cooled by a fan mounted at the opposite end to the motor.

The pump is mounted on a baseplate on rubber feet. Details of suitable vibration isolators and other accessories are provided in Section 7.

1.4 Gas-ballast control

To pump high vapour loads, gas-ballast is delivered into the pump to prevent condensation of the vapour carried by the pumped gases.

Air can be introduced to the low vacuum stages through the gas-ballast valve. Alternatively, an inert gas such as nitrogen can be supplied through a suitable external valve.

The gas-ballast control has three-positions:

- Closed (position '0')
- Low flow (position 'I')
- High flow (position 'II')

1.5 Construction

The pump scrolls are made from anodised aluminium and the motor housing made from aluminium only. All surfaces of the pump which are exposed to the pumped gases are free from copper, zinc and cadmium.

1.6 CSA Product classification

Type of protection against electric shock	Class 1
Supply connection	110-120 V, 50/60 Hz or 220-240 V, 50/60 Hz
Mode of operation:	Continuous
Protection against hazards of explosion	Not protected
Protection against ingress of liquids	Not protected (IPXO)
Installation category	II
Pollution degree	2
Degree of mobility	Portable (bench mounted)

2 TECHNICAL DATA

2.1 Operating and storage conditions

Ambient temperature:

Operating range 10 °C to 40 °C

Storage range -30 °C to 70 °C

Surface temperature of pump above ambient (when operating at ultimate) typically 45 °C

Maximum humidity (operation) 90%

Altitude up to 2000 m

2.2 Performance

2.2.1 General

General characteristics of the pumps are defined in Table 1 below. Characteristics shown are displacement, pumping speed and maximum permitted interface pressures.

Suckback on pump switch off typically 30 mbar ls⁻¹ (leak tightness 1x10⁻⁶ mbar ls⁻¹).

2.2.2 Performance characteristics

The position of the gas-ballast control defines the performance characteristics of the pump. These performance characteristics are listed fully in Table 2.

The curves shown in Figure 2 show the relationship between inlet pressure and pumping speed for the pump.

	XDS 10	XDS 5
Maximum displacement (m ³ /hr) 50 Hz electrical supply 60 Hz electrical supply	11.3 13.4	5.7 6.7
Maximum pumping speed (m ³ /hr) Pneurop 6602 (1979) 50 Hz electrical supply 60 Hz electrical supply	9.3 11.1	4.8 6.0
Maximum permitted inlet pressure and gas-ballast inlet pressure	0.5 bar gauge	0.5 bar gauge
Maximum permitted outlet pressure	1 bar gauge	1 bar gauge

Table 1 - General characteristics

XDS Dry Pump

Parameter	Units	XDS 10	XDS 5
Gas-ballast control closed (position '0') typical ultimate vacuum (total pressure) 50 Hz	mbar Pa	$< 7 \times 10^{-2}$ < 7	$< 7 \times 10^{-2}$ < 7
typical ultimate vacuum (total pressure) 60 Hz	mbar Pa	$< 6 \times 10^{-2}$ < 6	$< 6 \times 10^{-2}$ < 6
Gas-ballast control closed (position '1') typical ultimate vacuum (total pressure) 50 Hz	mbar Pa	1.5×10^{-1} 15	1.5×10^{-1} 15
typical ultimate vacuum (total pressure) 60 Hz	mbar Pa	1.2×10^{-1} 12	1.2×10^{-1} 12
Gas-ballast flow	l / min	3	3
water vapour pumping capacity	g / hr	70	70
Gas-ballast control closed (position '2') typical ultimate vacuum (total pressure) 50 Hz	mbar Pa	3.5×10^{-1} 35	3.5×10^{-1} 35
typical ultimate vacuum (total pressure) 60 Hz	mbar Pa	3×10^{-1} 30	3×10^{-1} 30
Gas-ballast flow	l / min	15	15
water vapour pumping capacity	g / hr	> 200	> 200
water vapour tolerance	mbar Pa	35 5×10^3	50 3.5×10^3

Table 2 - Performance characteristics

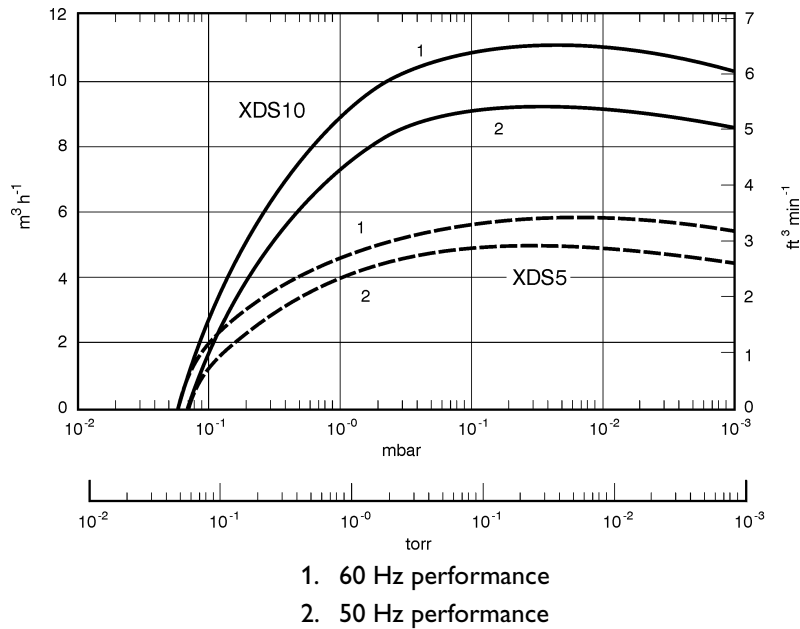
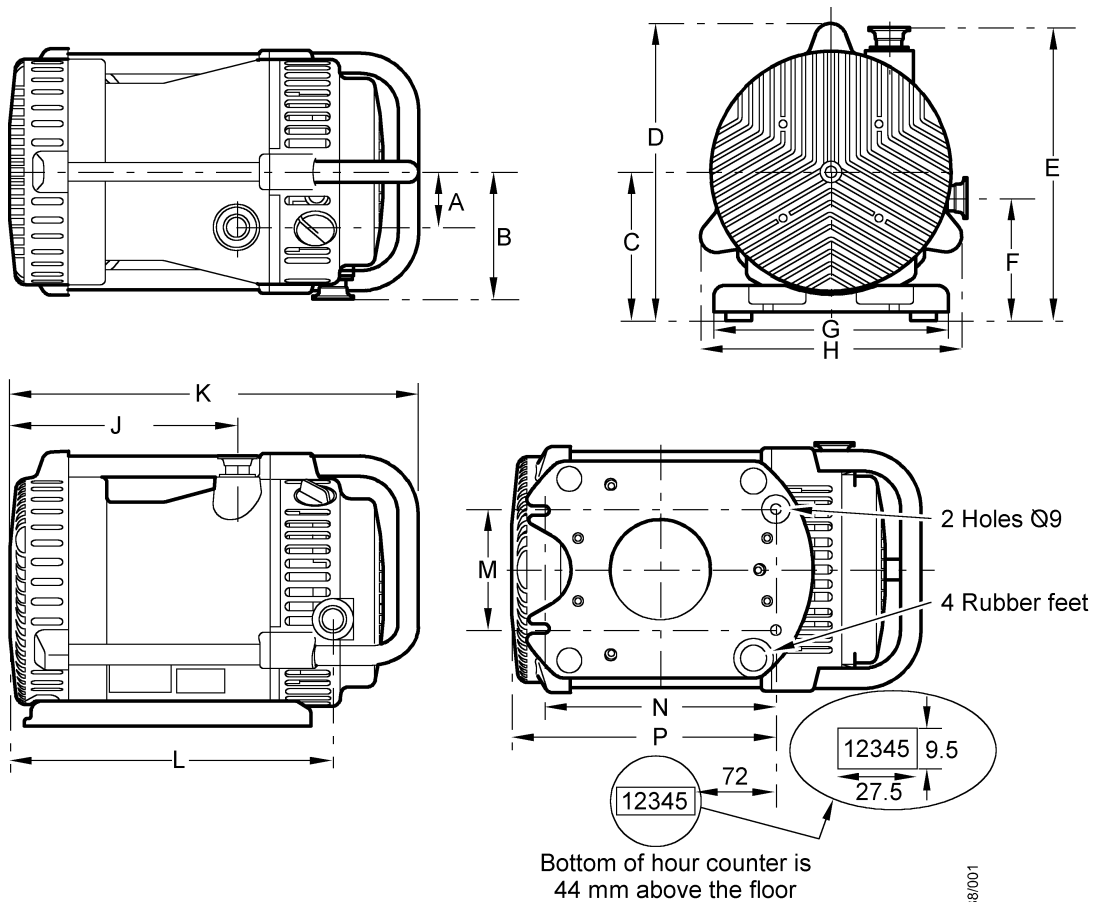

Figure 2 - Performance characteristics

XDS Dry Pump



dcs/0188/001

from motor end to centre of single phase socket = 200 mm
 from motor end to centre on/off = 124 mm
 Refer to Table 3 for dimensions

Figure 3 - Dimensions

Dimension Reference (Refer to Figure 3)	XDS5	XDS10
A =	55	55
B =	135	135
C =	147	147
D =	290	290
E =	288	288
F =	133	133
G =	220	220
H =	249	249
J =	210	210
K =	427	427
L =	297	315
M =	120	120
N =	230	230
P =	275	275

Table 3 - Dimensions (mm)

2.3 Mechanical data

2.3.1 General

Maximum tilt angle	10°
Motor rotational speed (50 Hz supply)	1440 rpm
Motor rotational speed (60 Hz supply)	1730 rpm
Mass (kg)	XDS5=23 XDS10=24.5
Inlet / outlet connections	DN25NW
Overall dimensions (mm)	427x290x249

2.3.2 Noise and vibration data

Sound pressure measured at ultimate vacuum pump to ISO 11201	55 dB(A) at 1 m
Vibration: measured at the inlet port to ISO 10816-1: 1995	Class 1C <4.5 mms ⁻¹ (rms)

2.4 Electrical data

2.4.1 Single-phase pumps

The dual voltage, dual frequency motor is designed for a single-phase electrical supply and is suitable for 50 Hz or 60 Hz operation (refer to Tables 4 and 5 for the electrical data). The motor can be manually switched between nominal supply voltages of 110-120 V and 220-240 V (refer to Section 3.6).

2.4.2 Three-phase pumps

The dual voltage, dual frequency motor is designed for a three-phase electrical supply and is suitable for 50 Hz or 60 Hz operation (refer to Table 6 for the electrical data). The motor can be manually switched between nominal supply voltages of 220-240 V and 380-460 V electrical supplies (refer to Section 3.7). Pumps are supplied pre-set to 380-460 V electrical supplies.

2.5 Legislation and standards

The standards and legislation with which the XDS pump complies are listed in full on the Declaration of Conformity on the inside cover of this manual.

XDS Dry Pump

Pump	Nominal Supply (V)	Frequency (Hz)	Power (W)	Current (A)	Recommended Fuse Rating (A)
XDS5 and XDS10	220 - 240	50	250	3.6	5
	230 - 240	60	300	3.2	5
	110	50	250	7.2	10
	115 - 120	60	300	6.4	10

Table 4 - Electrical data (single-phase pumps with item numbers -903 or -906)

Pump	Nominal Supply (V)	Frequency (Hz)	Power (W)	Current (A)	Recommended Fuse Rating (A)
XDS5 and XDS10	200	50	250	4	5
	200 - 210	60	300	3.7	5
	100	50	250	8	10
	100	60	300	7.5	10

Table 5 - Electrical data (single-phase pumps with item numbers -904)

Pump	Nominal Supply (V)	Frequency (Hz)	Power (W)	Current (A)	Recommended Fuse Rating (A)
XDS5 and XDS10	200 - 230	50	250	1.77	5
	200 - 230	60	300	1.80	5
	380 - 415	50	250	0.96	3
	400 - 460	60	300	1.00	3

Table 6 - Electrical data (three-phase pumps with item numbers -905)

This page intentionally blank.

3 INSTALLATION

3.1 Safety

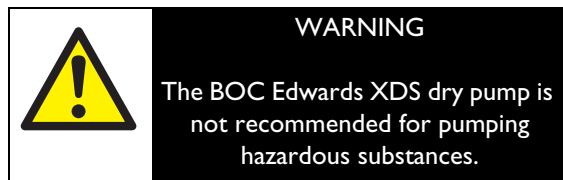

You must ensure that the XDS pump is suitable for your application. If you have any doubt about the suitability of the XDS pump for your application, refer to the BOC Edwards guidelines on vacuum pump and vacuum system safety (see associated publications at the end of the contents list at the front of this manual).

The installation of the XDS pump must be performed by a suitably trained and supervised technician. Obey the safety instructions listed below when you install the XDS pump, especially when you connect the pump into an existing system. Details of the specific safety precautions are given at the appropriate point in the instructions.

- Wear the appropriate safety clothing when you come into contact with contaminated components. Dismantle and clean contaminated components inside a fume cupboard.
- Vent and purge your vacuum system before you start installation work.
- Ensure that the installation technician is familiar with the safety procedures which relate to the products handled by the pumping system.
- Disconnect the other components in the pumping system from the electrical supply so that they cannot be operated accidentally.

3.2 System design considerations

Consider the following points when you design your pumping system:

Use a suitable valve to isolate the pump from your vacuum system if you need to allow the pump to warm up before pumping condensable vapours or if you need to maintain vacuum when the pump is switched off.

Avoid high levels of heat input into the pump from the process gases, otherwise the pump may overheat and seize, and cause the motor thermal overload device to open.

If you use the pump in a high ambient temperature and have a high gas throughput, the temperature of the pump body may exceed 100 °C and you must fit suitable guards to prevent contact with hot surfaces.

Make sure that the exhaust pipeline cannot become blocked. If you have an exhaust isolation valve, make sure that you cannot operate the pump with the valve closed.

3.3 Unpack and inspect

Remove all packing materials, remove the pump from its packing box, remove the protective covers from the inlet and outlet ports and inspect the pump. If the pump is damaged, notify your supplier and the carrier in writing; state the item number of the pump together with your order number and your supplier's invoice number. Retain all the packing materials for inspection. Do not use the pump if it is damaged.

If the pump is not to be used immediately, replace the protective covers. Store the pump in suitable conditions, as described in Section 6.1.

3.4 Lifting the pump

Although the pump is less than 25 kg and can be lifted manually, it is recommended that suitable lifting equipment is used whenever possible. The lifting equipment should be attached to the uppermost tri-bar on the pump. It should be noted that the pump may alter its position during lifting and suitable precautions should be taken.

3.5 Locate the pump

Provide a firm, level platform for the pump. Locate the pump so that the gas-ballast control and the on / off switch are accessible.

If your pump will be located inside an enclosure, make sure that there is adequate ventilation at both ends of the pump, so that the ambient temperature around the pump does not exceed 40 °C. There must be a minimum space of 25 mm between the pump and the enclosure walls.

In addition, ensure that the location of the pump and the intended routing of connecting parts i.e. process line, exhaust line and power cables will not present any physical hazards, for example; trip hazards to personnel.

3.6 Electrical installation: single-phase pumps

3.6.1 Check and configure the motor

CAUTION

Ensure that the motor is correctly configured for your electrical supply. If you operate the pump when the motor is not correctly configured for the electrical supply, you will damage the motor.

Refer to Figure 4 for the item numbers in brackets.



1. On/off switch (I = on, O = off)
2. Voltage indicator moulding
3. Cable socket
4. Voltage selector screws
5. Voltage indicator arrow

Figure 4 - Electrical interface: single-phase pumps

XDS Dry Pump

Ensure that the voltage shown on the voltage indicator (5) on the motor cover corresponds with your electrical supply voltage. If it does not, you must change the configuration of the pump motor to match your supply voltage; use the procedure below.

1. Undo the two screws (4) and lift off the voltage indicator moulding (2).
2. Rotate the voltage indicator moulding (2) so that the correct voltage is next to the arrow (5) on the terminal box cover.
3. Replace the two screws (4).

3.6.2 Connect the pump to your electrical supply

	<p style="text-align: center; margin: 0;">WARNING</p> <p style="text-align: center; margin: 0;">Ensure that the electrical installation of the XDS pump conforms with your local and national safety requirements. It must be connected to a suitably fused and protected electrical supply and a suitable earth point.</p>
--	--

Make the electrical connections to the pump motor with an IEC 320 cable socket (cold condition type) that satisfies your local electrical standards. A range of suitable cables are available from your supplier or BOC Edwards.

The pump must be connected to a suitable fused and protected electrical supply and a suitable earth point.

If your XDS pump was supplied with an electrical supply cable, the cable will be fitted with a moulded IEC connector at one end. The other end of the cable may be fitted with a plug suitable for your local electrical supply. A cable without a plug will contain wires colour coded as follows:

1. Ensure that the on /off switch on the motor is in the 'off' position.

2. Insert the moulded IEC connector at the end of the cable into the electrical inlet connector on the motor.

Convention	Earth	Neutral	Live
Europe	green and yellow	blue	brown
USA	green	white	black

Table 7 - Wire colour codes

3. Connect the plug (if fitted) at the other end of the cable to your electrical supply. If a plug is not fitted, connect the wires in the cable to the correct terminals of your electrical supply.

3.6.3 Check the direction of rotation

<p style="text-align: center; margin: 0;">CAUTION</p> <p style="text-align: center; margin: 0;">Ensure that the pump motor rotates in the correct direction. If it does not, turn the pump and your vacuum system can become pressurised.</p>
--

1. Remove the plastic cover over the screw in the centre of the motor back plate.
2. Use the on / off switch to switch on the electrical supply to the motor for a few seconds.
3. Check that the screw on the back of the motor rotates in the correct direction, shown by the arrow on the motor. If the direction of rotation is incorrect, switch off the electrical supply immediately and contact your supplier or BOC Edwards for advice.

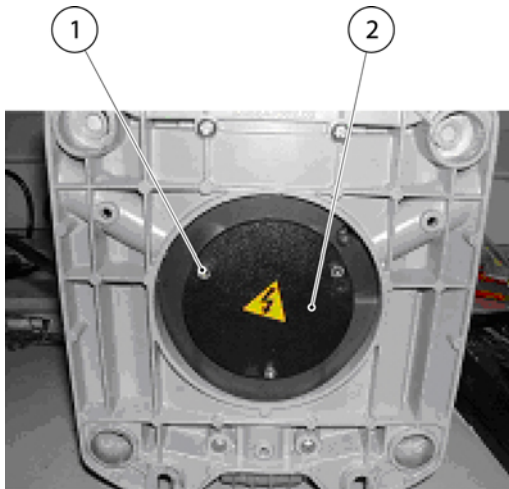

1. Screws
2. Access plate

Figure 5 - Underside of the pump

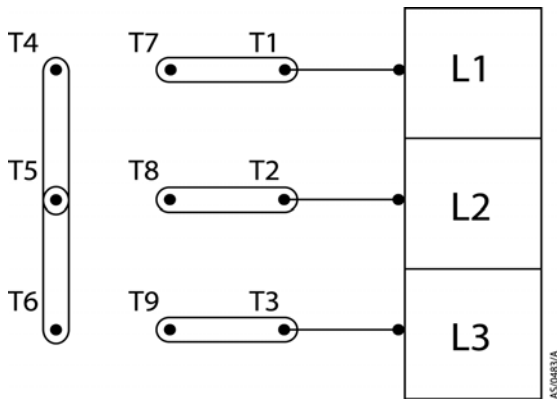

Figure 6 - Three-phase electrical connections: 200-230 V

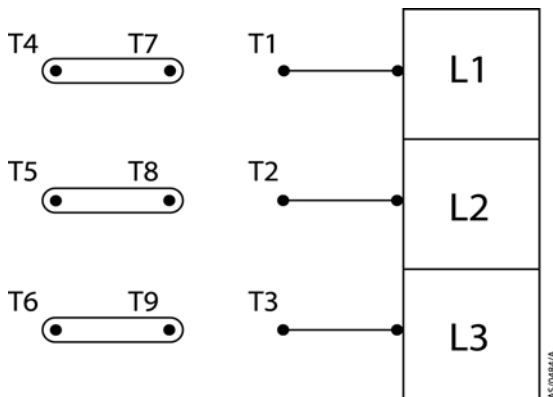

Figure 7 - Three-phase electrical connections: 380-460 V

3.7 Electrical installation: three-phase pumps

3.7.1 Check and configure the motor

CAUTION

Ensure that the motor is configured correctly for your electrical supply. If you operate the pump when the motor is not configured correctly for the electrical supply, you will damage the motor.

CAUTION

Power cable rated at 70°C must be used to connect the 3 phase pump to the power supply. Failure to do so may result in cable damage if the pump is used in high ambient temperatures.

1. Place the pump on its back, exposing the underside of the pump (refer to Figure 5). Undo the 3 screws securing the access plate and remove it.
2. Ensure that the motor is correctly configured for your electrical supply. If necessary reconfigure the links (refer to Figures 6 and 7) to suit your electrical supply.
 - For 200 - 230 V electrical supplies the links must be configured as shown in Figure 6.
 - For 380 - 460 V electrical supplies the links must be configured as shown in Figure 7.

3.7.2 Connect the pump to your electrical supply



WARNING

Ensure that the electrical installation of the XDS pump conforms with your local and national safety requirements. It must be connected to a suitably fused and protected electrical supply and a suitable earth point.



WARNING

If the pump is to be used on the floor of a work area, position the power lead and the exhaust and inlet hoses with care. Ensure that personnel in the area are aware of any obstructions around the pump.

The electrical supply cable to the 3-phase pump is permanently attached to the pump. Ensure that it is routed such that it cannot be snagged or become a tripping hazard.

Note: To prevent automatic restart of the pump-motor if the electrical supply is restored after an electrical supply failure, connect the pump to the electrical supply through suitable control equipment which must be reset manually after an electrical supply failure.

Note: To maintain compliance with CSA (Canadian Standards Association) standards, you must incorporate a switch or circuit breaker in the pump electrical supply. The switch or circuit breaker must be close to the pump and easily accessible, and must be clearly marked to identify that it is the electrical supply disconnection device for the pump.

We recommend that you connect the electrical supply to the motor through a starter or circuit breaker which has thermal over-current protection which can be adjusted to suit the current ratings shown in Table 6. The fuse ratings in Table 6 are provided for guidance only. The supplier of your thermal over-current protection device may specify different values to ensure correct operation of the fuse and the over-current protection device.

Note: The following instructions refer to connecting a cable to the terminal block within the terminal box. If the unit is already fitted with a cable, please ignore these instructions but retain them in the event the cable ever needs replacement. It is still necessary to check the direction of rotation.

The diameter of the electrical supply cable should be in the range 7 to 11 mm. The cable must conform in size and colour coding with your local and national electrical installation regulations.

1. Pass the electrical supply cable through the cable-gland and out of the access hole.
2. Use insulated crimped connectors to connect the wires in the cable to the terminals U1, V1, W1 and earth in the terminal-box as shown in Figures 6 and 7. Ensure connections are made using plain washer, spring washer and nut, in that order.
3. Refit the access plate.
4. Tighten the strain-relief nut on the cable-gland.

3.7.3 Check the direction of rotation

CAUTION

Ensure that the pump motor rotates in the correct direction. If it does not, the pump and your vacuum system can become pressurised.

1. Unscrew the 3 retaining screws and remove the plastic cover in the centre of the motor back plate.
2. Switch on the electrical supply to the motor for a few seconds.
3. Check that the screw on the back of the motor rotates in the correct direction, shown by the arrow on the motor.
4. If the direction of rotation is incorrect, switch off the electrical supply and isolate the pump from the electrical supply. Disassemble the plug and switch the positions of the black wires.

3.8 Inlet and outlet connections

	<p>WARNING</p> <p>Connect the exhaust to a suitable treatment plant to prevent the discharge of dangerous gases and vapours to the surrounding atmosphere.</p>
---	---

Before you connect the pump to your vacuum system, fit the centring ring and inlet strainer (supplied with the pump) to the pump inlet port. Ensure that debris does not get into your pump when you install it.

Take note of the following information when you connect the pump to your vacuum system. Refer to Section 7 for details of the accessories mentioned below. Use standard DN25NW fittings (not supplied) when you connect the pump.

For maximum pumping speeds, ensure that the pipeline connected to the pump inlet is as short as possible and has an internal diameter of 25 mm or larger.

- Support the vacuum pipeline to prevent loading of the coupling joints.
- If necessary, incorporate flexible pipeline in your system to reduce the transmission of vibration and to prevent loading of the coupling joints. If you use flexible bellows, you must ensure that you use bellows which have a maximum pressure rating which is greater than the highest pressure that can be generated in your system.
- In some applications e.g. when backing a turbomolecular pump, we recommend that you incorporate an inlet isolation valve in the pipeline from the vacuum system to the pump, so that you can isolate the vacuum system from the pump when it is switched off.
- Ensure that the sealing surfaces are clean and scratch-free.

We recommend that you use an exhaust extraction system suitable for use with all of the process gases you will pump. Ensure that the exhaust extraction system cannot become blocked or obstructed when the pump is operating. Use a catchpot on the exhaust to prevent the drainage of contaminated condensation back into the pump.

A small amount of tip seal wear product may collect in the exhaust duct of the pump. The dust may be blown out with the initial burst of air after the pump has been vented. This is quite common and the amount of dust seen will reduce over time.

<p>CAUTION</p> <p>At high temperature (in excess of 250 °C) tip seal wear product will begin to decompose, giving rise to gaseous fumes that can produce unpleasant symptoms.</p>
--

3.9 Leak test the system

Leak test the system and seal any leaks found after you have installed the XDS pump, to prevent leakage of any substances out of the system and leakage of air into the system.

4 OPERATION

4.1 Gas-ballast control

You can use the gas-ballast control to optimise the performance of the dry pump for your application. The performance characteristics of the pump with the different ballast settings are shown in Table 2. You can change the position of the gas-ballast control when the pump is off or when the pump is operating.

Use the gas-ballast control to change the amount of air introduced into the low vacuum stages of the pump. Use of gas-ballast will prevent the condensation of vapours in the pump; the condensates would contaminate the pump. You can turn the gas-ballast control to select one of the three positions, as follows:

To close the gas-ballast, turn the control to position '0'. Use this setting:

- to achieve ultimate vacuum
- to pump dry gases.

To select low flow gas-ballast, turn the control to position 'I'. Use this setting:

- to pump condensable vapours
- to dilute process gases if required.

To select high flow gas-ballast, turn the control to position 'II'. Use this setting:

- to pump high concentrations of condensable vapours
- to dilute process gases if required
- to clear excess vapours after processing.

4.2 Start up procedure

	WARNING
Ensure that your system design does not allow the exhaust pipeline to become blocked.	

CAUTION
A fine dust may be emitted from the exhaust of the scroll pump during start up, particularly when the pump is new or if new tip seals are fitted. Refer to Section 5.6 for further information when fitting new tip seals.

Use the procedure below to start up the pump:

1. Ensure that any vacuum system isolation valve is closed.
2. Switch on the electrical supply to the pump, using the on / off switch on the motor.
3. Open any vacuum system isolation valve.

4.3 To achieve ultimate vacuum

To close the gas-ballast, turn the control to position '0'. Use this setting in order to achieve the best possible vacuum. If the pump has been used to pump condensable vapours or is to pump a large chamber that has been exposed to atmospheric air (water vapour), it may be necessary to run for at least an hour on high flow gas-ballast 'II'.

4.4 To pump condensable vapours

Use gas-ballast (ballast knob set to I or II) when there is a significant proportion of condensable vapours in the process gases. The pump should be up to full operating temperature prior to exposure to condensable vapours.

4.5 Implication of ATEX directive

4.5.1 Introduction

This equipment is designed to meet the requirements of Group II Category 3 equipment in accordance with Directive 94/9/EC of the European Parliament and the Council of 23rd March 1994 on the approximation of the laws of the Member States concerning equipment and protective systems intended for use in potentially explosive atmospheres. (The ATEX Directive)

The ATEX Category 3 applies in respect of potential ignition sources internal to the equipment. An ATEX Category has not been assigned in respect of potential ignition sources on the outside of the equipment as the equipment has not been designed for use where there is an external potentially explosive atmosphere.

There is no potential source of ignition within the pump during normal operation but there may be potential sources of ignition under conditions of predicted and rare malfunction as defined in the Directive. Accordingly, although the pump is designed to pump flammable materials and mixtures, operating procedures should ensure that under all normal and reasonably predicted conditions, these materials and mixtures are not within explosive limits. Category 3 is considered appropriate for the avoidance of ignition in the case of a rare malfunction which allows flammable materials or mixtures to pass through the pump while within their explosive limits.

4.5.2 Flammable/pyrophoric materials

	<p>WARNING</p> <p>The following precautions and actions must be obeyed to ensure gas being pumped stays out of the flammable range.</p>
---	--

When flammable or pyrophoric materials are present within the equipment you must:

- Not allow air to enter the equipment
- Ensure the system is leak tight.
- Use an inert gas purge (for example, a nitrogen purge) to dilute any flammable gases or vapours entering the pump inlet, and/or use an inert gas purge to reduce the concentration of flammable gases or vapours in the pump and in the exhaust pipeline to less than one quarter of the gases' published Lower Explosive Limits (LEL).
- Use an inert gas purge in to the pump gas ballast connection to prevent the condensation of flammable vapours within the pump mechanism and exhaust pipeline.

4.5.3 Gas purges

	<p>WARNING</p> <p>If you use inert gas purge to dilute dangerous gases to a safe level, ensure that the XDS pump is shut down if an inert gas supply fails.</p>
---	--

	<p>WARNING</p> <p>You must obey the instructions and take note of the precautions given below, to ensure that pumped gases do not enter their flammable ranges.</p>
---	--

Switch on the inert gas purge to remove air from the pump and the exhaust pipeline before the process starts. Switch off the purge flow at the end of the process only after remaining flammable gases or vapours have been purged from the pump and exhaust pipeline.

If liquids that produce flammable vapours could be present in the pump foreline then the inert gas purge to the XDS pump should be left on all the time this liquid is present. Flammable liquids could be present in the foreline as a result of condensation or may be carried over from the process.

When calculating the flow rate of inert gas required for dilution, consider the maximum flow rate for the flammable gases/vapours that could occur. For example, if a mass flow controller is being used to supply flammable gases to the process, you should assume a flow rate for flammable gases that could arise if the mass flow controller is fully open.

Continually measure the inert gas purge flow rate: if the flow rate falls below the required, you must stop the flow of flammable gases or vapours into the pump.

We recommend you obtain and read Vacuum Pump and Vacuum System Safety (publication number P300-20-000), available from BOC Edwards or your supplier.

4.6 Shut down

Use the procedure below to shut down the pump:

1. If shutting the pump down prior to a period of storage, remove any process gases by running on high flow gas-ballast.
2. Close the vacuum system isolation valve to prevent suckback into the vacuum system (where fitted).
3. Switch off the pump using the on/off switch on the motor.

This page intentionally blank.

5 MAINTENANCE

5.1 Safety information

	<p>WARNING</p> <p>Obey the safety instructions given below and take note of appropriate precautions. If you do not, you can cause injury to people and damage to equipment.</p>
---	--

The XDS pump is designed to require little user maintenance. Observe the following guidelines when carrying out maintenance on your pump:

- Ensure that maintenance is done by a suitably trained and supervised technician. Obey your local and national safety requirements.
- Ensure that the maintenance technician is familiar with the safety procedures which relate to the products processed by the pumping system.
- Check that all the required parts are available and are of the correct type before you start work.
- Isolate the pump and other components from the electrical supply so that they cannot be operated accidentally.
- Allow the pump to cool (so that it is at a safe temperature for skin contact) before you start maintenance work. Make sure that the pump is switched off in case the thermal overload device restarts the pump.
- Do not re-use internal 'O' rings.

- The pump will be contaminated with the process chemicals that have been pumped during operation. Ensure that the pump is decontaminated before maintenance and that you take adequate precautions to protect people from the effects of dangerous substances if contamination has occurred.
- Do not touch or inhale the thermal breakdown products of fluorinated materials which may be present in the pump if the pump has been heated to 260 °C and above. Fluorinated materials are safe in normal use but can decompose into very dangerous substances (which may include hydrofluoric acid) if they are heated to 260 °C and above. The pump may have overheated if it was misused or if it was in a fire. Health and Safety Data sheets for fluorinated materials used in the pump are available on request: contact your supplier or BOC Edwards.

5.2 Maintenance plan

More frequent maintenance may be required if the pump is used to pump aggressive gases and vapours, such as solvents, organic substances and acids, or if the pump is operated continuously at the higher end of its operating temperature, refer to Section 2.1. If necessary, adjust the maintenance plan according to your experience.

Operation	Frequency	Refer to Section
Inspect and clean inlet strainer	Annually	5.3
Inspect and clean the gas-ballast control	Annually	5.4
Clean the external fan cover	Annually	5.5
Replace the tip seals and exhaust valve	Annually or as required	5.6
Test the motor condition	15000 hours	5.7
Replace the bearings	35000 hours	contact BOC Edwards

Table 8 - Maintenance plan

5.3 Inspect and clean the inlet strainer

Whenever you disconnect the pump from your vacuum system, we recommend that you:

- Remove any debris trapped by the inlet strainer (in the inlet port).
 - Inspect the inlet strainer and if necessary, clean it with a cleaning solution suitable for the substances pumped. Refit the inlet strainer before you reconnect the pump to your vacuum system.
1. Refer to Figure 8. Disconnect your vacuum system from the pump inlet-port (3) and remove the centring-ring and strainer assembly (1) and the 'O' ring (2). Inspect the centring-ring and the 'O' ring. If they are clean, continue at Step 5. If they are not clean, continue at Step 2.
 2. Remove the 'O' ring (2) from the centring-ring and strainer assembly (1). Do not allow the 'O' ring to come into contact with the cleaning solution.
 3. Wash the centring-ring and strainer assembly in a suitable cleaning solution and allow it to dry.
 4. If necessary, wipe the 'O' ring with a clean, dry, lint-free cloth.
 5. Refit the centring-ring and strainer assembly and the 'O' ring to the inlet-port. Refit your vacuum system to the pump inlet-port.

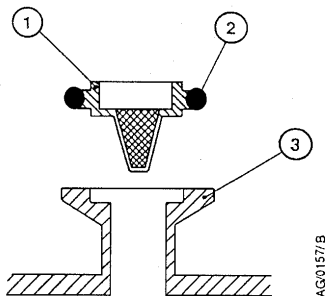

1. Centering ring and strainer
2. 'O' ring
3. Pump inlet-port

Figure 8 - Inlet strainer assembly

5.4 Inspect and clean the gas-ballast control

The gas-ballast filter element is retained in its seating with adhesive; do not try to remove it.

1. Refer to Figure 9. Turn the gas ballast control to the high flow position (II).
2. Push the control down against the compression spring as far as it will go, then turn the control anti-clockwise slightly to release the bayonet lugs and remove the control.
3. If necessary, wipe the control with a clean, dry, lint-free cloth and ensure that the air-hole is not blocked.
4. Refit the control into the gas-ballast inlet and ensure that the compression spring locates correctly between the bayonet lugs.
5. Push the control down as far as it will go and then turn the control clockwise slightly until the bayonet lugs engage correctly.
6. Reset the gas-ballast control to the required position.

5.5 Clean the external fan cover

If the fan cover and pump body are not kept clean, the air flow over the pump can be restricted and the pump may overheat.

1. Switch off the pump and disconnect it from the electrical supply.
2. Use a dry cloth and a soft brush to remove dirt and deposits from the fan cover and pump body.

5.6 Replace the tip seals

Refer to Instruction Manual A726-01-840 for instructions on how to replace the tip seals.

XDS Dry Pump

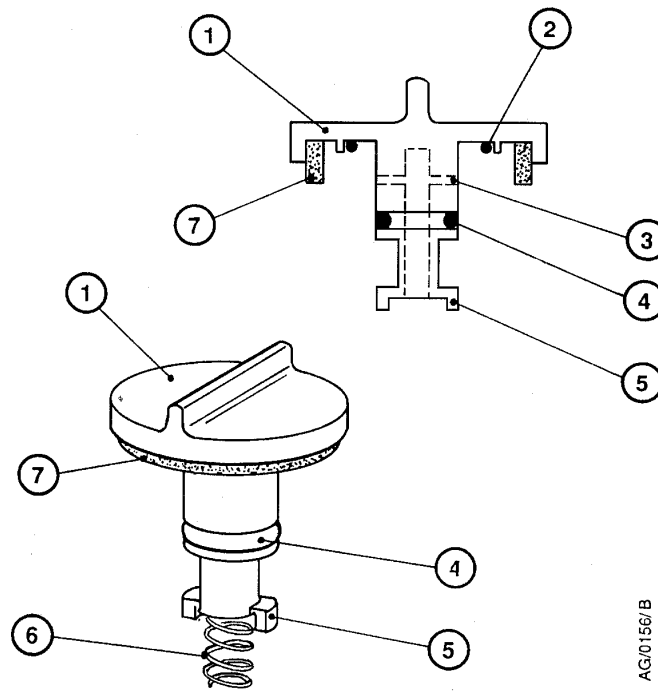

AG0156/B

- | | |
|------------------------|-----------------------|
| 1. Gas-ballast control | 5. Bayonet-lugs |
| 2. 'O' ring | 6. Compression spring |
| 3. Air-hole | 7. Filter element |
| 4. 'O' ring | |

Figure 9 - Gas-ballast control assembly

5.7 Test the motor condition

Test the earth continuity and the insulation resistance of the pump motor, in accordance with local regulations for the periodic testing of electrical equipment.

The motors of the single-phase XDS pumps comply with EN61010. We recommend that, to maintain compliance with EN61010, the earth continuity is less than 0.1 Ω and the insulation resistance is greater than 10 MΩ.

If the motor fails these tests, you must contact your supplier or BOC Edwards.

5.8 Fault-finding

5.8.1 The pump has failed to start

- The pump is not connected to the electrical supply (e.g. blown fuse, etc.).
- The electrical supply voltage does not match that for which the motor has been configured
- The motor is faulty
- Thermal overload has tripped the pump.

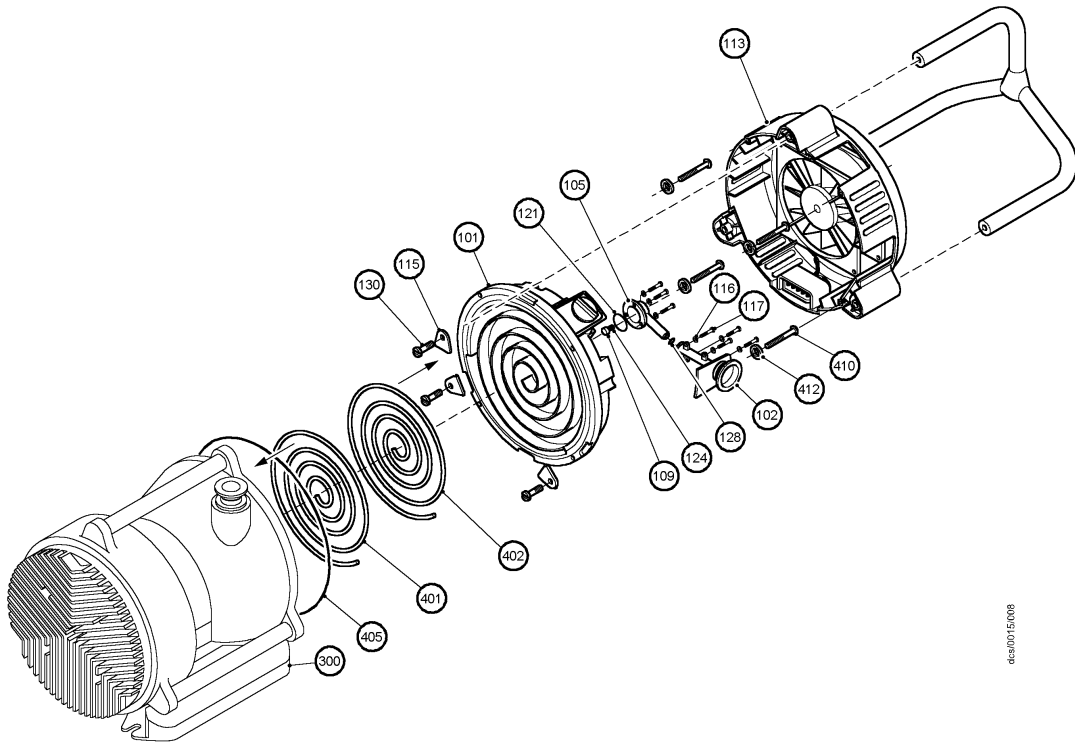

Figure 10 - Replacing the tip seals

5.8.2 The pump has failed to achieve the required performance

- There is a leak in your vacuum system
- Your pressure measurement technique or gauge head is unsuitable or gives an incorrect indication of pressure
- Your vacuum fittings are dirty or damaged
- The inlet strainer is blocked
- There is a blockage in the exhaust line
- The pump contains traces of process vapours
- The pump is outside the specified range of operating conditions
- The gas-ballast control is not properly closed
- The tip seals need replacing.

- If the electrical supply voltage is more than 10% below the lowest voltage specified on the voltage indicator, the pump may operate yielding a degraded vacuum performance.

5.8.3 The pump is noisy

- The bearings are worn
- The pump is contaminated with solid particles

5.8.4 The pump surface temperature is above 100 °C

- The ambient temperature is too high
- The cooling air supply is insufficient or is too hot
- The electrical supply voltage is too high
- The process gas is too hot.
- The fan is not working.

5.8.5 The pumping speed is poor

- The connecting pipelines are too small in diameter
- The connecting pipelines are too long
- The inlet strainer is blocked
- There is a blockage in the exhaust line.

This page intentionally blank.

6 STORAGE AND DISPOSAL

6.1 Storage

Use the following procedure to store the pump:

1. Shut down the pump as described in Section 4.
2. Disconnect the pump from the electrical supply.
3. Purge your vacuum system and the pump with dry nitrogen and disconnect the pump from your vacuum system.
4. Place and secure protective covers over the inlet and outlet ports.
5. Store the pump in cool, dry conditions until required for use. When required, prepare and install the pump as described in Section 3.

6.2 Disposal

Dispose of the pump and any components from it safely in accordance with all local and national safety and environmental requirements.

Particular care must be taken with components which have been contaminated with dangerous process substances.

Do not incinerate fluoroelastomer seals and 'O' rings.

This page intentionally blank.

7 SPARES AND ACCESSORIES

7.1 Introduction

BOC Edwards products, spares & accessories are available from BOC Edwards companies in Belgium, Brazil, Canada, France, Germany, Hong Kong, Italy, Japan, Korea, Switzerland, UK, USA and a worldwide network of distributors. The majority of these centres employ Service Engineers who have undergone comprehensive BOC Edwards training courses.

Order spare parts and accessories from your nearest BOC Edwards company or distributor. When you order, state for each part required:

- Model and item number of your equipment
- Serial number
- Item number and description of part.

7.2 Spares

Product	Item number
Tip seal kit XDS 5/10	A726-01-824

7.3 Accessories

7.3.1 Solenoid operated pipeline valve

Fit the pipeline valve between your vacuum system (refer to Table 9) and the pump inlet to provide additional system protection when the pump is switched off.

Product	Electrical Supply	Item Number	
		Aluminium	Steel
PV25EK Valve	220-240 V 50/60 Hz	C413-01-000	C413-02-000
PV25EK Valve	110-127 V 50/60 Hz	C413-03-000	C413-04-000

Table 9 - Solenoid operated pipeline valve

7.3.2 Gas-ballast adaptor

There are two gas-ballast adaptor kits which can be used depending on application requirements:

Gas-ballast adaptor kit (use with EB valve)	A505-02-000
Gas-ballast adaptor kit (controlled flow through orifice)	A506-26-801

7.3.3 Vibration isolators

Vibration isolators reduce vibration and noise when the pump is floor or frame mounted and help to reduce strain when the mounting area is uneven.

Vibration isolators (pack of 4)	A248-01-404
---------------------------------	-------------

Refer to Instruction Manual A248-01-880 for fitting instructions.

7.3.4 Exhaust nozzle kit

The exhaust nozzle screws into the outlet flange. Use the exhaust nozzle to connect the pump outlet to the 12 mm internal diameter plastic hose.

Exhaust nozzle kit	A505-09-000
--------------------	-------------

7.3.5 XDS silencer

The XDS silencer can be used to reduce exhaust noise during pump down and gas ballast operation.

XDS Silencer	A505-97-000
--------------	-------------

This page intentionally blank.

INDEX

A

Accessories	29
ATEX directive implications	1

C

Construction	3
CSA Product classification	4

D

Description	3
Dimensions	7
Disposal	27

E

Electrical data	8
Electrical installation	
single-phase pumps	12
three-phase pumps	14

F

Fault-finding	23
---------------------	----

G

Gas-ballast control	3, 17
---------------------------	-------

I

Inlet and outlet connections	16
Installation	11
Introduction	1

L

Leak test the system	16
Legislation and standards	8
Lifting the pump	12
Locate the pump	12

M

Maintenance	21
Maintenance plan	21
Mechanical data	8

N

Noise and vibration data	8
--------------------------------	---

O

Operating and storage conditions	5
Operation	17

P

Performance	5
Performance characteristics	5

R

Replace the tip seals	22
-----------------------------	----

S

Safety	11
Scope and definitions	1
Shut down	19
Single-phase pumps	8
Spares	29
Spares and accessories	29
Start up procedure	17
Storage	27
Storage and disposal	27
System design considerations	11

T

Technical data	5
Test the motor condition	23
The single-phase XDS dry pump	2
Three-phase pumps	8
To achieve ultimate vacuum	17
To pump condensable vapours	17

U

Unpack and inspect	11
--------------------------	----

This page intentionally blank.