



P-FG

LIQUID FILTER HOUSINGS

Process Filtration

Stainless steel liquid filtration housings.

Donaldson® P-FG filter housings are designed for filtration of liquids such as process water, mineral water, beer, wine, soft drinks, juice and other liquids.

Donaldson's standard P-FG is built using 304 stainless steel. It is mill finished inside with a two-part paint exterior. The housing is equipped with two pressure gauges and either FNPT or Flanged connections, depending on the housing size. The housing is equipped with a vent and clean and dirty drain ports. Our broad selection of filter elements will meet the requirements of your process.

P-FG filter housings are also available in 316 stainless steel as well as with ASME. Our seven standard sizes offer a wide range of capacity depending on element selection. Custom housings are available upon request.



P-FG

SPECIFICATIONS

MATERIALS

Housing Material	304L SS (316L SS available upon request)
Gasket Material	EPDM (other materials available upon request)

CONNECTION TYPES

0050-0250	FNPT
0450-1000	ANSI/ASME Flange, Class 150

DESIGN PRESSURE AND TEMPERATURE

10.4 bar @ 149° C (150 psig @ 300° F) with EPDM gaskets

SURFACE FINISH

Inner	Mill finish stainless steel
Outer	Bead blast

MAXIMUM INLET TEMPERATURE

Up to 149° C (300° F)

DIMENSIONS

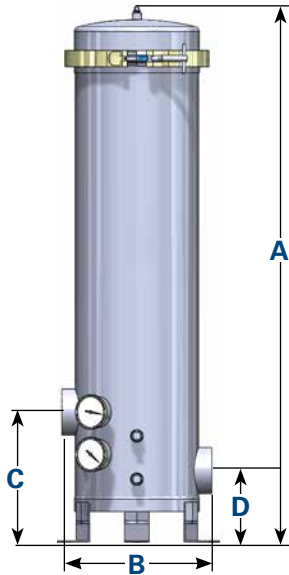

P-FG 0050-0250

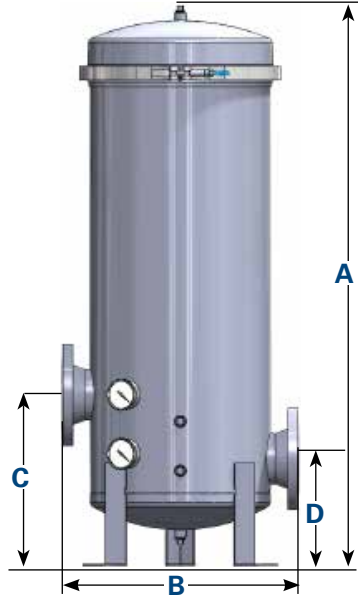

P-FG 0450

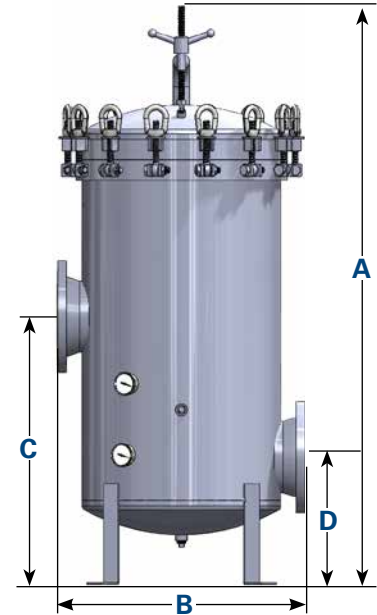

P-FG 0700 and 1000

Model Number	Closure	Capacity		Connection	Dimensions								Weight w/o Element		Element (DOE)		Item Number		
					Height A		Width (± 0.250) B		Connection Height		Clearance								
					mm	in.	mm	in.	Inlet C	Outlet D		mm						in.	
P-FG 0050	Clamp	189	50	51 mm (2") FNPT	841	33.1	251	9.9	241	9.5	140	5.5	584	23	15.0	33	20/30	4	1C105212
P-FG 0100	Clamp	379	100	51 mm (2") FNPT	1095	43.1	251	9.9	241	9.5	140	5.5	838	33	18.6	41	30/30	5	1C105213
P-FG 0150	Clamp	568	150	76 mm (3") FNPT	1090	42.9	312	12.3	269	10.6	147	5.8	838	33	29.5	65	30/30	7	1C105214
P-FG 0250	Clamp	946	250	76 mm (3") FNPT	1260	49.6	363	14.3	391	15.4	254	10.0	838	33	41.7	92	30/30	12	1C105215
P-FG 0450	Clamp	1703	450	102 mm (4") ANSI Flange	1250	49.2	533	21.0	389	15.3	244	9.6	838	33	66.2	146	30/30	22	1C105216
P-FG 0700	Swing Bolt Only	2650	700	152 mm (6") ANSI Flange	1750	68.9	655	25.8	823	32.4	356	14.0	838	33	152.4	336	30/30	36	1C105217
P-FG 1000	Swing Bolt Only	3785	1000	203 mm (8") ANSI Flange	1778	70.0	762	30.0	823	32.4	391	15.4	838	33	263.5	581	30/30	52	1C105218



Important Notice

Many factors beyond the control of Donaldson can affect the use and performance of Donaldson products in a particular application, including the conditions under which the product is used. Since these factors are uniquely within the user's knowledge and control, it is essential the user evaluate the products to determine whether the product is fit for the particular purpose and suitable for the user's application. All products, specifications, availability and data are subject to change without notice, and may vary by region or country.



Donaldson Company, Inc.
Minneapolis, MN

donaldson.com
shop.donaldson.com

Australasia 61-02-4350-2066
marketing.australia@donaldson.com

Brazil 55-11-4894-6035
vendas.brasil@donaldson.com

China 86-400-921-7032
info.cn@donaldson.com

EMEA 49-2129-569-0
cap-europe@donaldson.com

India 91-124-4807-400
indiaquiries@donaldson.com

Japan 81-42-540-4123
ndl-ultrafilter-web@donaldson.com

Korea 82-2-517-3333
cap-kr@donaldson.com

Latin America 52-449-300-2442
industrialair@donaldson.com

North America 800-543-3634
processfilters@donaldson.com

South Africa 27-11-997-6000
samarketing@donaldson.com

Southeast Asia 65-6311-7373
sea.salesenquiry@donaldson.com