

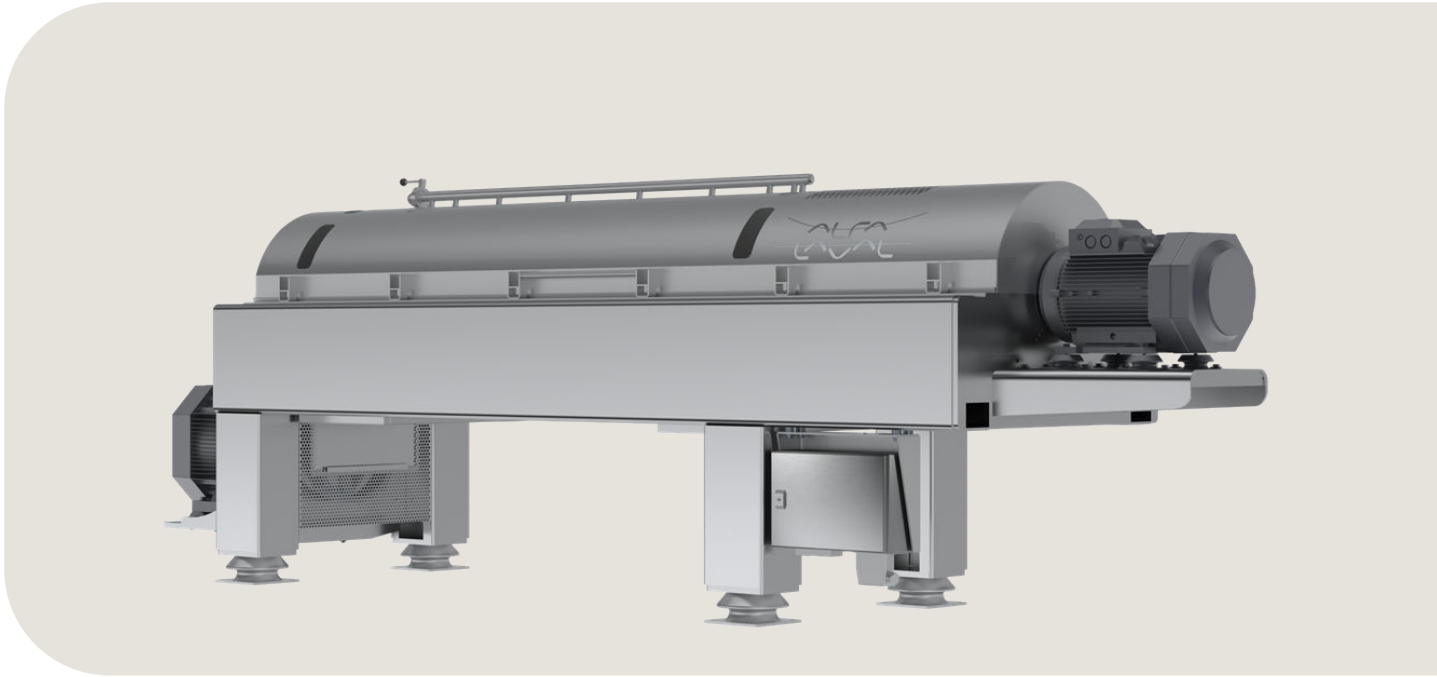

The Alfa Laval Foodec range of decanter centrifuges

High-performance separation in food processing operations



Applications

Alfa Laval Foodec decanter centrifuges are specially designed for use in food processing applications where hygiene standards are particularly important in order to comply with strict sanitary regulations.

Foodec decanters are ideal for use in food industry applications in which the material being processed has to be separated into a liquid and a solid phase. Foodec units are available with two-phase gravity liquid discharge or with pressurized liquid discharge (paring disc) Foodec decanters deliver a high extraction yield and a very low solids content in the liquid.

For uses where levels of cleanability has a higher demand, special Foodec Hygiene Plus units are available, with additional features that make cleaning easier, faster and even more straightforward.

Benefits

Foodec decanter centrifuges feature a consistent focus on reliability, cleanability, continuous operation and easy maintenance. High-quality stainless steel is used throughout the decanter and the frame is also available in stainless

steel (as an option). The cover is designed to ensure easy access and is hinged for easy opening, maintenance and cleaning, thanks to the spring assisted opening system.

The rotating assembly is mounted on a compact welded box beam frame, with bearings at both ends. The drive system comprises a planetary gearbox, driven by a variable frequency drive. Direct Drive is used as the basis for a unique system that automatically controls the differences between how fast the bowl and the conveyor rotate. The electrical installation is straightforward, power consumption is very low and accurate control is achieved within a wide range of differential speeds, with no need to change belts and pulleys. This all makes it easy to maintain the best possible balance between clarification and recovery at any given instant, regardless of variations in the feed.

One of the most important features of the Alfa Laval Foodec range lies in the opportunity to implement full cleaning-in-place (CIP) procedures. These are supported by a specially designed CIP feed tube and an optional CIP bar is mounted on the decanter cover to provide the best cleaning effect. Foodec decanter centrifuges are always fitted with food-approved elastomers and seals.

Working principles

The Foodec decanter centrifuge design makes sure the incoming product is effectively separated into liquid and wet solids.

Separation takes place over the entire length of the cylindrical part of the bowl, which is equipped with a concentric screw conveyor. The product is fed into the bowl through a stationary inlet tube and is smoothly accelerated by the feed zone in the conveyor. Centrifugal forces cause instant sedimentation of the solids on the wall of the bowl. The clarified liquid leaves the bowl by flowing naturally under

gravity, over an adjustable weir (dam plate) and into the casing. Pressurized liquid discharge (using a paring disc) is also available, making it possible to transfer the liquid directly without any ambient contact.

The conveyor rotates in the same direction inside the bowl but at a slightly different speed. This difference between bowl and conveyor can be adjusted either manually or automatically. This difference in speed moves the solids to the conical end, where they are lifted out of the liquid. The solids are drained before being discharged out of the machine through the solids outlet.

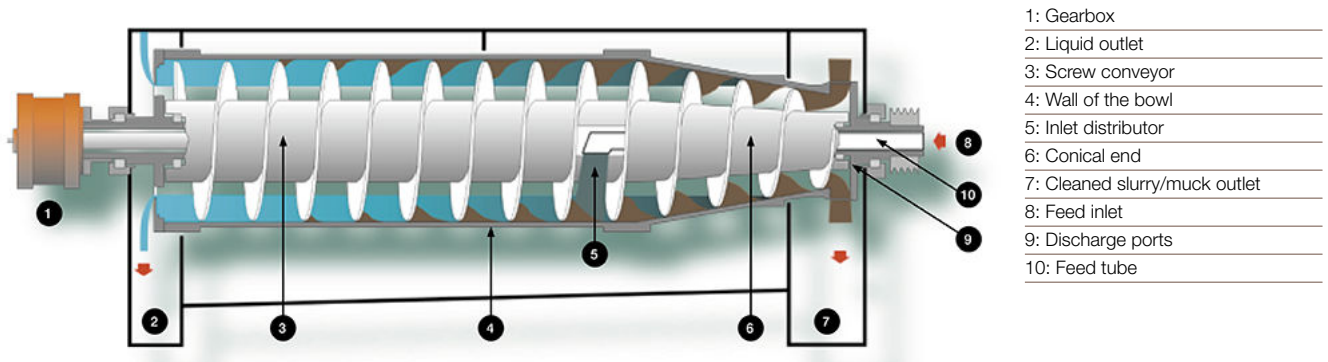

Process optimization

Foodec decanter centrifuge operations can be adjusted to suit your individual requirements by varying:

- Bowl speed, to ensure the exact G-force required for optimal separation
- Conveyor speed, for the required balance between liquid clarity and solids discharge
- Pond depth in the bowl, which can be adjusted to achieve the desired balance between liquid clarity, solids dryness and an inter-phase setting between heavy and light liquid phase
- Feed flow rate – can deal with a wide range of different flow rates.

Automation

Decanter centrifuges in the Foodec decanter range are equipped with variable frequency drives (VFD) and are also available with control solutions to comply with your specific operating requirements.

Connectivity

Foodec decanter centrifuges can also be fitted with other additional connectivity equipment that provides you with a wide range of operating data, whether on-site or remote. Please refer to the Alfa Laval website for more information.



Cleaning feature – CIP bar

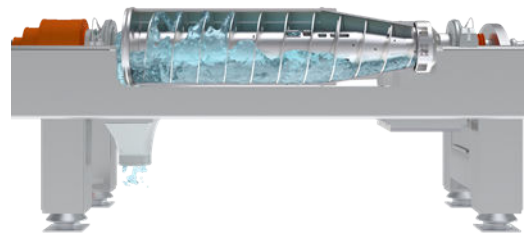

CIP cleaning effects

Optional features

Alfa Laval Foodec decanter centrifuges are available with other options based on your specific operating requirements. For applications where low energy consumption is important, energy-saving power tubes can reduce the overall energy footprint. If oxidation or foaming are a concern, Foodec units are available in a paring disc configuration, featuring a pressurized outlet.

If higher levels of hygiene are required, the Foodec Hygiene Plus model contains all the most advanced features for outstanding drainability and cleanability on the inside as well as the outside of the centrifuge bowl, including smooth surfaces, to help maintain optimal hygiene. Foodec Hygiene Plus units are also available with additional TrueStainless and SaniRibs options:



SaniRibs®

The cleaner, more efficient way to transport solids.

Our unique seal welded ribs create more friction which offers better, more efficient solids transportation. This innovative technology also eliminates pathogen hot-spots and allows for easy cleaning, meaning longer production runs, less manual maintenance, and improved profits.



TrueStainless™

Designed for long lasting and unparalleled hygiene.

TrueStainless ensures that solid stainless steel is used for all decanter parts which are in contact with a corrosive atmosphere, securing long-lasting, maximal uptime and superior hygiene.

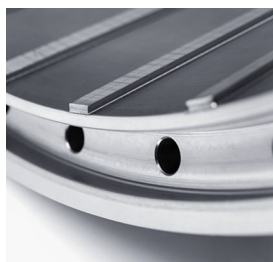

SaniRibs® - Hygienic solids transportation

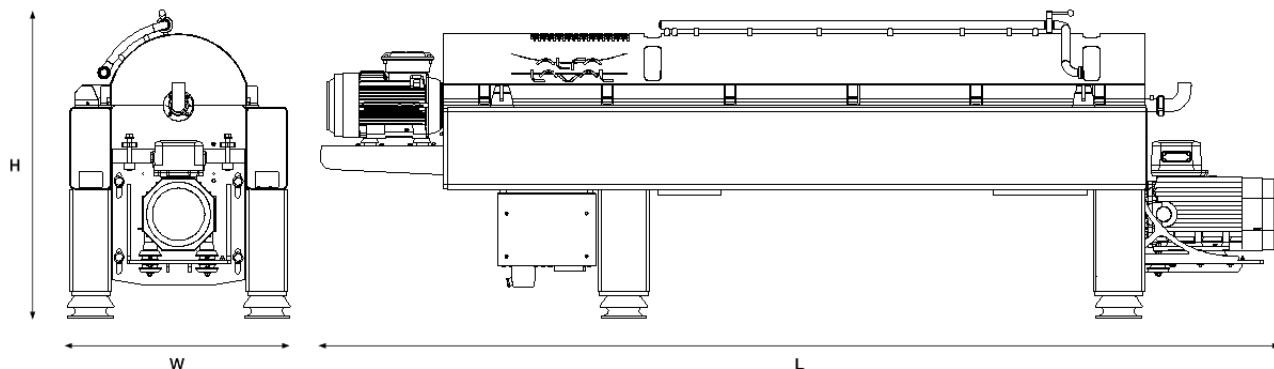

Technical data

Designation	Foodec 100	Foodec 209	Foodec 300T	Foodec 400T
Bowl diameter	200 mm / 7.9 inches	280 mm / 11 inches	360 mm / 14.2 inches	440 mm / 17.3 inches
Bowl speed (Maximum)	5300 rpm	4400 rpm	4200 rpm	3800 rpm
G-force (Maximum)	3140 G	3030 G	3549 G	3551 G
Gross weight	375 kg / 830 lbs	1200 kg / 2660 lbs	2300kg / 5071 lbs	3200 kg / 7050 lbs
Length (L)	2150 mm / 85 inches	3216 mm / 127 inches	3998 mm / 168 inches	4749 mm / 195 inches
Width (W)	580 mm / 23 inches	780 mm / 31 inches	990 mm / 39 inches	1060 mm / 42 inches
Height (H)	762 mm / 30 inches	930 mm / 37 inches	1304 mm / 51 inches	1376 mm / 54 inches

Designation	Foodec 505T	Foodec 600T	Foodec 700	Foodec 800T
Bowl diameter	500 mm / 19.7 inches	550 mm / 21.7 inches	650 mm / 25.6 inches	720 mm / 28.3 inches
Bowl speed (Maximum)	3600 rpm	3400 rpm	3100 rpm	2900 rpm
G-force (Maximum)	3622 G	3554 G	3491 G	3384 G
Gross weight	4900 kg / 10,800 lbs	5000 kg / 11,023 lbs	6500 kg / 14,300 lbs	8600 kg / 18,959 lbs
Length (L)	5076 mm / 200 inches	5842 mm / 230 inches	6502 mm / 256 inches	6901 mm / 264 inches
Width (W)	1190 mm / 47 inches	1300 mm / 51 inches	1450 mm / 57 inches	1510 mm / 60 inches
Height (H)	1534 mm / 61 inches	1696 mm / 67 inches	1791 mm / 71 inches	1852 mm / 73 inches

This document and its contents are subject to copyrights and other intellectual property rights owned by Alfa Laval Corporate AB. No part of this document may be copied, re-produced or transmitted in any form or by any means, or for any purpose, without Alfa Laval Corporate AB's prior express written permission. Information and services provided in this document are made as a benefit and service to the user, and no representations or warranties are made about the accuracy or suitability of this information and these services for any purpose. All rights are reserved.

How to contact Alfa Laval

Up-to-date Alfa Laval contact details for all countries are always available on our website at www.alfalaval.com