

Productivity and Reduced Footprint for Industrialization of Animal Cell Culture Processes in a Fixed-Bed Bioreactor

The iCELLis bioreactor system is an automated, single-use, fixed-bed bioreactor, that provides excellent cell growth conditions for adherent cells.

The bioreactors system main features include:

- Cell culture process simplification, from vial to product
- Fully-integrated, single-use iCELLis 500+ bioreactor with disposable, pre-installed calibrated probes
- Unique waterfall system for optimal oxygenation and CO₂ stripping
- Compact high-cell-density, fixed-bed bioreactor providing a significant increase in volumetric productivity vs. traditional stirred tanks
- Predictable scalability from R&D to manufacturing
- Significant decrease in operational costs and capital investments vs. classical 2D flatware

Central to the iCELLis bioreactor technology is the use of a compact fixed-bed, filled with proprietary macrocarriers. This matrix is made of class VI(1) polyester microfibers and provides a surface area for cell growth up to 500 m². This is the surface equivalent of 3,000 roller bottles (Figure 1). The iCELLis bioreactor comes pre-packed with macrocarriers.

Because of the cell to cell interactions within the 3D environment of the fixed-bed, iCELLis bioreactors can be inoculated at very low density, 3,000 cells per cm² and even lower points. The seed train can as such be streamlined and simplified, leading to less manual operations and a reduction of associated costs.

Evenly-distributed media circulation is achieved by a built-in magnetic drive impeller, ensuring low shear stress and high cell viability (Figure 2). The cell culture medium flows through the fixed-bed from the bottom to the top. At the top, the medium falls as a thin film down the outer wall where it takes up O₂ to maintain high k_La in the bioreactor. This unique waterfall oxygenation, together with a gentle agitation and biomass immobilization, enables the compact iCELLis bioreactor system to achieve and maintain high cell densities – equaling the productivity of much larger stirred-tank units.



Process simplification, from vial thawing to final product, is at the heart of the iCELLis bioreactor platform. Cells are immobilized in the fixed-bed, acting as a natural cell retention device when the bioreactor is operated in perfusion or recirculation mode. The fixed-bed also acts as a clarifying filter during product harvest, so no centrifugation is required. This benefit further simplifies the downstream process.

Figure 1

The iCELLis 500+ bioreactor (500 m²) is equivalent to 3,000 roller bottles (1700 cm² each)

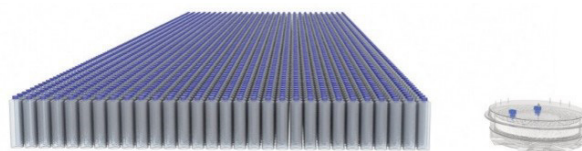

Figure 2

Media flow in the iCELLis 500+ bioreactor (60 - 70 L)

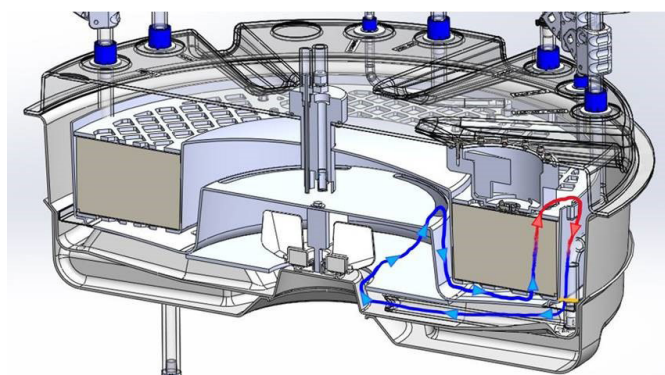

Figure 3

Microscopy view of MDCK cells immobilized on iCELLis system carriers

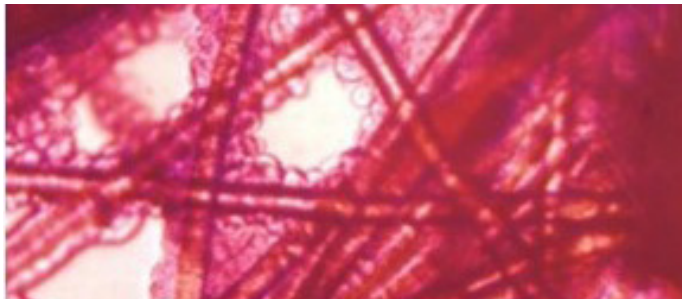

Table 1

Configurations of iCELLis bioreactors at small and manufacturing scale

Bioreactor	Bioreactor Diameter (mm)	Fixed-Bed Height (mm)	Fixed-Bed Volume (L)	Bioreactor Volume (L)	Surface Area (m ²)	
					Low Compaction	High Compaction
iCELLis Nano	110	20	0.04	1	0.53	0.8
iCELLis Nano	110	40	0.08	1	1.06	1.6
iCELLis Nano	110	100	0.2	1	2.65	4
iCELLis 500+/100	860	20	5	70	66	100
iCELLis 500+/200	860	40	10	70	133	200
iCELLis 500+/500	860	100	25	70	333	500

Both systems have an integrated mixing system for evenly-distributed media circulation and low shear stress, waterfall media oxygenation for high oxygen transfer and use the same macrocarriers specifically adapted to adherent cell cultures. The height of fixed-bed can be varied – from 2 cm to 10 cm – offering six different configurations of small and large scale. The scaling from the small bioreactor to the large one is straightforward, and typically based on retention of compaction and fixed-bed height (Figure 4).

System Overview, Features and Benefits

The iCELLis bioreactor system is available in two formats (Table 1 and Figure 5):

- The iCELLis Nano system for feasibility studies and small-scale production (up to 4 m²)
- The iCELLis 500+ system for industrial scale manufacturing (up to 500 m²)

Figure 4

iCELLis bioreactor bench (Nano) and manufacturing (500+) scales and their modular size fixed-bed. LC = low compaction; HC = high compaction

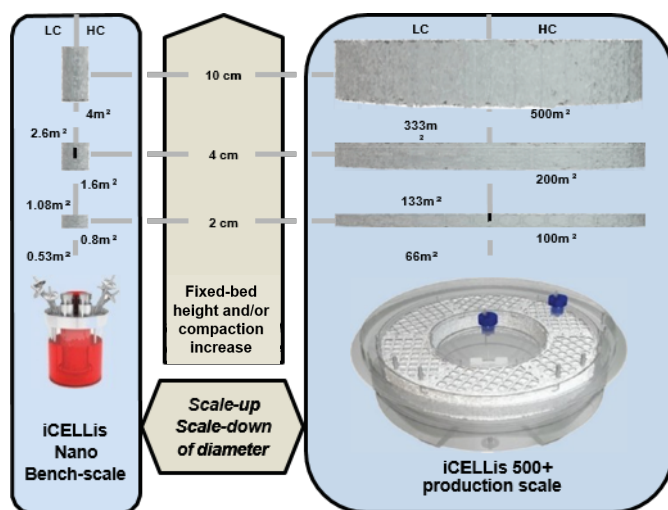

Figure 5

iCELLis Nano bioreactor (left) and iCELLis 500+ bioreactor (right)

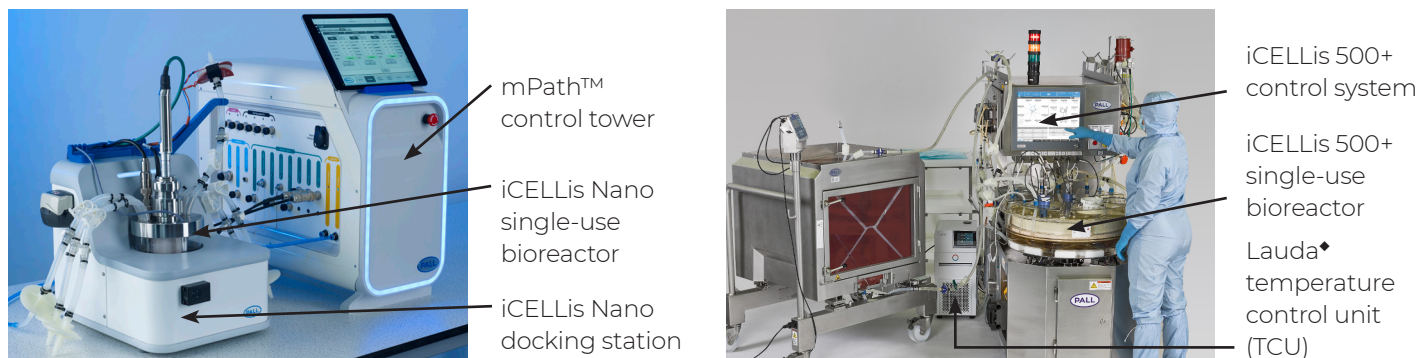

Table 2

iCELLis Nano bioreactor system

Feature	Benefit
Bioreactor with re-usable electrochemical sensors	Monitoring of dissolved oxygen (DO), pH, temperature and biomass possible
Hardware features docking station with perfusion integrated and mPath control tower and mPath link server	Ergonomic and robust industrial design, using same controller as all other Pall benchtop bioreactor systems
IP54 rated hardware	Ready for use in cleanrooms
Advanced alarming	Color coded illumination allows identification of operating state from distance
Internal bioreactor pressure measurement	Pressure monitoring prevents overfilling of the bioreactor during perfusion, reducing spills
Temperature control and advanced heating through resistors	Maintain temperature and heat from 20 to 37 °C within 1 hour
Gas handling by six oxygen-rated thermal mass flow controllers (TMFCs)	Accurate gas mixing enabling accurate parameter control
Integrated cable management tools	Ease-of-use and ergonomics
<p>Control Software – mPath Link</p> <p>The mPath control tower is designed for use with the mPath Link server and software - a supervisory control and data acquisition (SCADA) software package</p>	<p>See mPath Benchtop Bioreactor Control Towers (USD 3220) for more information</p> <p>Capable of accessing data anywhere on any networked device including laboratory workstations, desktop computers, or remote devices such as laptops, mobile phones, and tablets</p> <p>Operates as either a standalone network or integrated with site IT systems, compatible with multiple network security approaches (e.g. virtual private network [VPN]) and password protection to protect bioreactors from unauthorized access</p> <p>Intuitive visual displays for easy interaction with bioreactors to calibrate components, set critical parameters, and fine tune process control</p> <p>Advanced trending capability including creation of custom trends of any process variable for both historic and live processes. Overlay and compare trends from multiple batches on one graph</p> <p>Database centric design supports naming, logging, and exporting batches for traceability and data analysis</p> <p>Full alarm customization to alert for process or safety critical events</p> <p>User-definable recipes including scheduling, version control and retirement for recipes no longer in use. Recipes can be multi-phased with user-defined transitions between each phase</p> <p>Compliance capability – designed for operation following 21 CFR Part 11/Annex 11 regulations</p>

The iCELLis 500+ bioreactor is a single-use system made of material free of animal origin components and tested for Class VI USP⁽¹⁾ compliance. The bioreactor is set on a fully integrated system including docking station, perfusion pumps and controller. The iCELLis 500+ bioreactor has an integrated SCADA 21 CFR Part 11 compliant software that will control all process parameters – pH⁽²⁾, DO, gas flow, temperature, stirring speed, biomass – throughout the duration of the culture.

Table 3

iCELLis 500+ bioreactor system

Feature	Benefit
Single-use bioreactor made of USP Class VI ⁽¹⁾ materials free of animal origin components and supplied gamma-irradiated	Ease-of-use, plug and play concept, with no cleaning validation for product contact components required
Bioreactor with single-use sensors	Monitoring of DO, pH ⁽²⁾ , temperature and biomass and possible, in addition to bioreactor pressure
Equipped with Kleenpak® Presto sterile connectors	Allows for the sterile connection of two fluid paths
Hardware features docking station with perfusion integrated and controller	Ergonomic and robust industrial design
Overflow control and internal bioreactor pressure measurement	Prevents spill
Temperature control and heating through temperature control unit and integrated double jacket	Robust temperature control
Integrated tubing management tools	Ease-of-use and ergonomics
Process control	<ul style="list-style-type: none"> – Designed in accordance to good automated manufacturing practice (GAMP) and for operation following 21 CFR Part 11/Annex 11 regulation – Recipe manager plus to create recipes, controlling automatically the system and generating batch reports for audits – SCADA system based on Wonderware® ArchestrA which offers maximum functionality for process control and data acquisition and recipe management – The data and alarms generated during the cell culture batch are stored on a local SSD drive in a secured database – An ethernet port is included in the system to connect it to the user's network and enable custom data history

Performance and Applications

The fixed-bed design of the iCELLis system makes it the perfect solution for industrialization of adherent cell processes and virus production for both gene therapy and vaccines, providing a large cell growth surface area while keeping the footprint very small. The iCELLis system accommodates up to 500 m² of growth area, which, when compared with available surfaces of multitray systems and roller bottles, corresponds to a huge reduction in volumes. Table 4 illustrates the iCELLis 500+/500 m² system is equivalent to 794 cell stacks with 10 trays and 5,882 roller bottles at 850 cm² each.

Table 4

Available largest surface area in the iCELLis Nano and iCELLis 500+ systems and comparison with multitray cell factory systems (CF) / roller bottles (RB)

	Fixed-Bed Volume (L)	Equivalent Culture Surface (m ²)	Equivalent CF10 (6,300 cm ²)	Equivalent Roller Bottles (850 cm ²)
iCELLis Nano fixed-bed height 10 cm	0.2	4	6	47
iCELLis 500+/500 m ² fixed-bed height 10 cm	25	500	794	5,882

In addition to volume reduction, the use of a filled, fixed-bed in the iCELLis system enables higher specific productivity than in other culture systems. Table 5 below shows data on yield achieved for most common vectors. Results clearly highlight that the growth matrix inside the iCELLis system is a favored growth environment which, together with controlled cell culture parameters, can significantly increase the biomass amplification, as well as the number of viral particles produced by each cell (specific productivity). Additional experiments demonstrated that iCELLis bioreactors require limited adaptation protocols and enable easy, straightforward scale-up for the majority of mammalian cell lines.

(1) As per standards USP <87> biological reactivity test, *In Vitro*, cytotoxicity; USP <88> biological reactivity tests *In Vivo*, for Class VI - 50 °C plastics; and USP <661> containers - plastic.

(2) The correct level of accuracy can only be expected at the pH value at which the 1-point calibration is performed. The greater the distance from the point of calibration, the lower the probability that the accuracy will be within specification. Therefore, if these bioreactors demonstrate a greater distance, then Pall's recommendation is that the bioreactors can only be used under mitigation actions, specifically manual pH control. Pall's dedicated application team can provide support for these mitigation actions.

Table 5

Specific productivities achieved with iCELLis systems with several kinds of vectors produced from different mammalian cell lines

Vector	Cell	Size	Yield/cm ²	Unit	Yield Extrapolated to 500 m ²	Source
Adeno-Associated Virus (AAV)	HEK293T	0.53 m ²	2.15 x 10 ¹⁰	VG	1.08 x 10 ¹⁷	University of Ulm (2015 article) ¹
	HEK293T/17	0.53 m ²	9.06 X 10 ¹⁰	VG	4.53 x 10 ¹⁷	St. Jude (2016 article) ²
	HEK293	333 m ²	3.00 x 10 ⁹	VG	>1.00 x 10 ¹⁶	Avexis♦ (2019 poster) ³
Lentiviral	HEK293T	133 m ²	4.14 x 10 ⁷	pfu	2.07 x 10 ¹⁴	MolMed♦ (2020 conference presentation) ³
		2.7 m ²	1.05 x 10 ⁶	TU	5.25 x 10 ¹²	St. Jude (2020 article) ⁴
Retroviral	AM12	1.06 m ²	9.9 x 10 ⁵ (stable)	TU	4.95 x 10 ¹²	MolMed♦ (2018 conference presentation) ³
	HEK293 Vec	2.7 m ²	9.38 x 10 ⁷ (stable)	TU	4.69 x 10 ¹⁴	Memorial Sloan Kettering Cancer Center♦ (2015 article) ⁵
Adenoviral	HEK293	100 m ²	6.10 x 10 ⁹	VP	3.05 x 10 ¹⁶	FinVector (2015 article) ⁶
		66 m ²	1.57 x 10 ¹⁰	VP	7.85 x 10 ¹⁶	Orgenesis♦ (2017 poster) ³

Documentation and Certificates

The iCELLis bioreactors are delivered with complete documentation that qualifies the system. All units are tested prior to shipment and witnessed factory acceptance testing (FAT) is available on request. The biocontainer bags are delivered with all the batch specific certificates and calibration information for the included single-use sensors. Pall also can assist with hardware qualification, and standard installation verification (IV), operational verification (OV), and site acceptance test (SAT) test protocols are available.

Preventive Maintenance and Service Packages

The iCELLis systems are supported with extensive maintenance and service packages. Pall has a global network of technicians and engineers available to assist with installation, qualification, training, technical support, preventive maintenance and on-site repairs. Contact Pall to discuss any of these services. Pall's AcceleratorSM process development services provide customers with expert advice and support for the implementation of fully integrated single-use processing solutions into new or existing processes, including process optimization, equipment selection, transfer of existing processes, scale-up and troubleshooting advice. Details can be found in the Accelerator process development services brochure (USD 3333). Preventive maintenance packages are available to ensure the continuous reliable operation of the iCELLis bioreactor and to minimize downtime. Preventive maintenance typically includes a full functional test, exchange of wear parts, and calibration of all sensors. Details can be found in our service plans brochures (USD 3390 for the iCELLis Nano bioreactor and USD 3391 for the iCELLis 500+ bioreactor).

General System Specifications

	iCELLis Nano System	iCELLis 500+ System
Dimensions (W x D x H) (mm)		
Controller	230 x 600 x 450	1038 x 1609 x 2122
Docking station	340 x 360 x 290	
Weight (kg)		
Controller	20 kg	650 kg (without TCU)
Docking station	6.7 kg	
Gases connections	Quick connectors 6 mm	Male swagelock ¼ in. connector
Control	TMFC	TMFC
O ₂	0 - 1000 mL/min	0 - 7000 mL/min
CO ₂	0 - 1000 mL/min	0 - 1500 mL/min
N ₂	0 - 1000 mL/min	0 - 1500 mL/min
Air	0 - 1000 mL/min	0 - 3000 mL/min
Pumps	1 x fixed speed (base addition); 2 x variable speed (perfusion in-out)	5 x (perfusion in-out, base addition, sampling and inoculation), (7 if optional fill and drain pumps are ordered)
Agitation control and range	Magnetic drive impeller (100 - 1500 rpm)	Magnetic drive impeller (0 - 450 rpm)
Temperature control and range	Resistors – Peltier elements 20 - 40 °C	Double jacket – TCU 25 - 40 °C
pH⁽²⁾ control	Electrochemical, re-use 0 - 14	Single-use, optical 3 - 10 ⁽²⁾
DO control	Electrochemical, re-use 0 - 150% air saturation	Single-use, optical 0 - 300% air saturation
Control architecture	PLC	PLC
SCADA	mPath Link software – any device connected	Wonderware

Ordering Information

iCELLis Nano Hardware

Description	Part Number
iCELLis Nano bioreactor system	ICLNANOBR5
mPath Link server and SCADA software	MPATHLINKV2

iCELLis Nano Single-Use Bioreactors

Part Number	Part Number (Biomass Compatible)	Surface Area for Cell Growth (m ²)
810039NS	4415-40-LC-BM	0.53
810040NS	4415-40-HC-BM	0.80
810061NS	4415-80-LC-BM	1.06
810041NS	4415-80-HC-BM	1.60
810206NS	4415-200-LC-BM	2.65
810042NS	4415-200HC-BM	4.00

iCELLis Nano Single-Use Manifolds

Part Number	Description
6415-1384T	Base manifold (gamma irradiated)
6415-1384U	Sampling manifold 1 L (gamma irradiated - manifold for sampling, feeding, harvesting)
6415-1384W	Lid tubing (non-sterile - 6 tubing assemblies with CPC and vent filter for bioreactor head plate)
6415-1384S	Recirculation loop manifold 2 L (gamma irradiated)
6415-1540F	Recirculation loop manifold 5 L (gamma irradiated)
6415-1540G	Recirculation loop manifold 10 L (gamma irradiated)

iCELLis 500+ Hardware

Part Number	Description
ICL500CSSPH	iCELLis 500+ process control system (universal)
ICL500HFLPUMP	iCELLis 500+ high flow pumps (optional)
ICL500LTCU120	iCELLis 500+ Lauda TCU 120 V
ICL500LTCU230	iCELLis 500+ Lauda TCU 230 V

iCELLis 500+ Single-Use (SU) Bioreactors 10 cm Falling Film

Part Number	Description
4415-R66	iCELLis 500+ SU vessel 66 m ² with Kleenpak sterile connectors
4415-R133	iCELLis 500+ SU vessel 133 m ² with Kleenpak sterile connectors
4415-R333	iCELLis 500+ SU vessel 333 m ² with Kleenpak sterile connectors
4415-R100	iCELLis 500+ SU vessel 100 m ² with Kleenpak sterile connectors
4415-R200	iCELLis 500+ SU vessel 200 m ² with Kleenpak sterile connectors
4415-R500	iCELLis 500+ SU vessel 500 m ² with Kleenpak sterile connectors
4415-R66BM	iCELLis 500+ SU vessel 66 m ² with Kleenpak sterile connectors and biomass probe
4415-R133BM	iCELLis 500+ SU vessel 133 m ² with Kleenpak sterile connectors and biomass probe
4415-R333BM	iCELLis 500+ SU vessel 333 m ² with Kleenpak sterile connectors and biomass probe
4415-R100BM	iCELLis 500+ SU vessel 100 m ² with Kleenpak sterile connectors and biomass probe
4415-R200BM	iCELLis 500+ SU vessel 200 m ² with Kleenpak sterile connectors and biomass probe
4415-R500BM	iCELLis 500+ SU vessel 500 m ² with Kleenpak sterile connectors and biomass probe
4415-R66SP	iCELLis 500+ SU vessel 66 m ² with Kleenpak sterile connectors and non aseptic sampling port

All iCELLis 500+ single-use bioreactors exist in 6 cm falling film version – contact your Pall representative for references

iCELLis 500+ Single-Use Manifolds

Part Number	Description
6415-I500MFLA	iCELLis 500+ starter kit low flow Allegro® film

Contains		Qty
6415-0615S	iCELLis 500+ manifold inoculum 2 L and 10 L biocontainer	1
6415-0615T	iCELLis 500+ manifold base addition	1
26415-0464F	iCELLis 500+ manifold feed in 2 low flow	1
16415-0464G	iCELLis 500+ manifold harvest and feed out low flow	1
6415-0615V	iCELLis 500+ manifold feed in 1 for heating module low flow	1
6415-0615U	iCELLis 500+ manifold sampling with Kleenpak sterile disconnecter	1

Part Number	Description
6415-I500MFHA	iCELLis 500+ starter kit high flow Allegro film

iCELLis 500+ Starter Kit Low Flow Allegro Film Contains		Qty
6415-0458Z	iCELLis 500+ manifold harvest and feed out high flow	1
6415-0615S	iCELLis 500+ manifold inoculum 2 L and 10 L biocontainer	1
6415-0615T	iCELLis 500+ manifold base addition	1
6415-0464C	iCELLis 500+ manifold feed in 2 high flow	1
6415-0615R	iCELLis 500+ manifold feed in 1 for heating module high flow	1
6415-0615U	iCELLis 500+ manifold sampling with Kleenpak sterile disconnecter	1

Figure 6

iCELLis Nano bioreactor and mPath control tower



The iCELLis bioreactors are available as standard models and both the bioreactor hardware and consumables can be customized. Please contact a Pall representative to find the ideal solution for your application. Our teams are specialized in upstream and downstream processing and will gladly help find the right technology for any part of your manufacturing process. It is possible to combine products to meet any requirement in the upstream part of the process:

- Media preparation
- Buffer preparation
- Media sterilization and aseptic transfer liquid transfer into the bioreactor (e.g. glucose, anti-foam, base, etc.)
- Seed train solutions
- Cell harvest and separation

Please contact Pall for a total solution discussion on your process.

Figure 7

iCELLis 500+ bioreactor

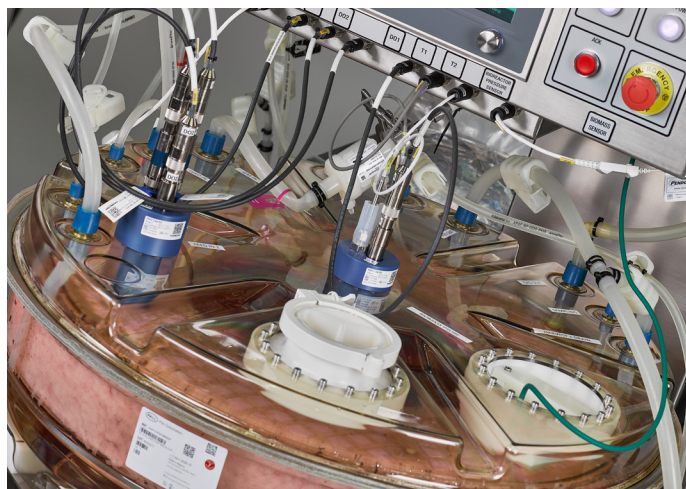

References

1. Emmerling, V.V., Pegel, A., Milian, E.G., Venereo-Sanchez, A., Kunz, M., Wegele, J., Kamen, A.A., Kochanek, S., Hoerer, M., "Rational plasmid design and bioprocess optimization to enhance recombinant adeno-associated virus (AAV) productivity in mammalian cells." *Biotechnology Journal*, 11: 290-297. (2016). <https://doi.org/10.1002/biot.201500176>
2. Powers, A., Piras, B.A., Clark, R.K., Lockey, T.D., Meagher, M.M., "Development and Optimization of AAV hFIX Particles by Transient Transfection in an iCELLis Fixed-Bed Bioreactor," *Human Gene Therapy Methods*, Jun 2016; 27(3): 112-21. <https://doi.org/10.1089/hgtb.2016.021>
3. Available upon request. Please ask your account manager or applications scientist.
4. Powers, A., Drury, J.E., Hoehamer, C.F., Lockey, T.D., Meagher, M.M., "Lentiviral vector production from a stable packaging cell line using a packed bed bioreactor," *Molecular Therapy*, 2020, Vol 19, p1-13. <https://doi.org/10.1016/j.omtm.2020.08.010>
5. Wang, X., Olszewska, M., Qu, J., Wasielewska, T., Bartido, S., Hermetet, G., Sadelain, M., Rivière, I., "Large-scale clinical-grade retroviral vector production in a fixed-bed bioreactor." *Journal Immunotherapy*. 2015; 38(3):127-135. <https://doi.org/10.1097/CJI.0000000000000072>
6. Lesch, H.P., Heikkilä, K.M., Lipponen, E.M., Valonen, P., Müller, A., Räsänen, E., Tuunanen, T., Hassinen, M.M., Parker, N., Karhinen, M., Shaw, R., Ylä-Hettuala, S., "Process development of Adenoviral vector production in fixed-bed bioreactor – from bench to commercial scale," *Human Gene Therapy*, 2015, 26(8): 560-71. <https://doi.org/10.1089/hum.2015.081>



Corporate Headquarters

Port Washington, NY, USA
+1-800-717-7255 toll free (USA)
+1-516-484-5400 phone

European Headquarters

Fribourg, Switzerland
+41 (0)26 350 53 00 phone

Asia-Pacific Headquarters

Singapore
+65 6389 6500 phone

Visit us on the Web at www.pall.com/biotech
Contact us at www.pall.com/contact

Pall Corporation has offices and plants throughout the world. To locate the Pall office or distributor nearest you, visit www.pall.com/contact.

The information provided in this literature was reviewed for accuracy at the time of publication. Product data may be subject to change without notice. For current information consult your local Pall distributor or contact Pall directly.

© Copyright 2021, Pall Corporation. Pall, , Allegro, iCELLis, Kleenpak and mPath are trademarks of Pall Corporation. Accelerator is a service mark of Pall Corporation. ® Indicates a trademark registered in the USA. ♦ Wonderware is a trademark of Schneider Electric Software; MolMed is a trademark of Molmed s.p.A. Avisis is a trademark of Novartis AG, Orgenesis is a trademark of Orgenesis Inc. Lauda is a trademark of Lauda DR. R. Wobser GMBH & Co. and Memorial Sloan-Kettering Cancer Center is a trademark of the Memorial Sloan-Kettering Cancer Center Corporation.